

THIS DRAWING IS UNPUBLISHED. RELEASED FOR PUBLICATION
 © COPYRIGHT - By - ALL RIGHTS RESERVED.

LOC	DIST	REVISIONS			
P	LTR	DESCRIPTION	DATE	DWN	APVD
H	-	A	INITIAL RELEASE	26NOV2013	GSK BvH
		A1	ECR-14-015049	13OCT2014	GSK BvH
		A2	ECR-15-012701	27AUG2015	TB BvH

NOTES:
 Tolerances cable lengths:
 0m to 0.5m +30mm
 0.5m to 1.0m +50mm
 1.0m to 3.0m +100mm
 < 3.0m +1.5%

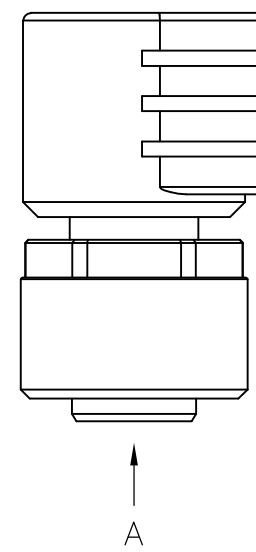
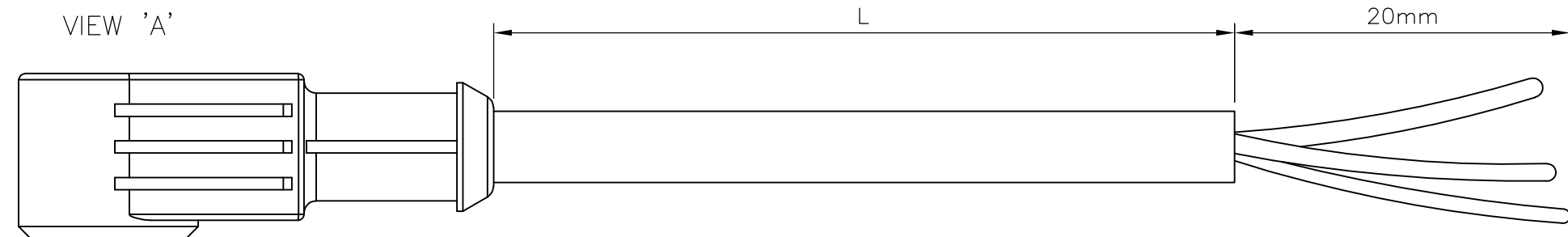
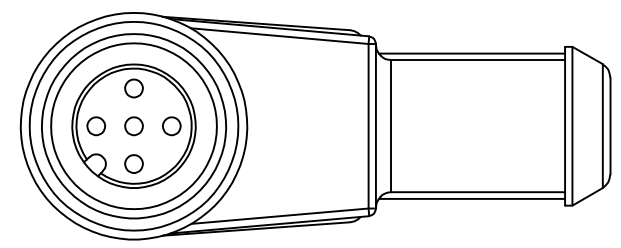

PVC CABLE	
No./diameter of wires	4 x 0.34 mm ²
Wire isolation	PVC (br, wh, bl, bk)
C-track properties	
Jacket	PVC (UL/CSA)
Outer diameter	approx. 5.0 mm
Bend radius (moving)	10 x outer diameter
Temperature range (fixed)	-30...+80 °C
Temperature range (mobile)	-5...+80 °C

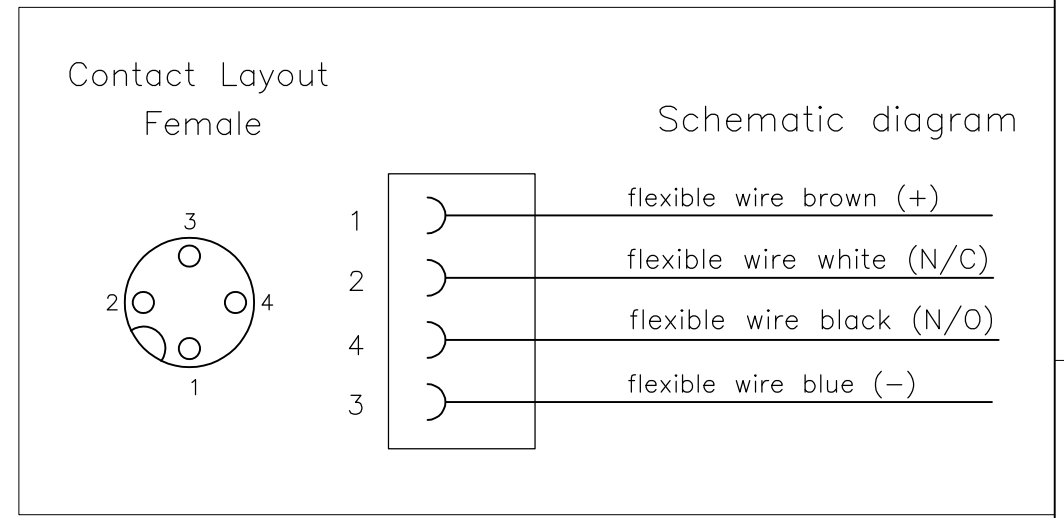

TECHNICAL DATA	
Protection	IP65 and IP67 when plugged and screwed down (EN 60529)
Operating voltage	24 V AC/DC
Operating current per contact	max. 4 A
Locking of ports	Screw thread M12 x 1 mm (recommended torque 0.6 Nm) self-securing

LENGTH "L"	MATERIAL	JACKET COLOR	TE PN	DESCRIPTION	ITEM
4 pos	PVC	Black	1-2273083-4	4x22AWG PVC 10.0m	8
			1-2273083-3	4x22AWG PVC 5.0m	7
			1-2273083-2	4x22AWG PVC 3.0m	6
			1-2273083-1	4x22AWG PVC 1.5m	5
4 pos	PUR	Black	2273083-4	4x22AWG PUR 10.0m	4
			2273083-3	4x22AWG PUR 5.0m	3
			2273083-2	4x22AWG PUR 3.0m	2
			2273083-1	4x22AWG PUR 1.5m	1

PUR CABLE	
No./diameter of wires	4 x 0.34 mm ²
Wire isolation	PVC (br, wh, bl, bk)
C-track properties	
Jacket	PUR/PVC (UL/CSA)
Outer diameter	approx. 5.9 mm
Bend radius (moving)	15 x outer diameter
Temperature range (fixed)	-30...+80 °C
Temperature range (mobile)	-5...+70 °C

THIS DRAWING IS A CONTROLLED DOCUMENT.

DIMENSIONS: mm	TOLERANCES UNLESS OTHERWISE SPECIFIED:	DWN SATHISH KUMAR .G 26NOV2013	TE Connectivity M12 X 1.0 ANGLED SOCKET PIGT A
	0 PLC ± -	CHK B.VELDHOVEN 26NOV2013	
	1 PLC ± -	APVD A.VAN ZANDVOORT 26NOV2013	
	2 PLC ± -	NAME	
	3 PLC ± -	PRODUCT SPEC 108-19483	
	4 PLC ± -	APPLICATION SPEC 114-32127	SIZE CAGE CODE DRAWING NO RESTRICTED TO
	ANGLES ± -	WEIGHT -	A3 00779 C-2273083
MATERIAL -	FINISH -	CUSTOMER DRAWING SCALE NTS SHEET 1 OF 1 REV A2	