

REFERENCE SPECIFICATIONS

- DIN-41612
- IEC-603-2

PHYSICAL CHARACTERISTICS

- **INSULATOR MATERIAL:**
- Polyester thermoplastic UL94V0 - Color grey
- **CONTACT MATERIAL:** -PHOSPHOR BRONZE : (FEMALE CONTACT)
-PHOSPHOR BRONZE : (MALE CONTACT-SOLDER TAILS)

ELECTRICAL CHARACTERISTICS

- **CURRENT RATING :** 1.5A at 20°C / 1A at 70°C 40A AT 20°C (power contact)
- **MAXIMAL CURRENT:** 2A
- **CONTACT RESISTANCE** ≤20mΩ ≤1mA under 10 A (power contact)
- **VOLTAGE PROOF:** contact/contact 1000 V eff (0.5 mA / 50 Hz)
contact/ground 1550 V eff (0.5 mA / 50 Hz)
- **INSULATION RESISTANCE:** >10⁶ MΩ
- **CREEPAGE AND CLEARANCE DISTANCE:** >1.2 mm
- **WIPPING/PLUG IN DIRECTION:** >1.8mm
- **ALTERNATIF CURRENT V AC:** 330 V
- **DIRECT CURRENT V DC:** 470 V

MECHANICAL CHARACTERISTICS

- **MATING FORCE :** ≤ n x 0.94 N (n = NUMBER OF CTS) ≤ 10 N (power contact)
- **UNMATING FORCE :** ≥ n x 0.15 N (n = NUMBER OF CTS) ≤ 10 N (power contact)
- **GAUGE RETENTION FORCE:** ≥0.15 N
THICKNESS GAUGE = 0.56 0/-0.02 - SURFACE ROUGHNESS: Ra = 0.25µm MAX1
- **CONTACT RETENTION IN INSULATOR:** ≥ 20 N according to IEC 512 test 6d
- **VIBRATIONS:** ≤ 1 µs according to IEC 512.4 test 6d
≤ 40 ma according to DIN41640 teil 15 test 6d

DIN class 3	(not applicable)
DIN class 2	10-500 HZ/5g
DIN class 1	10-2000 HZ/20g

- **SHOCK:** ≤ 1 µs according to IEC 512 test 6c
≤ 40 ma according to DIN 41640 teil 14 test 6c

ENVIRONMENTAL CHARACTERISTICS

- **CLIMATIC CATEGORY:** TEMPERATURE RANGE -55°C TO +125°C
DAMP HEAT STEADY STATE 56 DAYS Class 1
21 DAYS Class 2
(not applicable) Class 3
- **ELECTRICAL LOAD AND TEMPERATURE:** T= +70°C / I= 1A PER CTS - 1000 HRS

PERFORMANCE LEVELS TIN LEAD P/N : 8609 XXX XX XX 7XX XXX EX

Pure Tin P/N : 8609 XXX XX XX 7XX XX LF

MECHANICAL ENDURANCE AND INDUSTRIAL ATMOSPHERE TEST ⁽¹⁾		
		PERFORMANCE LEVELS
4	50 OPERATIONS	DIN Class 3
5	200 OP. + TEST(1) 4 DAYS + 200 OP.	DIN Class 2
6	250 OP. + TEST(1) 21 DAYS + 250 OP.	DIN Class 1

TEST ⁽¹⁾ INDUSTRIAL ATMOSPHERE SO₂

METALLIZED HOLE DIMENSIONS

- P.C.B HOLE DEFINITION: FINISH HOLE: Ø 0.90 - 1.10

CONTACT PLATING

- **TIN LEAD VERSION:**
MALE AND FEMALE CONTACTS:
- GOLD OVER NICKEL or GOLD+PALLADIUM-NICKEL OVER NICKEL ON MATING SURFACES
- TIN LEAD OVER NICKEL ON SOLDER TERMINATION
- **LEAD FREE VERSION:**

NOTE RoHS INFORMATION

- The "LF" products meet European Union Directives and other country regulations as described in GS-22-008.
- The housing will withstand exposure to 260°C peak temperature for 3.5 seconds in a wave solder application with a 1.6mm minimum thick circuit board.
- Termination plating spec: 1.27µm Nickel mini, 2.5 to 7.5µm Pure Tin (matte)
- Packaging spec: see GS-14-920

IMPORTANT:

- For the right angled versions , like the current leaded versions, it's recommended to use high temperature adhesive or metallic device, to protect the nearest plastic part in contact with of the solder wave, to avoid any visual plastic deterioration.

European Views

www.fciconnect.com		surface ISO 1302 ✓	tolerance std ISO 406 ISO 1101	projection mm
TOLERANCES UNLESS OTHERWISE SPECIFIED				
Dr	GOISNARD	2005/04/07	ANGULAR	LINEAR
Eng	TARON	2005/04/07	0.X	±0.1
Chr	LEGARE	2005/04/07	0.XX	±0.1
Appr	LEGARE	2005/04/07	0.XXX	±0.1
Product family			DIN 8609	Spec ref -
title DIN 41612 STB CONNECTORS				Rev. F
catalog no				dwg no C-8609-0000A
CUSTOMER				sheet 1 of 1

rev	ecn no	dr	date
A	LS05-0039	LGO	2005/04/07
B	LS05-0070	LGO	2005/09/13
C	LS06-0097	LGO	2006/07/11
D	LS06-0142	LGO	2006/09/18
E	LS06-0201	HLE	2006/11/29
F	LS07-0211	HLE	2007/08/16
-	-	-	-

TECHNICAL SPECIFICATION

HOUSING MATERIAL : THERMOPLASTIC POLYESTER UL 94 V-0, GREY
 HOUSING CAN WITHSTAND EXPOSURE TO LEAD FREE WAVE SOLDERING TEMPERATURE OF 260-265°C FOR STRAIGHT CONNECTORS AS IT IS IN CLASSICAL LEAD WAVE SOLDERING AT 235-250°C

CONTACT MATERIAL : COPPER ALLOY

CONTACT PLATING

ACTIVE ZONE : GOLD OVER NICKEL

TERMINATION ZONE

LEAD FREE VERSION : TIN (PURE MATTE) OVER Ni

ELECTRICAL DATA

CURRENT RATING AT 20°C : 1.5 A
 CURRENT (I MAX) : 2 A
 TEMPERATURE RANGE : -55°C/ +125°C
 CONTACT RESISTANCE : ≤ 20mΩ
 INSULATION RESISTANCE : ≥ 10⁶ MΩ
 TEST VOLTAGE (rms) : 1000V

MECHANICAL DATA

INSERTION FORCE PER CONTACT : ≤ 0.94N
 EXTRACTION FORCE PER CONTACT : ≥ 0.15N

REFERENCE SPECIFICATIONS : DIN 41612 / IEC 603-2

SERIES	8609	2	64	6	1	24	7	5	5	V1LF
ROWS FITTED WITH CONTACTS										
Rows a b -		2	64							
Rows a -		1	32							
NUMBER OF CONTACTS										
TYPE OF INSULATOR										
2 ROW FEMALE INSULATOR				6						
METHOD OF MOUNTING										
STANDARD MOUNTING - STYLE B					1					
TERMINATION										
LONG STRAIGHT SPILL (L - SEE TABLE)									14	
SHORT STRAIGHT SPILL (L - SEE TABLE)									24	
OPTIONS										
NO OPTION									7	
WITH HARPOONS									H	
PERFORMANCE CLASS										
4 - DIN 41612 CLASS 3										4
5 - DIN 41612 CLASS 2										5
6 - DIN 41612 CLASS 1										6
8 - AS PER MIL C 55302/JSS 50808										8
PITCH PER ROW										
2.54										5
V1LF										LEAD FREE VERSION

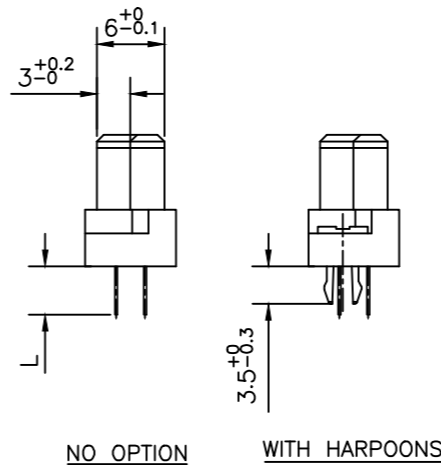
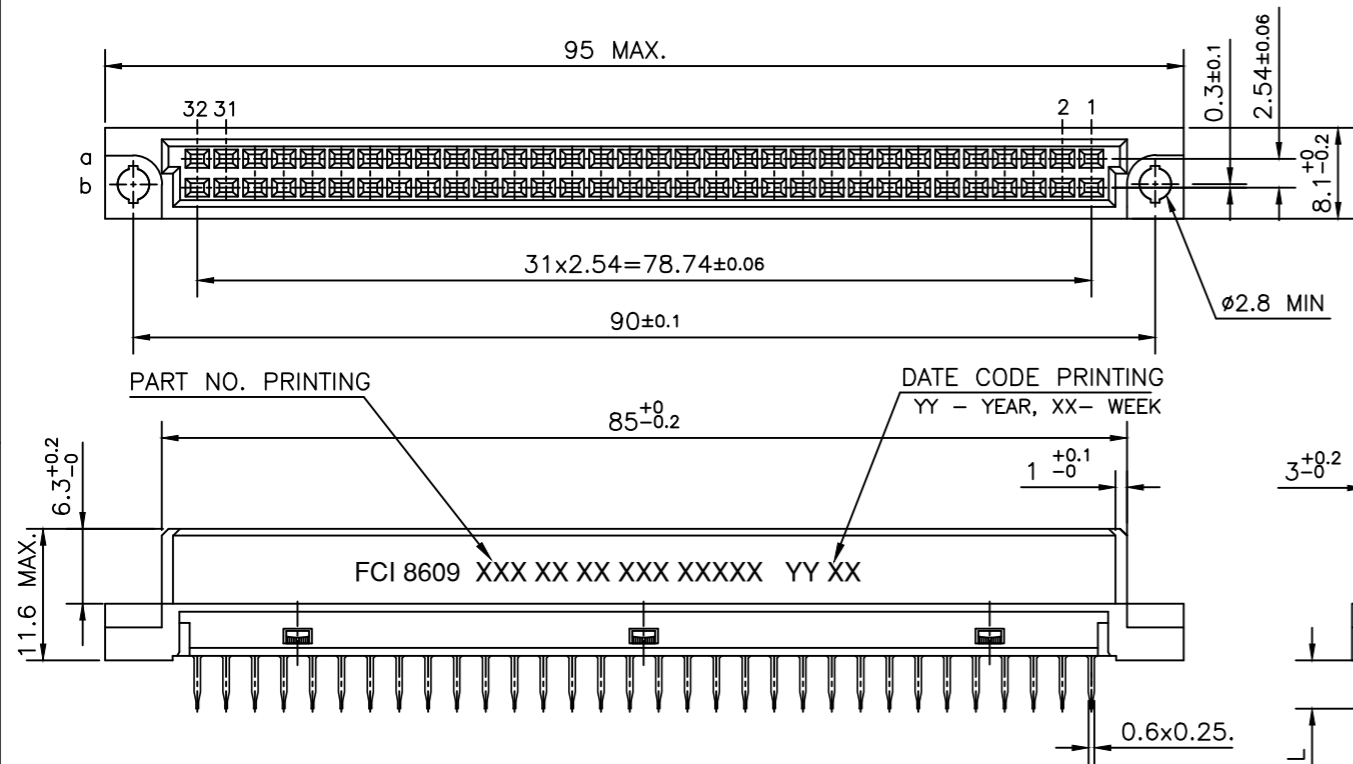

P.C.B DRILLING DETAILS

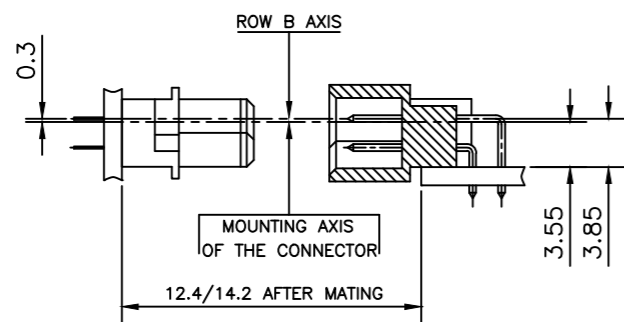
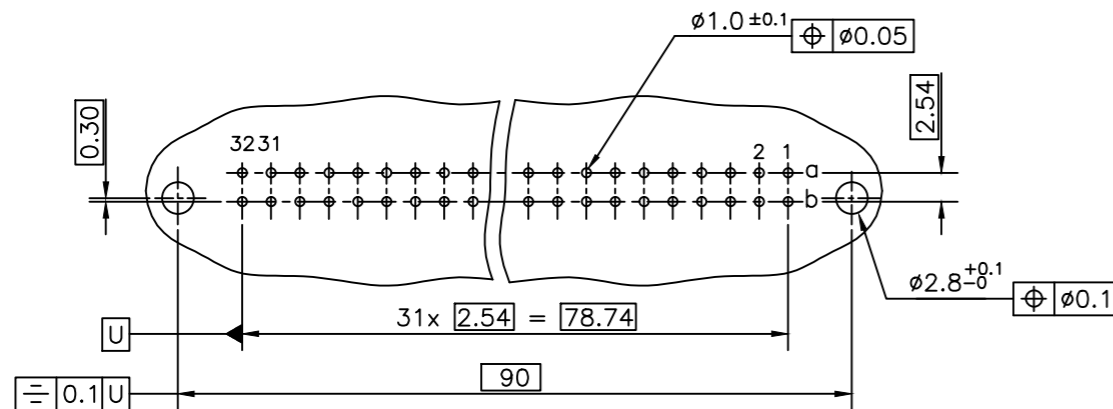

24	2.5
14	4.0
TERM. STYLE	L +0.7

NOTES:-

1. THE "LF" PRODUCTS MEET EUROPEAN UNION DIRECTIVES AND OTHER COUNTRY REGULATIONS AS DESCRIBED IN GS-22-008
2. THE HOUSING WILL WITHSTAND EXPOSURE TO 260°C PEAK TEMPERATURE FOR 3.5 SECONDS IN A WAVE SOLDER APPLICATION WITH A 1.6 MM MINIMUM THICK CIRCUIT BOARD
3. LEAD FREE OR RoHS DIRECTIVE LABELING TO BE PROVIDED AS PER GS-14-920 FOR LEAD FREE VERSION.

mat'l. code		surface		tolerance		projection		product family	
-		ISO 1302 ✓		ISO 406 ISO 1101		mm		8609	
ltr		ecn no		dr		date		title	
A		-		MJA		2012-10-10		DIN STANDARD RECEPTACLE	
-		-		-		-		STRAIGHT SPILL DIN 41612 STYLE-B	
-		-		-		-		dwg no	
-		-		-		-		sheet 1 of 1	
-		-		-		-		size	
-		-		-		-		A3	
-		-		-		-		type	
-		-		-		-		Product Customer Drawing	
sheet index		revision sheet		A		1			



Copyright FCI