

PRODUCT NUMBER  
71991-YXXXLF

- RoHS COMPATIBLE, SEE NOTE 6.
- OPTIONAL LETTER
- H: HIGH TEMPERATURE PRODUCT.
- NUMBER OF POSITIONS PER ROW: 02 TO 50.
- PLATING CODE
- 3= 0.76µm GOLD ON CONTACT AREA.  
2µm MIN MATTE TIN ON TAIL.
- 4= 2µm MIN MATTE TIN FULL PLATED
- 8= 0.38µm GOLD ON CONTACT AREA.  
2µm MIN MATTE TIN ON TAIL.
- 1.27µm Ni MIN UNDERPLATING

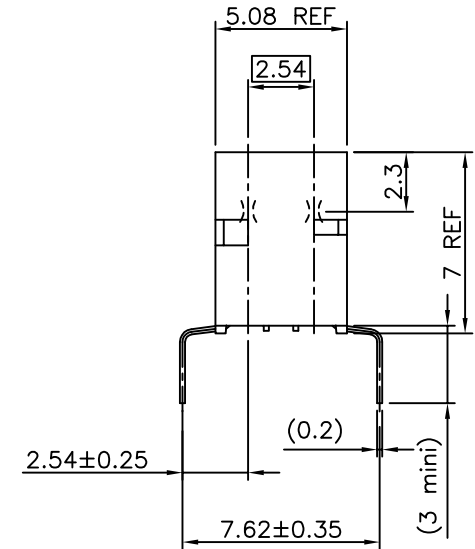
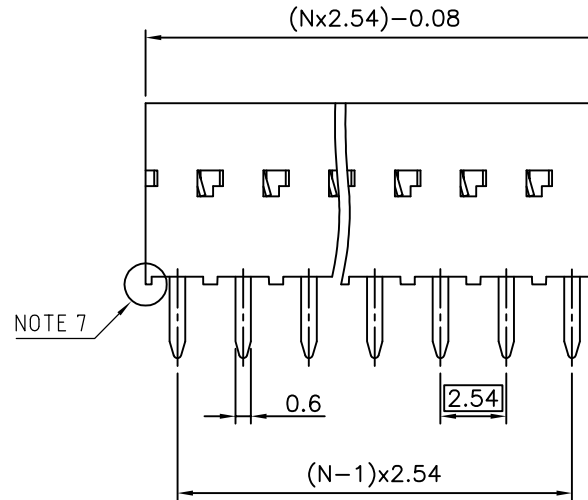
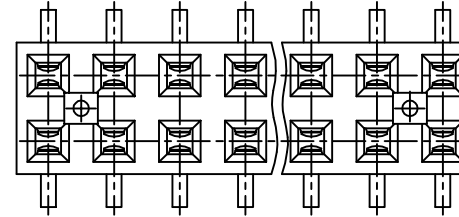

NOTES:

- 1 - HOUSING MAT'L: THERMOPLASTIC GLASS FILLED FLAME RETARDANT PER UL 94 V-0  
LOW TEMPERATURE: COLOR BLUE  
HIGH TEMPERATURE: COLOR GREY.
- 2 - TERMINAL MATERIAL: PHOSPHOR BRONZE.
- 3 - 2 UP TO 50 POSITIONS PRODUCT PACKED IN TUBE.
- 4 - TO DETERMINE DIMENSIONS:  
N = NUMBER OF POSITIONS PER ROW  
EXAMPLE: 8 POS: (N x 2.54) - 0.08 = 20.24 mm
- 5 - RECOMMENDED IR PROFIL PER TA 842.
- 6 - RoHS COMPATIBLE PRODUCT SPECIFICATIONS

a - PLATING:

- "LF" MEANS THE PRODUCT IS LEAD-FREE, 2µm MINIMUM MATTE TIN OVER 1.27µm MINIMUM NICKEL UNDERPLATE.

b - MANUFACTURING PROCESS COMPATIBILITY

- THE HOUSING WILL WITHSTAND EXPOSURE TO 260°C ± 5°C SOLDER BATH TEMPERATURE FOR 5 SECONDS IN A WAVE SOLDER APPLICATION WITH A 1.6mm MIN THICK CIRCUIT BOARD.

c - LABELING:

- MEETS PACKAGING SPECS AS PER GS-14-920

d - LEGAL STATEMENT: SEE GS-47-0004

- 7 - END STAND-OFFS FOR 2x2 UP TO 2x5 POS  
NO END STAND-OFFS FOR 2x6 UP TO 2x50 POS

mat'l. code SEE NOTES				surface ISO 1302 <input checked="" type="checkbox"/> ISO 406 <input type="checkbox"/> ISO 1101 <input type="checkbox"/>		tolerance ISO 406 <input checked="" type="checkbox"/> ISO 1101 <input type="checkbox"/>		projection 		product family DUBOX	
ltr	ecn no	dr	date	tolerances unless otherwise specified		±0.3		mm		title BtB RECEPT. VERT DR TMT	
Y	B-19123	LMU	14.10.20	angles	linear			scale 5:1		dwg no 71991	
T	F06-0137	DLE	06.02.27	±2'						sheet 1 of 2 size A3	
U	F06-0204	DLE	06.06.20	dr	D LEGRAND	04.09.27			type CUSTOMER Drawing		
V	F06-0323	DLE	06.11.21	engr	P NIZZI	04.09.27					
W	F09-0011	LMU	09.02.16	chr	D LEGRAND	04.09.27					
X	F11-0043	JCO	12.02.22	appd	P NZ	04.09.27					
sheet	revision		Y	B							
index	sheet		1	2							

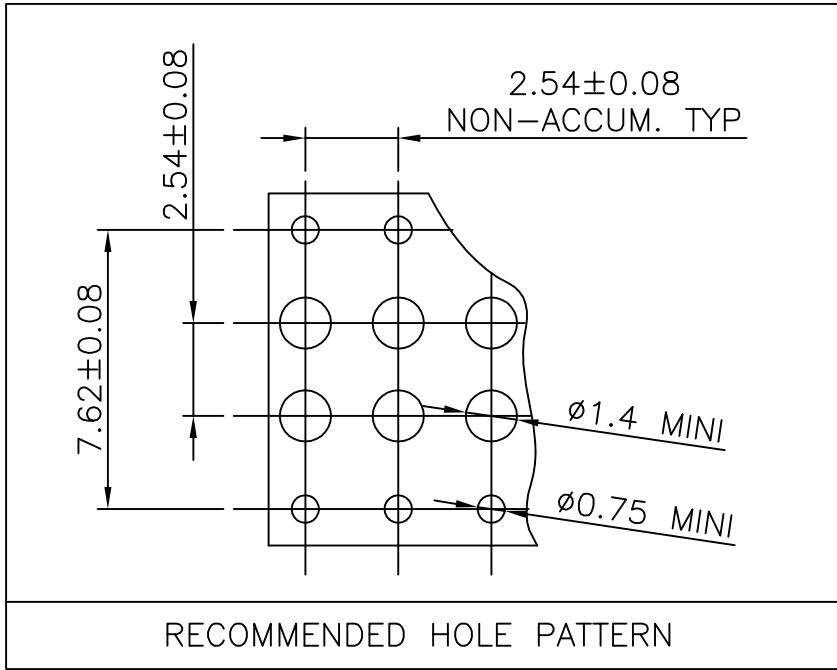

FCI  
FCIconnect.com

mat'l. code SEE SHEET 1				surface ISO 1302 ✓		tolerance ISO 406 ISO 1101		projection 		product family DUBOX			
ltr	ecn no	dr	date	tolerances unless otherwise specified		angles		mm 		title BtB RECEPT. VERT DR TMT			
A	F04-0347	DLE	04.09.27	linear		±0.3		scale 5:1					
B	F06-0204	DLE	06.06.20	±2'						dwg no		sheet 2 of 2	size
				dr	D LEGRAND	04.09.27			71991		A4		
				enr	P NIZZI	04.09.27							
				chr	D LE	04.09.27							
				appd	P NZ	04.09.27							
sheet index		revision sheet							type		CUSTOMER Drawing		