

PRODUCT NUMBER

76341-YXXXLF

- RoHS COMPATIBLE, SEE NOTE 5.
- OPTIONAL LETTER  
H: HIGH TEMPERATURE PRODUCT.
- NUMBER OF POSITIONS: 02 TO 50.
- PLATING CODE  
3= 0.76µm GOLD ON CONTACT AREA.  
2µm MIN MATTE TIN ON TAIL.  
4= 2µm MIN MATTE TIN FULL PLATED  
1.27µm Ni MIN UNDERPLATING

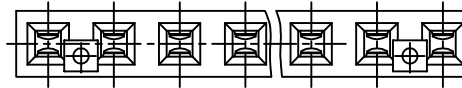

NOTES:

- 1 - HOUSING MAT'L: THERMOPLASTIC GLASS FILLED FLAME RETARDANT PER UL 94 V-0  
LOW TEMPERATURE: COLOR BLUE  
HIGH TEMPERATURE: COLOR GREY.
- 2 - TERMINAL MATERIAL: PHOSPHOR BRONZE.
- 3 - 2 UP TO 4 POSITIONS PRODUCT PACKED IN PLASTIC BOX.  
5 UP TO 50 POSITIONS PRODUCT PACKED IN TUBE.
- 4 - TO DETERMINE DIMENSIONS:  
N = NUMBER OF POSITIONS  
EXAMPLE: 8 POS: (N x 2.54) - 0.08 = 20.24 mm
- 5 - RoHS COMPATIBLE PRODUCT SPECIFICATIONS
  - a - PLATING:
    - "LF" MEANS THE PRODUCT IS LEAD-FREE, 2µm MINIMUM MATTE TIN OVER 1.27µm MINIMUM NICKEL UNDERPLATE.
  - b - MANUFACTURING PROCESS COMPATIBILITY
    - THE HOUSING WILL WITHSTAND EXPOSURE TO 260°C ±5°C SOLDER BATH TEMPERATURE FOR 5 SECONDS IN A WAVE SOLDER APPLICATION WITH A 1.6mm MIN THICK CIRCUIT BOARD.
  - c - LABELING:
    - MEETS PACKAGING SPECS AS PER GS-14-920
  - d - LEGAL STATEMENT: SEE GS-47-0004
- 6 - END STAND-OFFS FOR 1x2 UP TO 1x5 POS  
NO END STAND-OFFS FOR 1x6 UP TO 1x50 POS

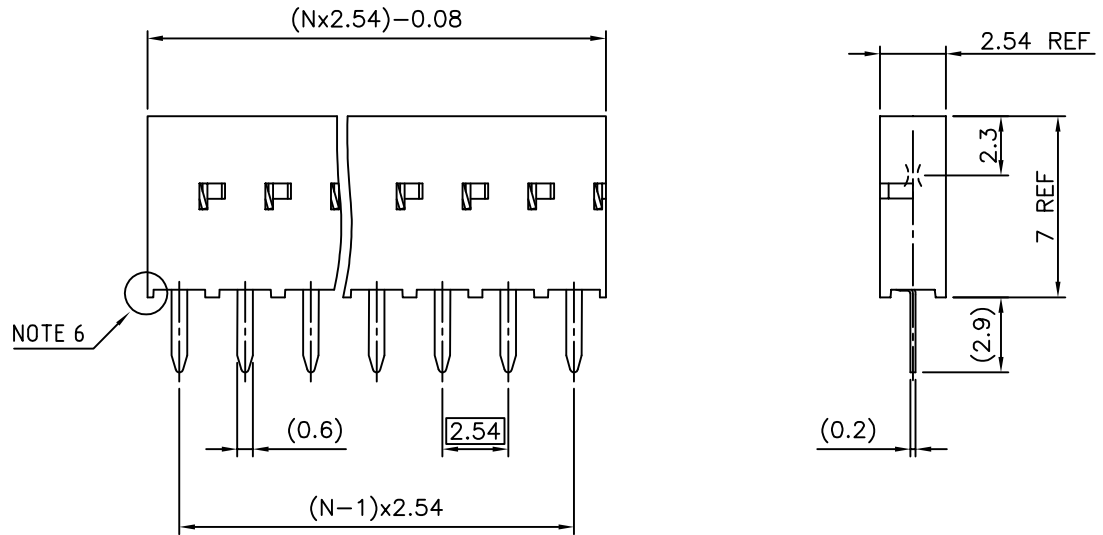

NOTE 6

mat'l. code SEE NOTES				surface ISO 1302 ✓		tolerance ISO 406 ISO 1101		projection mm		product family DUBOX			
P	F11-0043	JCO	12.02.22	tolerances unless otherwise specified		±0.3		mm		title BtB RECEPT. VERT SR TMT			
R	B-19123	LMU	14.10.21	angles	linear			scale 5:1		sheet 1 of 2 size A3			
K	F10110	GCO	01.01.16	dr	D LEGRAND	04.09.27				dwg no 76341			
L	F03-0284	DLE	03.10.07	enrg	P NIZZI	04.09.27				type CUSTOMER		Drawing	
M	F04-0347	DLE	04.09.27	chr	D LEGRAND	04.09.27							
N	F06-0204	DLE	06.06.20	appd	P NZ	04.09.27							
sheet index	revision	R	B										
	sheet	1	2										

A

A

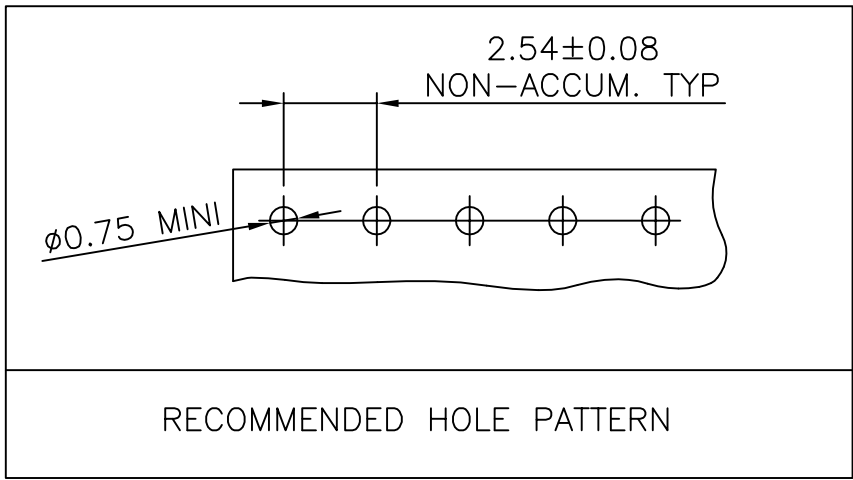

B

B

C

C



mat'l. code SEE SHEET 1				surface ISO 1302 <input checked="" type="checkbox"/>		tolerance ISO 406 ISO 1101		projection 		product family DUBOX			
ltr	ecn no	dr	date	tolerances unless otherwise specified		angles		mm 		title BtB RECEPT. VERT SR TMT			
A	F04-0347	DLE	04.09.27	linear	±0.3	±2'	scale 5:1		dwg no 76341		sheet 2 of 2		size A4
B	F06-0204	DLE	06.06.20								type CUSTOMER		Drawing
sheet index		revision sheet											

Copyright FCI

D

D