



# Instruction Manual

# Lama

*RTF*

Art.-Nr.: 25168



Amewi Trade e.K.  
Nikolaus-Otto-Str. 18  
33178 D-Borchen  
amewi.com

## Declaration of Conformity

This product has been manufactured according to actual technical standards. The product is matching the requirements of the existing European and national guidelines. The Declaration of Conformity has been proofed. AMEWI Trade e.K. declares that this product is matching the basic requirements and remaining regulations of the guideline 2014/53/EU (RED). The declarations and documents are stored at the manufacturer and can be requested and applied there.

The full text of the declaration of conformity can be found at: <https://amewi.com/Konformitaetserklaerungen>

For additional questions to the product and conformity please contact:  
AMEWI Trade e.K. Nikolaus-Otto-Str. 18, 33178 Borcheln or via the website [amewi.com](https://amewi.com)



## Security and Hazard Warnings



**Attention!** For damage, caused by disregarding of the manual, warranty expires !

We are not liable for secondary failures, material or personal damage, caused by improper usage or disregarding the security notices.

**Attention!** Based on security and registration (CE) reasons, it is forbidden to modify the product personally. Do not disassemble the product.

**Attention!** Small parts. Danger of suffocation or risk of injury caused by small parts.

**Attention!** Suitable for people aged 14+ !



The product is not allowed to get moist or wet. The product is only allowed to be used on flat and clean surfaces. Even a drop down from a small height can cause damage to the product. Usage of more than one Products of same Frequency at the same time is not possible, because it will affect each other.

## Battery Notice and Battery Disposal



**Attention!** Battery do not belong in childrens hands. A change of the battery has to be done by an adult person. Never mix chargable batteries with non-chargeable batteries. Never mix fully charged batteries with almost empty batteries. Never mix batteries of different capacities. Never try to charge dry batteries. Take care of the correct polarity. Defective batteries belong to special waste. Never leave a charging battery unattended. For questions about the charging time please read the manual or ask the manufacturer.

## Disposal



The company AMEWI is registered below the WEEE Reg. Nr. DE93834722 at the foundation EAR and recycles all used electronic parts properly. Electric and electronical products are not allowed to put in household garbage. Please dispose the product at the end of the lifetime according to the actual laws. You as a customer are responsible by law for the return of all used batteries, a disposal over the household garbage is forbidden !

Batteries containing hazardous substances are marked with the alongside symbols, which point to the prohibition of disposal in household garbage.

Additional notations for the critical heavy metal are: Cd=Cadmium, Hg=Quecksilver, Pb=lead (Label is placed on the batteries, for example below the bottom left trash symbols).









Based on RoHS labeling the manufacturer confirms, that all limit values were taken care of at the time of manufacturing.

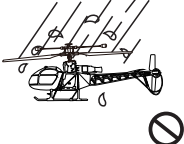

Batteries labeled with the recycling symbol can be put into used battery collecting tank. (Most supermarkets have)  
They are not allowed to be put into local household garbage.



AMEWI Trade e.K. is involved in the dual system for boxing over the company Firma Landbell AG. All used boxes are collected from partner companies (waste disposal contractor) at private customers (local household), sorted and properly utilized. The Involvement in a Dual Systems helps to save CO<sup>2</sup> Emissions.

<p><b>FORBIDDEN</b> <b>PREVENT MOISTURE</b></p> <p>R/C models are composed of many precision electrical components. It is critical to keep the model and associated equipment away from moisture and other contaminants. The introduction or exposure to water or moisture in any form can cause the model to malfunction resulting in malfunction, or a crash. Do not operate or expose to rain or moisture.</p>	
<p><b>FORBIDDEN</b> <b>PROPER OPERATION</b></p> <p>To avoid potential fire hazard from batteries, please do not short, reverse polarity, or puncture batteries. Battery charging must be done under supervision at all times, and at location out of reach by children. Double check the four AA batteries are rechargeable Ni-CD/MH batteries before charging. The manufacturer or this product will not be liable for accidental damages incurred by charging non-rechargeable batteries.</p>	
<p><b>FORBIDDEN</b> <b>SAFETY NOTE FOR NI-MH BATTERIES</b></p> <p>Make sure the batteries are installed based on polarity indicated in the case and do not mix batteries of different chemistry/spec. Please take out the batteries if you are not going to use for a long time to avoid potential leakage which may damage the transmitter. Please dispose depleted batteries according to local laws and ordinances. Do not dispose improperly.</p>	
<p><b>FORBIDDEN</b> <b>SAFETY NOTE ON LI-POLYMER BATTERIES</b></p> <p>Li Polymer batteries poses higher operational risks compared to other battery chemistry, thus it is imperative to follow its usage instructions. Manufacturer and dealer assume no liability for accidental damages caused by improper usage. Do not use charger other than the factory supplied unit to avoid potential fire and explosion. Do not crush, disassemble, burn, and reverse polarity. Avoid metallic materials to come into contact with battery's polarity and cause it short and never puncture batteries to avoid fire hazards. Battery charging must be done under supervision at all times, and at location out of reach by children. Please stop the use or charge of the battery should there be an unusual increase in battery temperature after use. Continue use of this battery may cause it to expand, deform, explode, or even result in fire hazards. Please dispose depleted batteries according to local laws and ordinances. Do not dispose improperly.</p>	
<p><b>CAUTION</b> <b>KEEP AWAY FROM HEAT</b></p> <p>R/C models are made of various forms or plastic. Plastic is very susceptible to damage or deformation due to extreme heat and cold climate. Make sure not to store the model near any source of heat such as an oven, or heater. It is best to store the model indoors, in a climate-controlled, room temperature environment.</p>	
<p><b>WARNING</b> <b>OBTAIN THE ASSISTANCE OF AN EXPERIENCED PILOT</b></p> <p>The products are suitable for more than 15 years old, at the beginning it will have some certain difficulty in learning, suggestion guidance by experienced when playing.</p>	

### 3.PACKAGE ILLUSTRATION

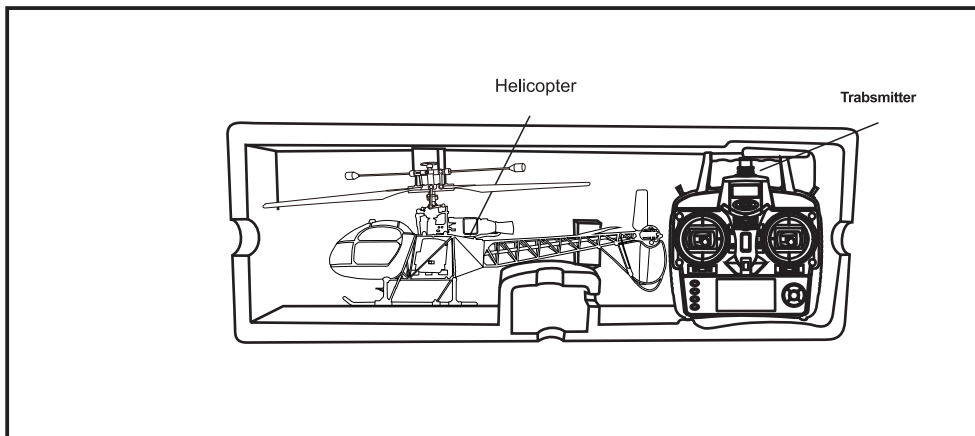

### 4.TRANSMITTER BATTERY INSTALLATION

**Step 1**

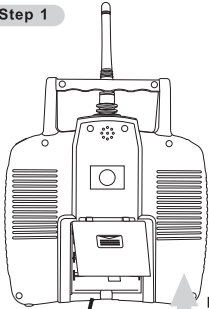

Push

Slide the battery lid to open by following the arrow.

**FORBIDDEN**

**Do not disassemble**

**Step 2**

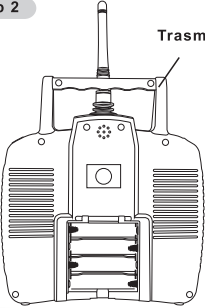

Trasmitter

Please use 4 AA sized batteries, installed based on polarity indicated case. Do not mix batteries of different chemistry/spec.

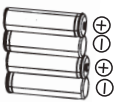



# 5 NOMENCLATURE

## Mode2

FORBIDDEN

Do not disassemble

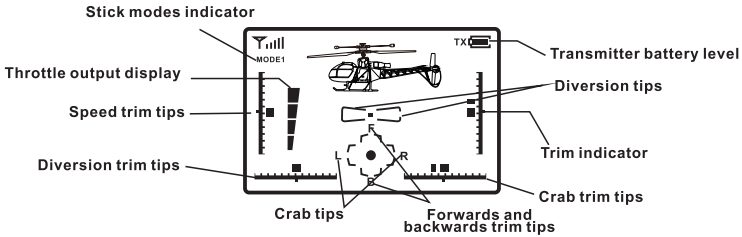
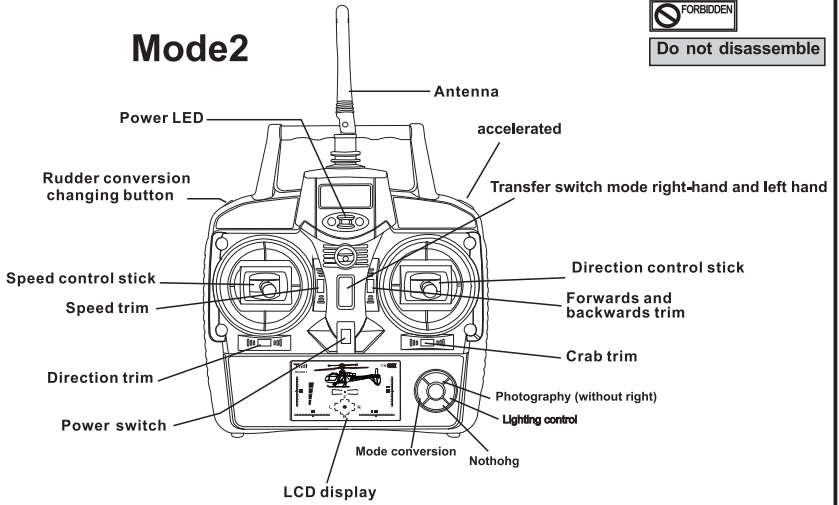

1 This remote control has four modes, you can not open the case of the remote control to achieve four kinds of mode conversion. Mode conversion right hand: the right hand switch mode when playing left-handed throttle up. When the mode switch left and right time for the right hand when playing down the throttle. Note! Convert to convert the shutdown only when the aircraft hit avoid accidents!

2. Mode exchange, hold on the switch button, and turn on the power switch at the same time, you can exchange from mode 1 to mode 3, or mode 2 to mode 4.

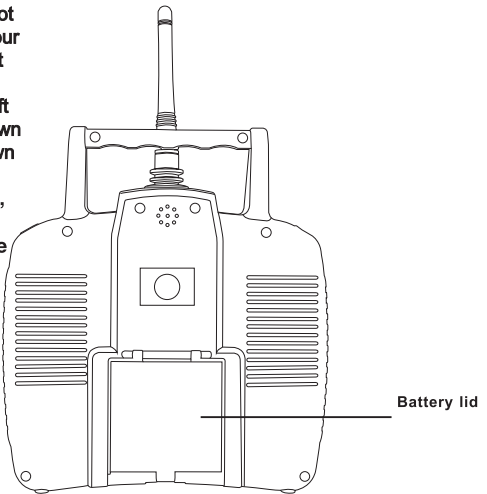

## Throttle on right hand

### Mode 1

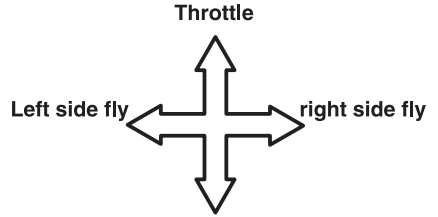
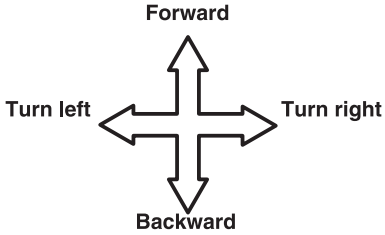

### Mode 3

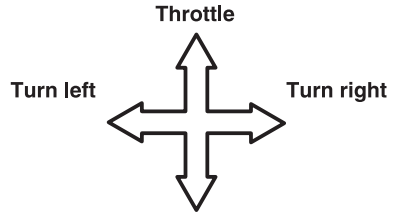
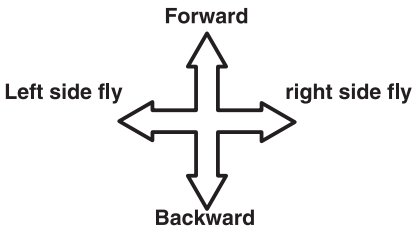

## Throttle on left hand

### Mode 2

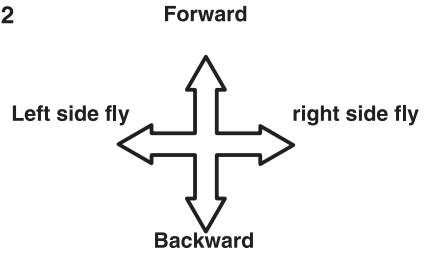
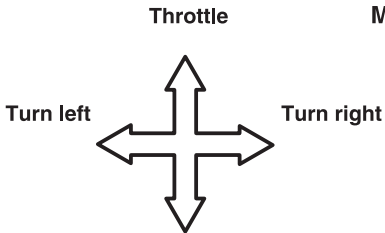

### Mode 4

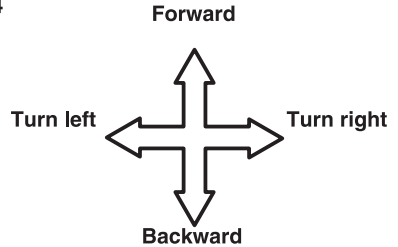
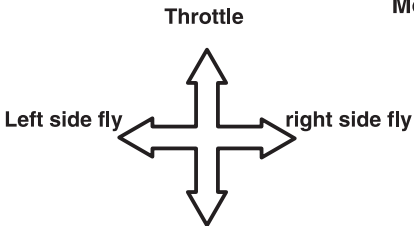

## 6. STANDARD EQUIPMENT

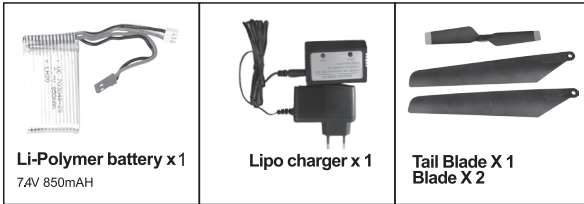

## 7. BATTERY AND CHARGER SPECIFICATION

Battery usage and charge duration reference				
Battery type	Battery Specification	Usage Duration		Charge Time
Li-po battery	7.4、850mAh	Helicopter flight time	Approx. 7-8Minutes	500 ma. About 60 minutes
Carbon-Zinc (Non Rechargeable)	1.5V (GP 15G R6P)	Transmitter Operation Time	18 Hours	Non Rechargeable



You needn't to change anything because it has been adjusted when it finish produce

## 8. BINDING OF RADIO TRANSMITTER AND RECEIVER

For the first time use or frequency interference and unable to frequency, must bind frequency again.

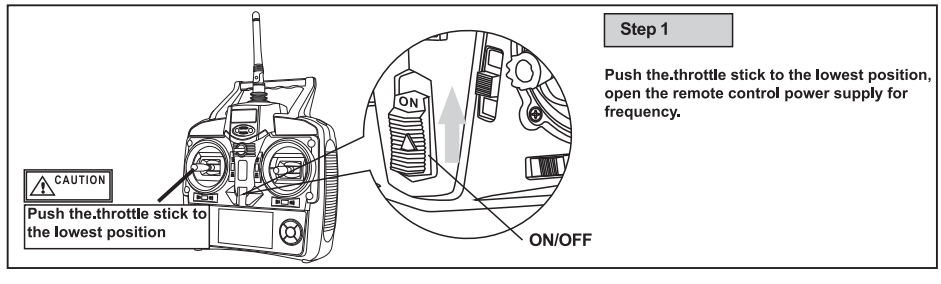

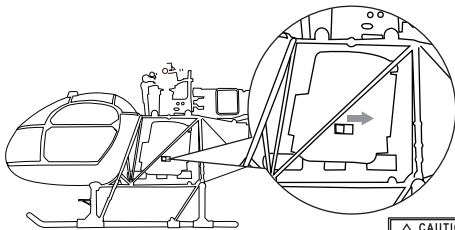

**Step 2**

A helicopter in the flat position, as shown on the power switch, the receiver on the red LED flashes, then don't move the body.



Electrode surface of batter face up.

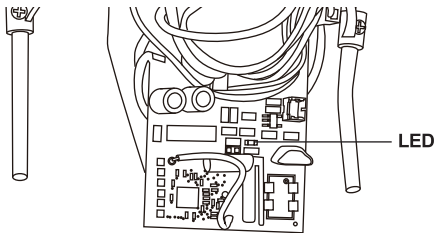

**Step 3**

The frequency of receiving plate red LED flashes, approximately 4 seconds after the LED constant light to frequency of success, if LED continues flashing expressed on the frequency of failure, must again perform steps 1 through 2 note must first open remote open plane switch on the code, so as to avoid injury.

## 9.USAGE INSTRUCTIONS AND CHECK LISTS



Check the control directions with throttle off prior to flight.

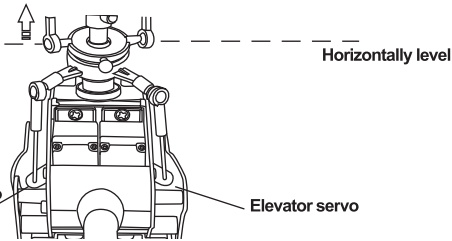

**Step 1-1**

Push right on aileron control, aileron servo will Push the left side of swashplate.

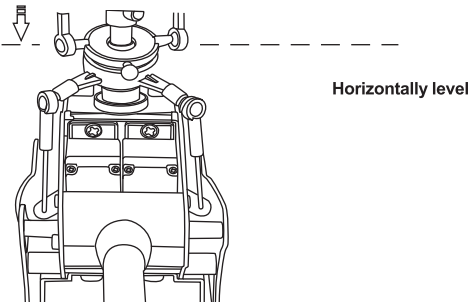
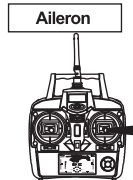

**Step 1-2**

Push left on aileron control, aileron servo will Push the left side of swashplate.

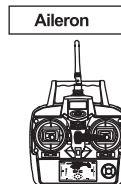

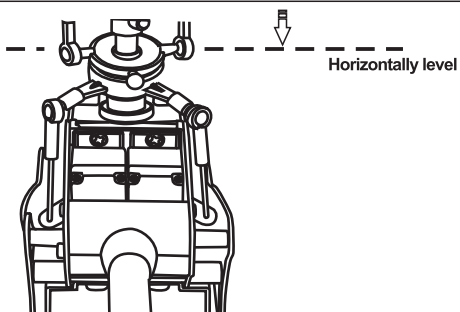

**Step 1-3**

Push up on elevator control, elevator servo will push the right side of swashplate down.

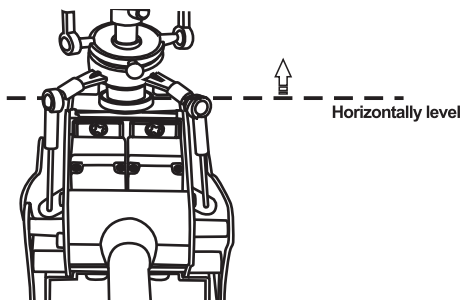
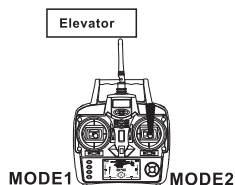

**Step1-4**

Push down on elevator control, elevator servo will push the right side of swashplate up.

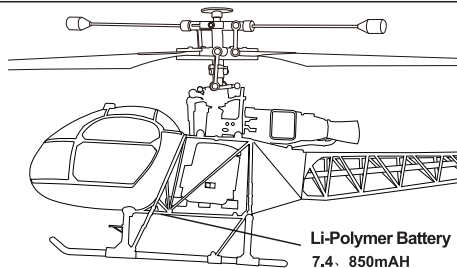
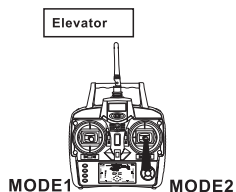

**Step 2**

The end of the flight, please switch off the helicopter timely. To develop good habits, so as to avoid regret.



Switch is not turned off, will cause excessive battery discharge and damage, and the danger of burning fire.

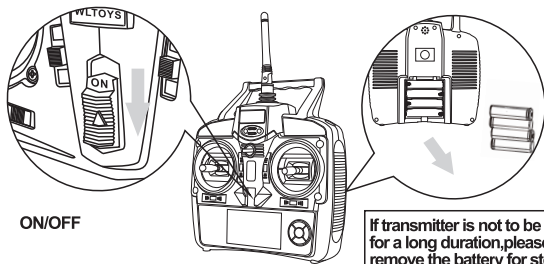

**Step 3**

Turn off the transmitter. If transmitter is not to be used for a long duration, please remove the battery for storage.



Warning: If the AA batteries are left in the transmitter, potential leakage could occur which may damage the transmitter, and create fire hazards.

# 10. FLIGHT ADJUSTMENT AND SETTING

## PLEASE PRACTICE SIMULATION FLIGHT BEFORE ACTUAL FLYING

Before you are familiar with the helicopter, please don't set it fly, read the instruction carefully. Get familiar with all kinds of direction control and keep repeating until you can play it as you perform your wishes

1. Place the helicopter in a clear open field and the tail of helicopter point to yourself.
2. Practice to operate the throttle stick (as below illustration) and repeat practicing "Throttle high/low", "Aileron left/right", "Rudder left/right", and "Elevator up/down".
3. The simulation flight practice is very important, please keep practicing until the fingers move naturally when you hear operation orders being call out.



Mode	Illustration	Mode	Illustration
<b>Aileron</b>	Move left Move right	<b>Throttle</b>	Ascent Descent
<b>Elevator</b>	Fly forward Fly backward	<b>Rudder</b>	Turn left Turn right

## FLIGHT ADJUSTMENT AND NOTICE FOR BEGINNERS

### CAUTION

- ⊙ Check if the screws are firmly tightened.
- ⊙ Check if the transmitter and receivers are fully charged.

When arriving at the flying field.



### CAUTION

- ⊙ Make sure that no people or obstructions in the vicinity.
- ⊙ You must first practice hovering for flying safety. This is a basic flight action. (Hovering means keeping the helicopter in mid air in a fixed position)
- ⊙ Please stand approximately 2m diagonally behind the helicopter.



## STEP 1 THROTTLE CONTROL PRACTICE

### Mode

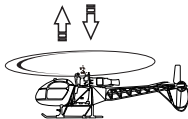

When the helicopter begins to lift-off the ground, slowly reduce the throttle to bring the helicopter back down. Keep practicing this action until you control the throttle smoothly.

## STEP 2 AILERON AND ELEVATOR CONTROL PRACTICE

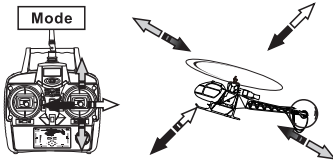

1. Raise the throttle stick slowly.
2. Move the helicopter in any direction back, forward, left and right, slowly move the aileron and elevator sticks in the opposite direction to fly back to its original position.



- ⊙ If the nose of the helicopter moves, please lower the throttle stick and land the helicopter. Then move your position diagonally behind the helicopter 2m and continue practicing.
- ⊙ If the helicopter flies too far away from you, please land the helicopter and move your position behind 2m and continue practicing.

## STEP 3 RUDDER CONTROL PRACTICING

1. Slowly raise the throttle stick.
2. Move the nose of the helicopter to right or left, and then slowly move the rudder stick in the opposite direction to fly back to its original position.

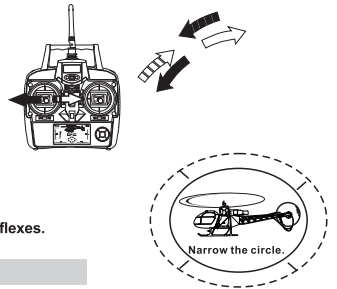

## STEP 4

After you are familiar with all actions from Step 1 to 3, draw a circle on the ground and practice within the circle to increase your accuracy.

- ⊙ You can reduce the size of the circle as you become familiar with the control reflexes.

## STEP 5 DIRECTION CHANGE AND HOVERING PRACTICE

After you are familiar with Step 1 to 4, stand at side of the helicopter and continue practicing Step 1 to 4. Then repeat the Step 1 to 4 by standing in front of the helicopter.

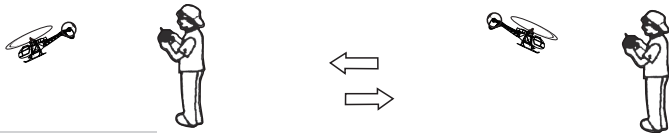

## ADJUSTMENT OF EACH TRIM

Slowly raise the throttle stick and just as the helicopter lift-off the ground, you can use the trim to correct the action if the helicopter leans in a different direction.

### 1. Adjustment of rudder trim

Just before the helicopter lift-off, the nose lean left/right...

When leans right, adjust the trim to left side.

When leans left, adjust the trim to right side.

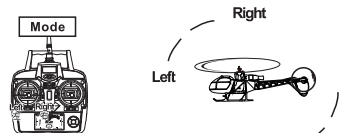

### 2. Adjustment of elevator trim

Just before the helicopter lift-off, the nose lean forward/backward...

When leans forward, adjust the trim to down.

When leans backward, adjust the trim up.

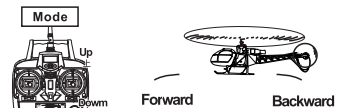

### 3. Adjustment of aileron trim

Just before the helicopter lift-off, the body lean left/right...

When leans right, adjust the trim to left side.

When leans left, adjust the trim to right side.

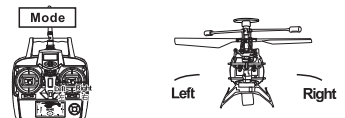

## 11 .TROUBLE SHOOTING DURING FLIGHT

	Situation	Cause	Way to deal
1	Receiver status LED blinks continuously for more than 4 seconds after helicopter battery inserted. No response to control input.	Unable to bind to transmitter.	Repeat the power up initializing process. (Refer to P.11:Binding of radio transmitter and receiver)
2	No response after battery is connected to helicopter.	1.power to transmitter and receiver. 2.Check transmitter and receiver voltage. 3.Poor contact on battery terminals.	1.Turn on transmitter and ensure helicopter battery is inserted properly. 2.Use fully charged batteries. 3.Re-seat the battery and ensure good contact between battery contacts.
3	Motor does not respond to throttle stick, receiver LED flashes.	Helicopter battery depleted.	Fully charge the battery, or replace with a fully charged battery.
4	Main rotor continue to spin after landing	Throttle trim accidentally increased during flight.	Confirm throttle trim is in center or slightly below.
5	Motor fails to run,but servo moves.	1.Throttle trim is too high, triggering safety protection function. 2.Throttle was not all the way down during power up. 3.Loose motor connection or damaged motor	1.Lower throttle trim and restart throttle. 2.Lower throttle stick all the way down and restart throttle. 3.Re-seat the motor plug or replace the motor.
6	Main rotor spins but unable to takeoff.	1.Deformed main blades. 2.Helicopter battery depleted	1.Replace main blades 2.Charge or replace with a fully charged battery.
7	Strong vibration of helicopter	1.Deformed main blades 2.Bent main shaft 3.Deformed tail rotor 4.Overtightening of main blade greps.	1.Replace main blades 2.Replace main shaft 3.Replace tail rotor 4.Re-tighten main blade grips with suitable force.
8	Tail still off trim after tab adjustment, or inconsistent speed during left/right pirouette.	1.Damaged tail rotors 2.Damaged tail drive motor 3.Helicopter was not stationary during power up. 4.Vibration induced gyro interference, causing tail unable to lock.	1.Replace tail rotors 2.Replace tail drive motor 3.Re-power the helicopter while remaining stationary. 4.Refer to symptom 7.
9	Helicopter still wonders forward after trim adjustment during hover.	1.Elevator servo not level during power up. 2.Elevator pushrod too long or too short.	1.Center elevator trim after power up, and re-install elevator servo horn at level position. 2.If helicopter drifts forward, adjust linkage longer. If it drifts backward, adjust linkage shorter.
10	Helicopter still wonders left/right after trim adjustment during hover.	1.Aileron servo not level during power up. 2.Aileron pushrod too long or too short.	1.Center aileron trim after power up, and re-install aileron servo horn at level position. 2.If helicopter drifts left, adjust linkage longer. If it drifts right, adjust linkage shorter.



	Situation	Cause	Way to deal
11	Helicopter unable to remain stationary during hover	1.Binding caused by rough components 2.Overtightening of mixing arms.	1.Confirm smooth movements of components and ball links. 2.Losen up mixing arms axial screws.
12	Unusual vibration of helicopter during flights	1.Binding between main blades and blade grips. 2.Insufficient head speed due to depletion of helicopter battery.	1.Ensure all head components are smooth with no binding. 2.Replace with a fully charged battery.

If the problem is still there even after tried above, stop flying and contact with your seller.

## 12.PARTS LIST

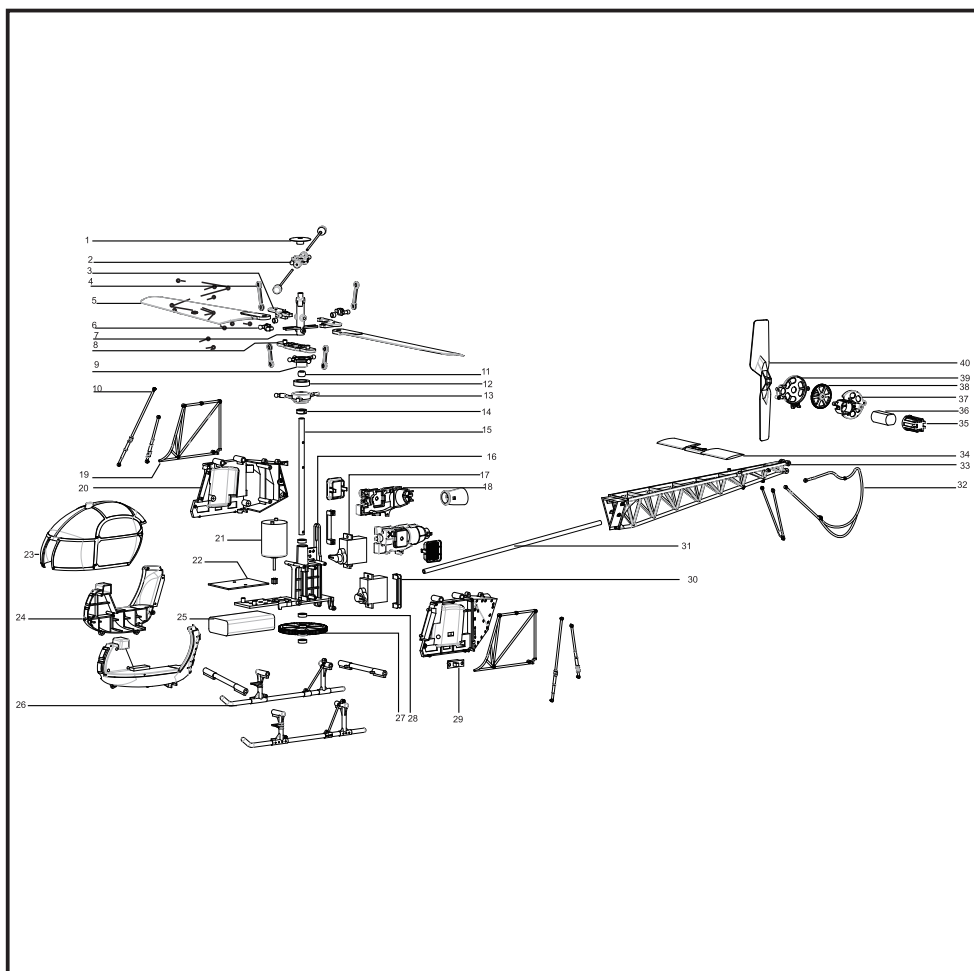

No.				
1		Decorative cover		
2		Balance rod assembly		
3		Clip on fan		
4		Connect buckle		
5		Blade		
6		Ball Accessories		
7		The central axis		
8		Under the fan clip		
9		Swash plate superstructure		
10		Garnish		
11		Fisheye copper sleeve		
12		Swash plate bearing		
13		Under the swash plate cover		
14		Fixed main pipe copper sleeve		
15		Main Pipe		
16		Mainframe		
17		Servos		
18		Engine Components		
19		Cabinet trim		
20		Cabinet		
21		The main motor		
22		Receiver board		
23		Canopy		
24		Head		
25		Lithium Battery		
26		Landing gear		
27		Main cone		
28		Bearing		
29		Switch		
30		Servo fixing accessories		
31		Transparent plastic tube		
32		Tail rod		
33		Last stand		
34		Horizontal wing		
35		Tail motor cover		
36		Tail motor		
37		Coda box cover		
38		Coda box cutters		
39		Coda box cover		
40		Last Blade		

### 13. REMOTE CONTROL JOYSTICK CALIBRATION

In the off state to a neutral position of the joystick, the left side of the remote control trim left to play, while the boot, the LCD screen displays all the characters, then put the rocker Hit the maximum and then slowly and completely with the rocker Circle, and ensure rocker hit corners. Then the left side of the remote control and then hit save and trim left Exit.

Specifications, contents of parts and availability are subject to change, Align RC is not responsible for inadvertent errors in this publication.

## Specifications & Equipment

**Length:** 510mm

**Height:** 170mm

**Main Blade Length:** 400mm

**Tail Rotor Diameter:** 128mm

**Weight(without Power System):** 305g

