

Automotive Relay	KA
------------------	----

**Features**

- Compact size
- 20A switching capability
- Small size auto relay



**cULus**  
(File No.:E122258)

**1. COIL DATA (at 20°C)**

1) Coil Power “L” Type

Nominal Voltage (VDC)	Pick-up Voltage (VDC)	Drop-out Voltage (VDC)	Max Allowable Voltage (VDC)	Coil Current (mA)(±10%)	Coil Resistance (Ω)	Coil Power (mW)
6	3.90	0.48	7.80	100	60 x (1±10%)	600
9	5.85	0.72	11.7	66.7	135 x (1±10%)	
12	7.80	0.96	15.6	50.0	240 x (1±10%)	
24	15.6	1.92	31.2	25.0	960 x (1±10%)	

2) Coil Power “D” Type

Nominal Voltage (VDC)	Pick-up Voltage (VDC)	Drop-out Voltage (VDC)	Max Allowable Voltage (VDC)	Coil Current (mA)(±10%)	Coil Resistance (Ω)	Coil Power (mW)
6	3.90	0.48	7.80	133	45 x (1±10%)	800
9	5.85	0.72	11.7	88.9	100 x (1±10%)	
12	7.80	0.96	15.6	66.7	180 x (1±10%)	
24	15.6	1.92	31.2	33.3	720 x (1±10%)	

**2. CONTACT DATA**

Contact Arrangement	1 Form A, 1 Form C	
Contact Resistance	100mΩ Max (at 1A 6VDC)	
Contact Material	AgSnO <sub>2</sub>	
Load	Resistive load (COSΦ=1)	
Contact Ratings	NO: 20A 14VDC    NC: 12A 14VDC    1C: 7A 120VAC	
Minimum Load	100mA 5VDC	
Max. Switching Voltage	250VAC / 16VDC	
Max. Switching Current	25A	
Max. Switching Power	840VA / 400W	
Life Expectancy	Electrical	100,000 operations (at 30 operations/minute)
	Mechanical	10,000,000 operations (at 300 operations/minute)

### 3. CHARACTERISTICS

Insulation Resistance		100MΩ Min. (at 500VDC)
Dielectric Strength	Open Contacts	500VAC 1min
	Contacts and Coil	500VAC 1min
Operate Time		10ms
Release Time		5ms
Temperature Range		-40℃ ~ 70℃
Shock Resistance	Operating Extremes	10G
	Damage Limits	100G
Vibration Resistance		10 ~ 55Hz, 1.5mm
Max. switching frequency	Mechanical	18,000 operations/hr
	Electrical	1,800 operations/hr
Humidity		35 ~ 85%
Termination		PCB
Weight		Approx. 6g
Outline Dimension (L x W x H)		15.7 x 12.3 x 14.0 mm

### 4. ORDERING INFORMATION

<u>KA</u> <u>1</u> - <u>L</u> <u>12</u> <u>S</u> ①   ②     ③   ④   ⑤	
① Relay Model	KA
② Contact Arrangement	11: 1 Form A (SPST-NO) 1: 1 Form C (SPDT)
③ Coil Power	L: 600mW D: 800mW
④ Coil Voltage	6=6VDC, 9=9VDC, 12=12VDC, 24=24VDC
⑤ Construction	S: Sealed Type

5. DIMENSIONS (Unit: mm)

Outline Dimensions

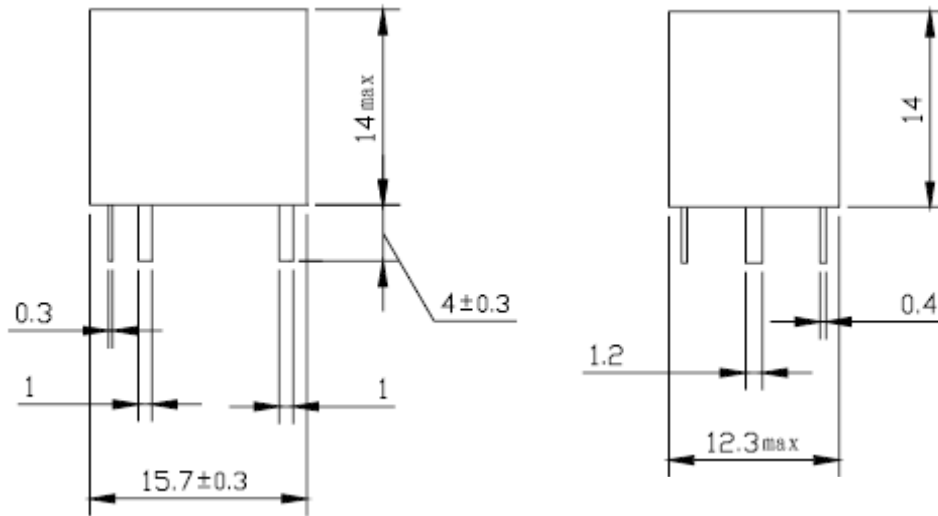

Wiring Diagram (Bottom View)

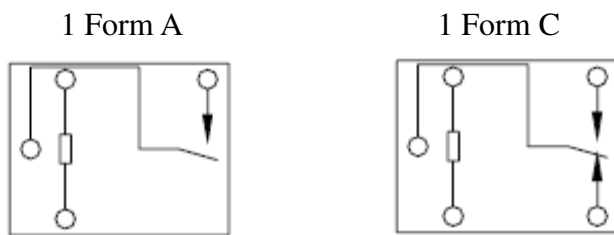

PCB Layout (Bottom view)

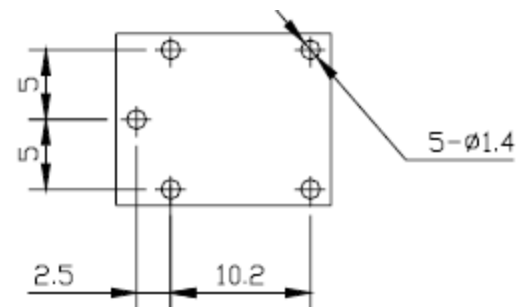

**Remark:** 1) In case of no tolerance shown in outline dimension: outline dimension  $\leq 1$ mm, tolerance should be  $\pm 0.2$ mm; outline dimension  $> 1$ mm and  $\leq 5$ mm, tolerance should be  $\pm 0.3$ mm; outline dimension  $> 5$ mm, tolerance should be  $\pm 0.4$ mm.

2) The tolerance without indicating for PCB layout is always  $\pm 0.1$ mm

## 6. CHARACTERISTIC CURVES

Service Life

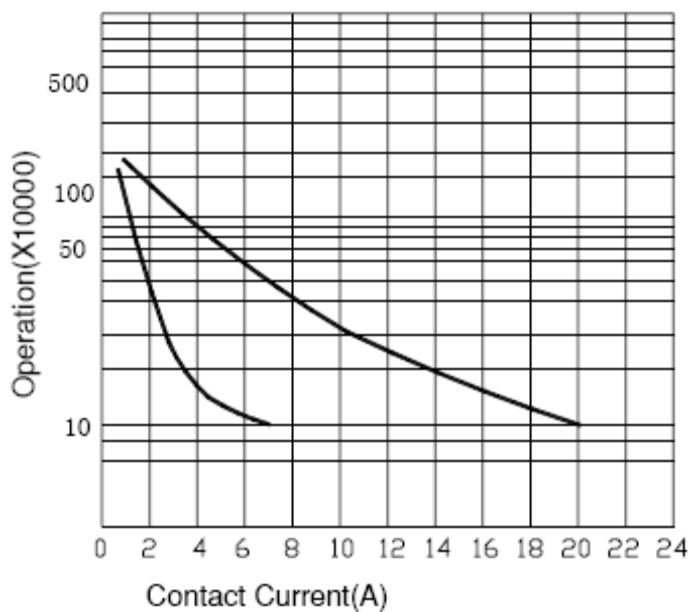

Current

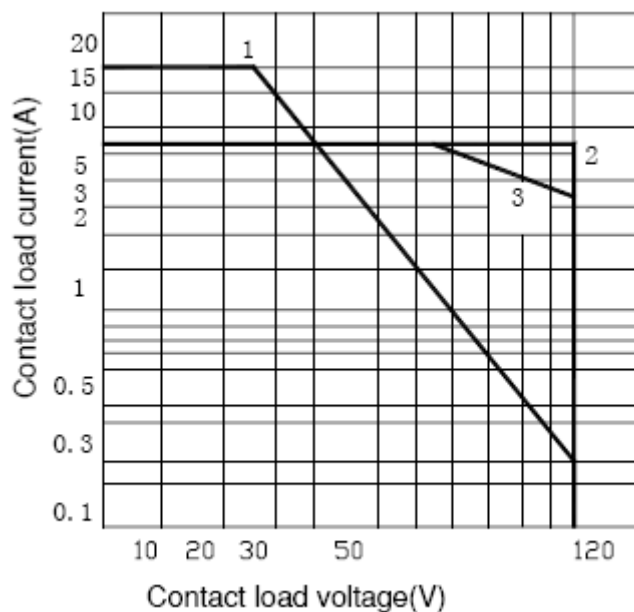

1. DC resistive 2. AC resistive 3. AC resistive

Temperature

