

WG Series Zero Power Consumption Sensor Choosing Guide

Product Function

WG Series Zero power Consumption Sensor is a new type magnetic sensor manufactured on the basis of WIEGAND effect. It doesn't external power supply when it works. It can directly transform the magnetic signal into Electrical signal. The sensor consists of an alloy wire which has been specially processed and the induction coil which is wound around the Wiegand wire.

This kind of alloy wire owns dual magnetic structure, its inner core is soft magnetism, and its shell is hard magnetic material. To utilize the difference of the inner and outer magnetic in the alloy wire, and is activated by the alternating magnetic field in proper strength, the magnetization direction of the inner core suddenly reversed, which is same with the housing's magnetization direction or the opposite directions, and the magnetic field around the alloy wire suddenly changes, and generates a pair of positive and negative electrical pulses in the induction coil. The amplitude of pulse is related to the strength of the excitation magnetic field, and is not related to the changing speed of the magnetic field.

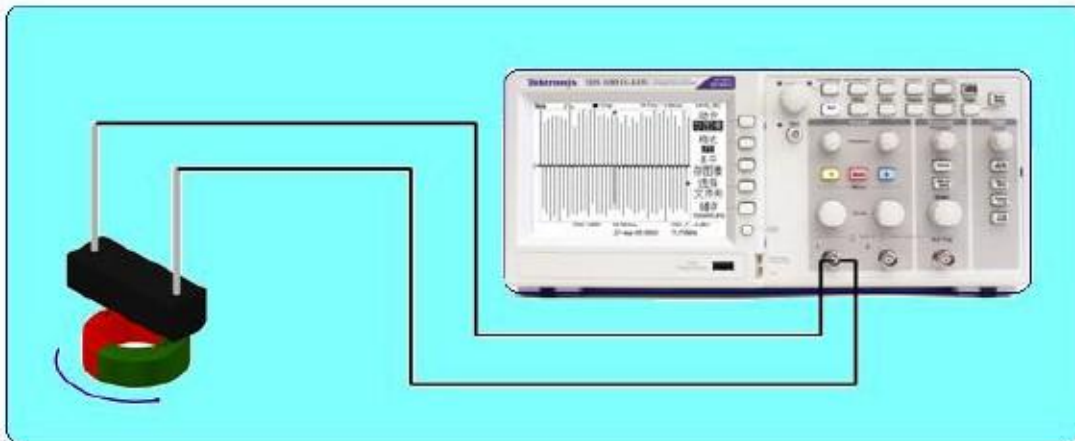



Product Application

- **Rotation Counting:** Intelligent water meter, heat meter, gas meter, oil meter, flow meter, odometer, etc.
- **Direction identification:** Reversible direction identification。
- **Position detection:** Oil depot level detection, tipping bucket udometer, unattended hydro-meteorological monitor etc.
- **Electronic switch:** **Flame-proof** switch, ignition switch.
- **Memory element:** **Encoder**, identification card, read out card, induction IC card gate control system.
- **Transient power :** Power type product can provide maximum energy of 4V, 1mA, 30 μ S, and can provide power to micro power devices.
- **Other application:** **vibration** detection, intelligent toys, no power pulse generator。



Product Characteristic

- It needn't power supply when it works.
- Double pole excitation working mode, when the magnetic field polarity changes for a circle, the sensor successively generates a pair of positive and negative electrical pulses in opposite polarity.
- When the polarity of the outside field changes and the magnetic strength reaches excitation threshold, the sensor will output a pulse signal, so it won't occur trembling and it works stable and reliable.
- The output signal amplitude is not related to the changing speed of field, and it can work under super low speed ("zero speed")
- Two leads are regardless positive and negative, it's convenient to use.
- The output signal can be transmitted in a long distance by signal wire, and it's suitable for LAN management.
- No mechanical contacts, no electric spark.
- Wide work temperature range, strong environmental suitability.
- Power type product can be used as transient power.

Parameter Index

Model		Signal Type					Power Type			
		WG112	WG113A	WG214	WG311	WG314	WG315	WG611	WG612	WG621
Magnetic Strength B (mT)	Min.	3	2.5	3		5		5		
	Typ.	5~6	7~8	5~6		7~8		7~8		
	Max.	12	15	12					12	
Output amplitude Vo (V)		≥1.5			≥2.0		≥3.0	≥6.0	20~50	
Pulse width (in 1V) τ (μS)		10~30					30~40		30~50	
DC internal resistance (Typ.) Ro (Ω)		700	1000	750	1500	650	1300	190	600	1400
Operating Frequency f (kHz)	Min.	unlimited					unlimited			
	Max.	10					5		1	
Operating Temp. T (°C)	Min.	-40	-20	-40			-40			
	Max.	+125	+85	+125		+100		+100		
Outer dimension. (mm)		12.8×4.5×4.5		12×7.2 ×8	φ4×11.5	φ3.3×22		24×6×	24×9×	18×6.7 ×11.8
Sensitive wire location (mm)		From the bottom of the sensor			central axis		central axis		See the figure	
		2		2.5						
Package		Plastic housing, Epoxy potting			Aluminium housing, Epoxy potting	heat shrinkage bush		Plastic housing, Epoxy potting		
Outer lead		Tinned copper hard leading wire		High temp. resistance soft leading wire	Tinned copper hard leading wire		Tinned copper hard leading wire			
Main application		Water Meter, Heat meter	Large caliber Water meter	Heat meter	Flow meter switch	Industrial flow meter, Pulse signal generator		Encoder, Transient power		
Remark		1: Special specification product can be customized. 2: 1 mT = 10 Gs								

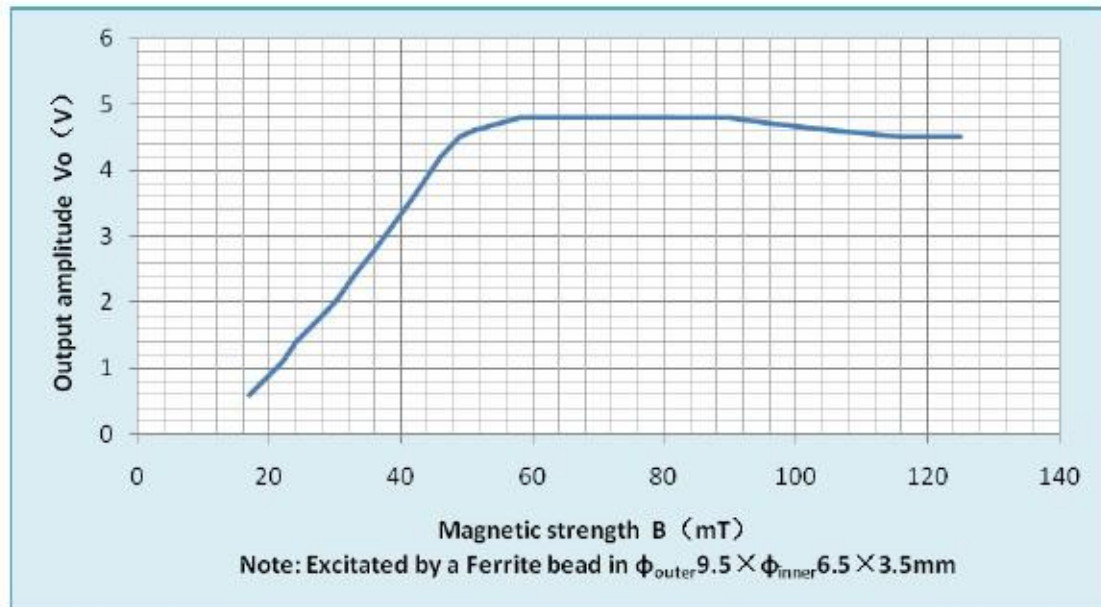
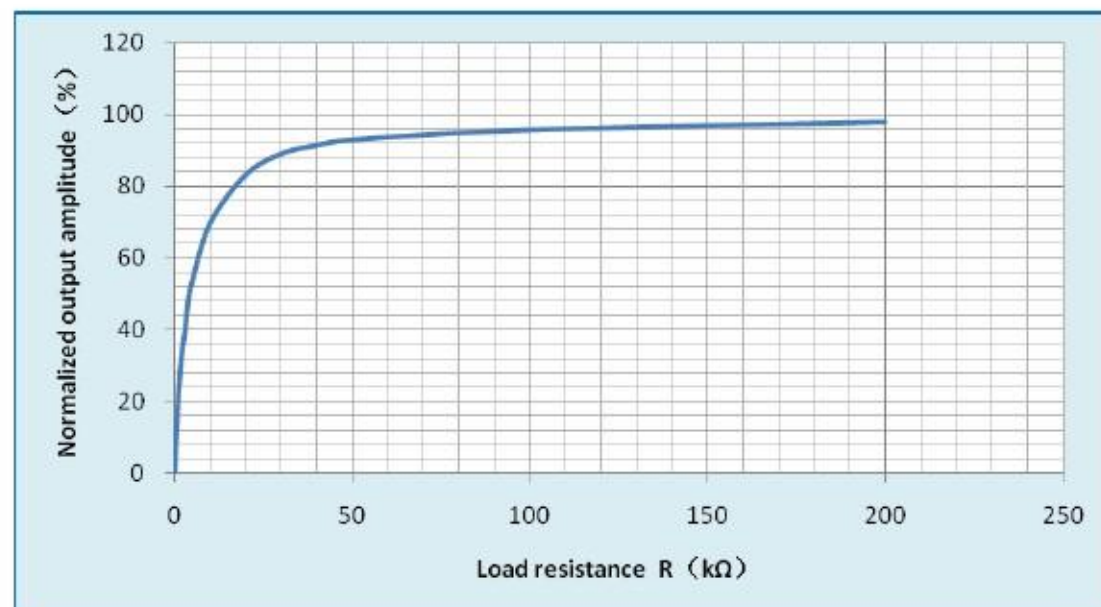
**Sensor output characteristic curve****● Output amplitude—excitation magnetic strength relation curve****● Output amplitude—load resistance relation curve**

- Output amplitude—Environmental Temperature relation curve

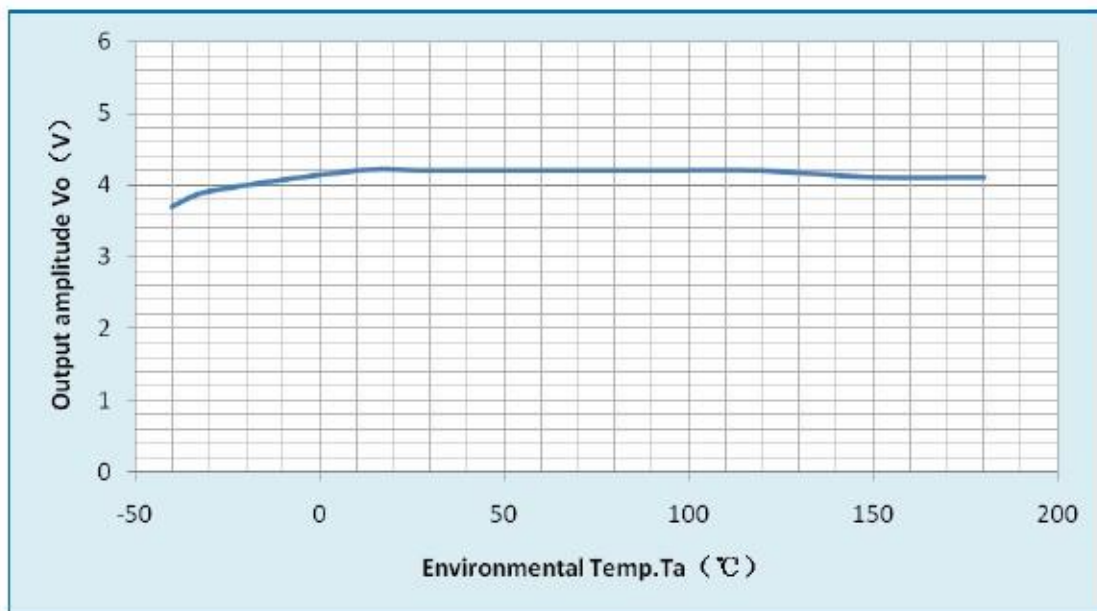

Using method and matters need attention

● Magnetic circuit design

The key whether the zero power consumption sensor can work normally is the magnetic circuit design. It should pay attention to the following points in the magnetic circuit design.

1. Alternately activated by N or S double poles, the distance between two poles should be near to or larger than the sensor's length.
2. The installation position of the magnet should ensure to be on the location of the sensitive wire and parallel to the magnetic-field component of sensitive wire, to meet the sensor's excitation demand, too high or too low magnetic field will affect the operating (see excitation magnetic strength in "Parameter index").
3. When operating in high temperature, it should remain some margin in the design of magnetic strength, as general magnet has a negative temperature coefficient.
4. When storing and using the sensor, it should avoid the attacking of strong magnetic field which is larger than 20mT, and it should pay attention to the electromagnetic shielding when using the product, and prevent the interference from the surrounding stray EM field.
5. For the magnet of same material and specification, as the discreteness of the component and the technology, there may have some difference in the magnetic strength, it needs to make a quality control to the magnet
6. The example: The following is the graph for the ferrite bead ($\phi_{outer}9.5 \times \phi_{inner}6.0 \times \phi$ 3.5) used in the water meter provided by three suppliers, it shows the attenuation of the horizontal component of magnetic strength ("B") with the height "h", on the height "h" from the surface of bead above the axial line.

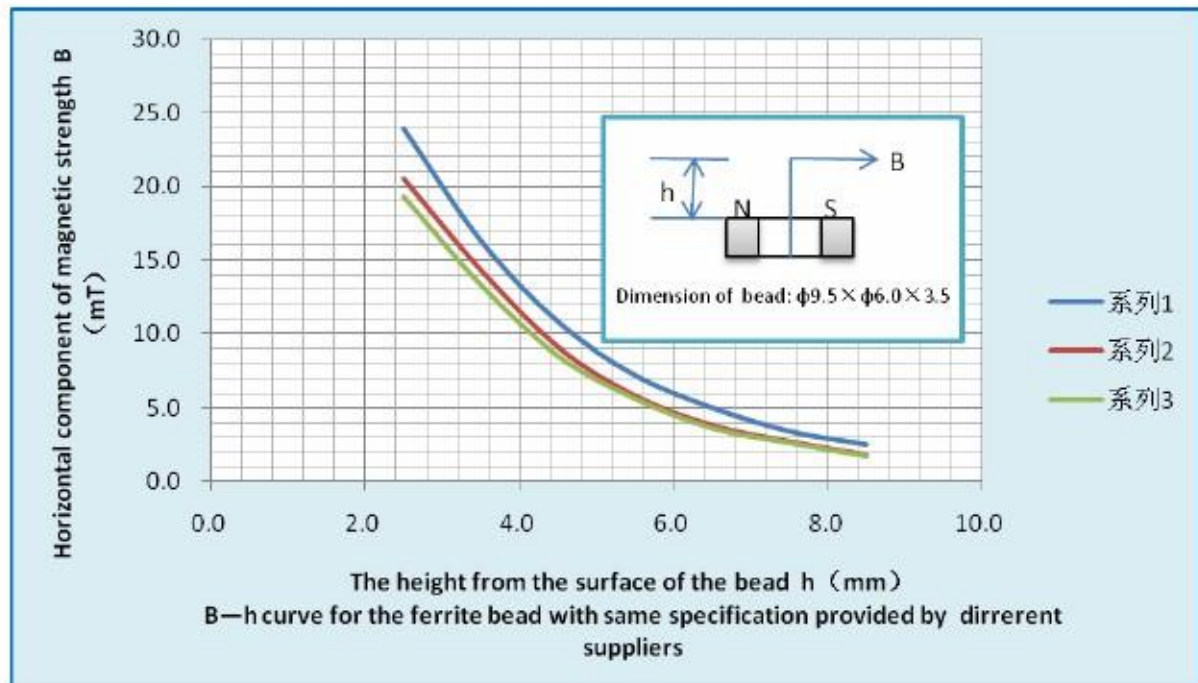

- **The installation mode of the sensor and magnet**

Several common installation modes :

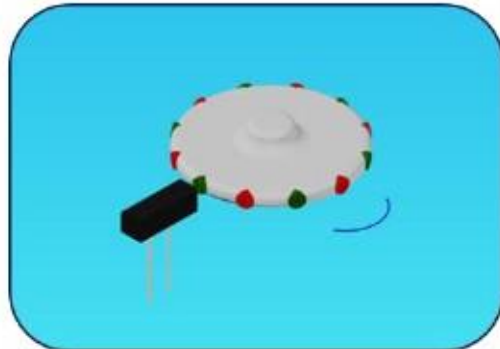
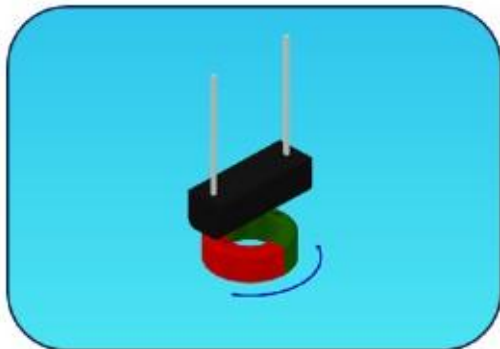
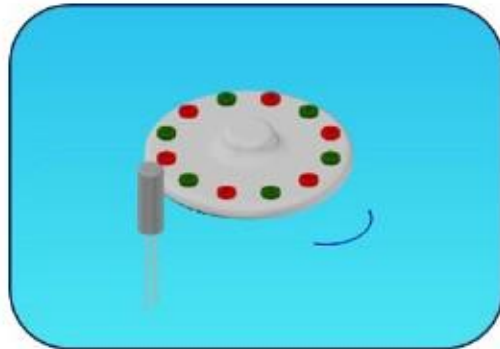

- **Electrical circuit design**

- The output signal of sensor can be directly connected with transistor, field effect transistor, comparer, or different operational amplifier. It can also be connected with micro power single chip after proper adjusting. When the sensor operates as rotation counting application, we suggest collect positive and negative pulse signals at the same time, and then switch-in the single chip after shaping.
- The welding temperature can't exceed 250°C , and the time should be less than 3 seconds.
- **Example**

The following graph is the shaping circuit for a universal sensor. The circuit is consists of one

NPN triode, one PNP triode, and several resistance-capacitances matched with it. The shaping circuit can transform a series of positive and negative bell shaped pulses of sensors into regular rectangle high-low level signals. If the sensor outputs positive pulse, and NPN collector-modulation will outputs a rectangle low level signal (please note that it's not negative pulse), and PNP doesn't output signal; in reverse, if the sensor outputs negative pulse, then the PNP collector-modulation will output a rectangle high level signal, but NPN doesn't output signal. Both amplitudes of High -low level are equal to supply voltage V_{cc} , the level widths are $20\sim 30\mu S$. The level signals being shaped can be convenient to be collected by the subsequent digital circuit.

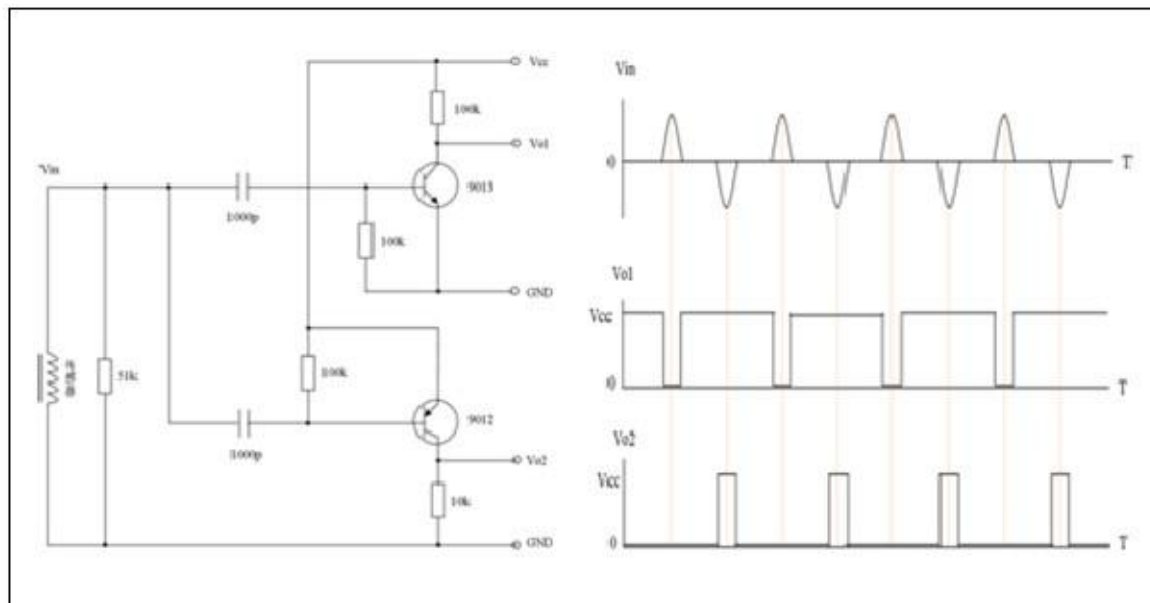

Shaping Circuit and its input and output waveform

● Software design

In order to valid prevent all kind of possible interference, when programming the single chip software, should pay attention to the following points: a) to separately collect the signals of the two output terminals on the shaping circuit on the two input terminals of the single chip; b) within $100\mu S$ whenever collecting one high level or low level signal, the single chip shouldn't continue

collect signal immediately, the software should arrange the single chip to do other work; c)

whenever collecting a pair of high-low level signals, the counter will counts “1” .

● **Packing, Transportation and Storage**

◆ **Packing**

The original packing of the product is antistatic plastic bag, external packing is carton.

◆ **Transportation**

The product in the packing carton is admitted to transport by transportation facilities. It should avoid insolation, raining or mechanical extruder during transportation. There should not have strong field around the product.

◆ **Storage**

The product should be stored indoors where is under normal temperature, dry, ventilating, no aggressive gas, and no strong field.