

Micro Switch

Version 03/16

Item no. 1426622

1. Features & Application

- Adopt thermosetting plastic or thermoplastic
- Small contact gap,snap action,high sensitivity and small operating travel
- Variety of levers
- Widely used in appliance,electronic equipment ,automatic machine,communication equipment,car electric,apparatus and instrument,electro motion tool etc

2. Model & Meanings

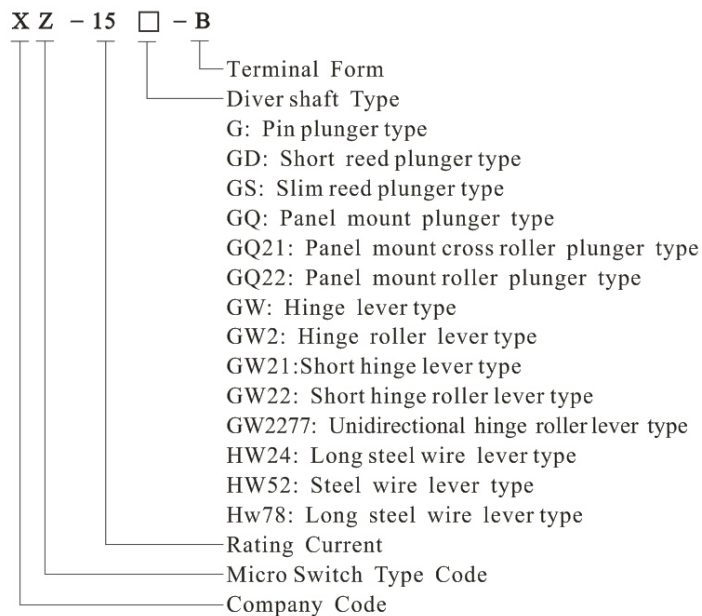

3. Technical Specification

Item	Data	
Operation speed	1mm-1m/s	
Operation frequency	Mechanical	240times / min
	Electrical	20times/ min
Insulation resistance	100MΩ	
Contact resistance	25 MΩ(initial value)	

Withstand Voltage	Non-connection wire	1000VAC
	Every terminal	1500VAC
Vibration	Misoperation	10-55HZ(amplitude)1.5mm
Impact	Durable	1000m/s
	Misoperation	300m/s
Life	Electrical	100,000times above
	Mechanical	1,000,000times above
Ambient operating temperature	-25-80℃	
Humidity	<85%	

Rating voltage (V)	Rating current (A)	Ith current (A)
AC-250	15	20
AC-125	15	20
DC-250	0.3	0.45
DC-125	0.6	0.75

4. Outshape and mounting dimensions.

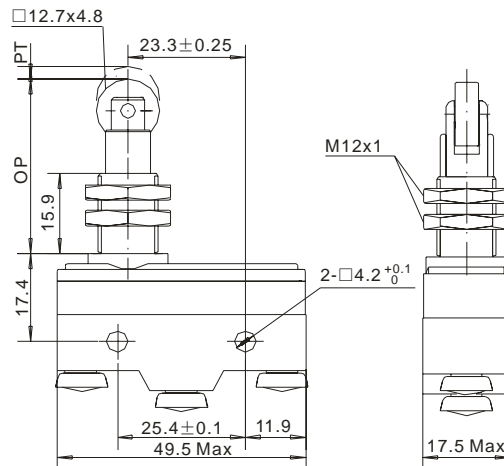

OF max.	500g
RF min.	120g
PT max.	0.5mm
OT min.	3.6mm
MD max.	0.05mm
OP	$33.5 \pm 1.2\text{mm}$

5. Mounting Hole

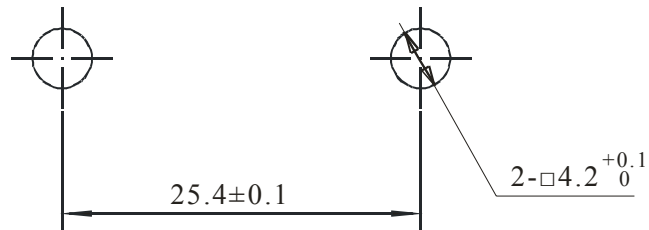

6. Contact Form

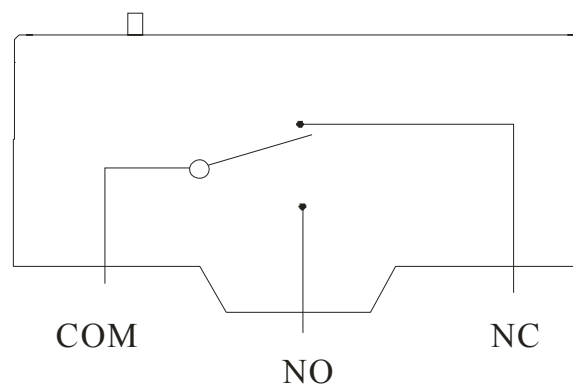

7. Structure

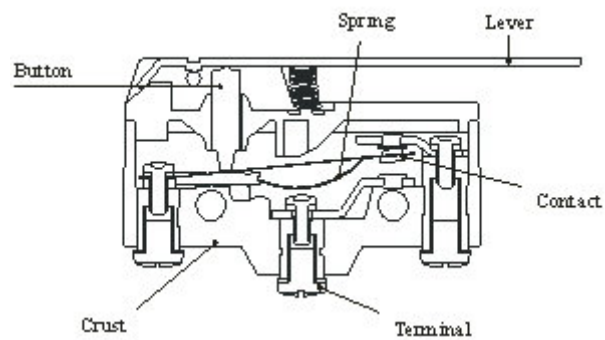

8. Terminal

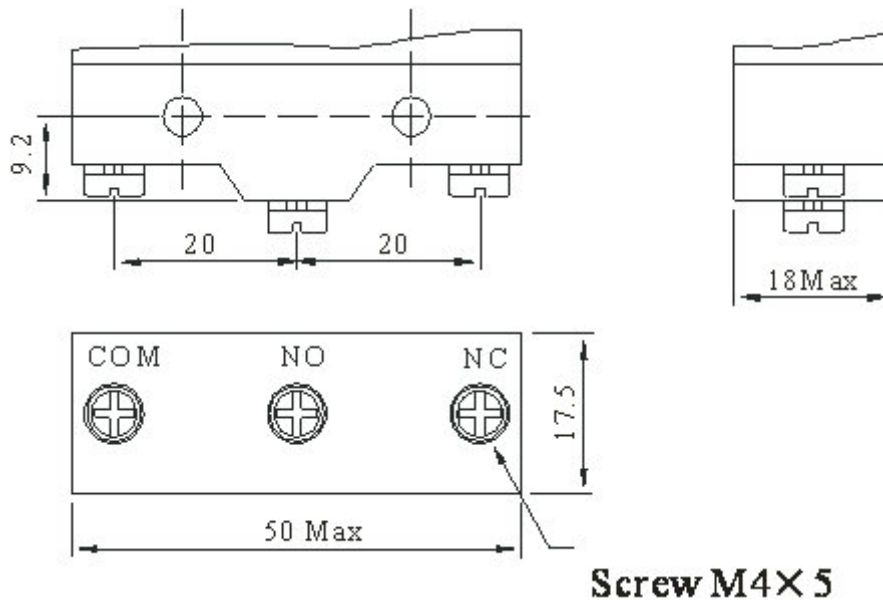

9. Certifications

CCC, CE, UL, TUV

10. Tolerance standard:

GB/T 1804-M

>6-30/±0.2

>30-120/±0.3

Distributed by Conrad Electronic SE

This data sheet is a publication by Conrad Electronic SE, Klaus-Conrad-Str. 1, D-92240 Hirschau (www.conrad.com). All rights including translation reserved. Reproduction by any method, e.g. photocopy, microfilming, or the capture in electronic data processing systems require the prior written approval by the editor. Reprinting, also in part, is prohibited. This data represent the technical status at the time of printing. Changes in technology and equipment reserved.

© Copyright 2016 by Conrad Electronic SE.