

Foot Switch

Version 03/16

Item no. 1426625

1. Features & Application

- Adopt metalshell, hard and strong in volume, stand wear and tear.
- Widely used in various of industrial machinery, just like industrial automation installment, transport, stamping, medical treatment, testing etc.

2. Model & Meanings

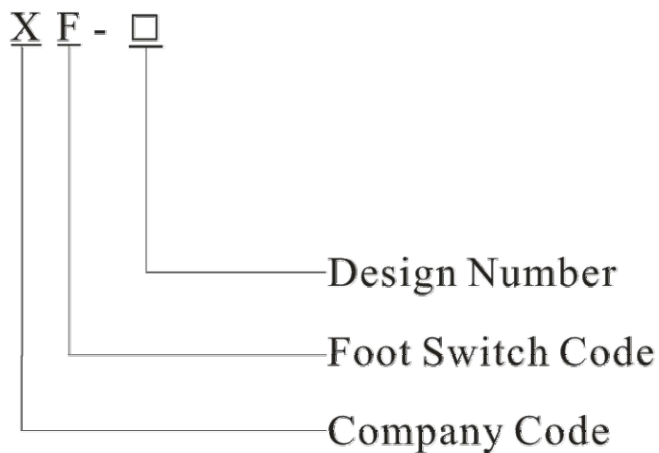

3. Technical specification

Item	Specification
Model Name	XF-402
Rating	15A 250VAC
Contact	1C
Material of Rind	Aluminum
Insulation resistance	$\geq 100M\Omega$
Contact resistance	$\leq 25m\Omega$
Withstand voltage	2000VAC
Electrical life	$\geq 100,000$
Protection degree	IP20
Temperature	-25-75°C
Humidity	< 85%

4. Outshape and mounting dimensions

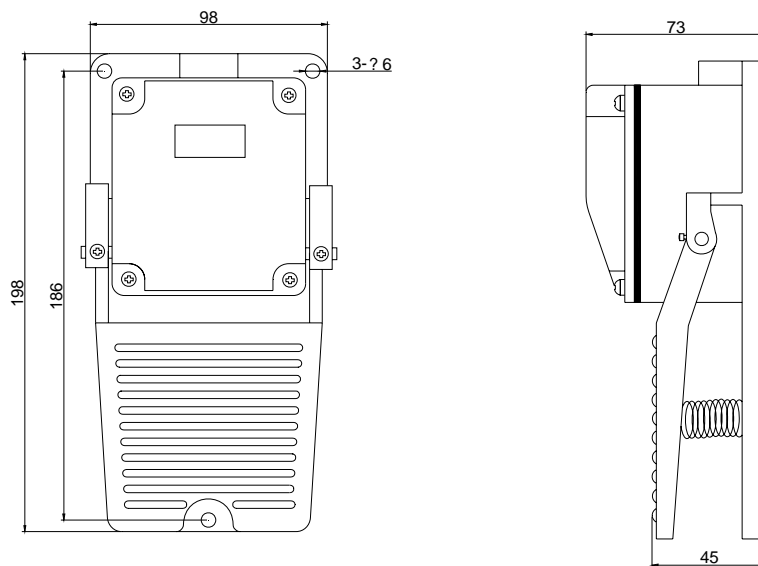

5. Connection Diagram

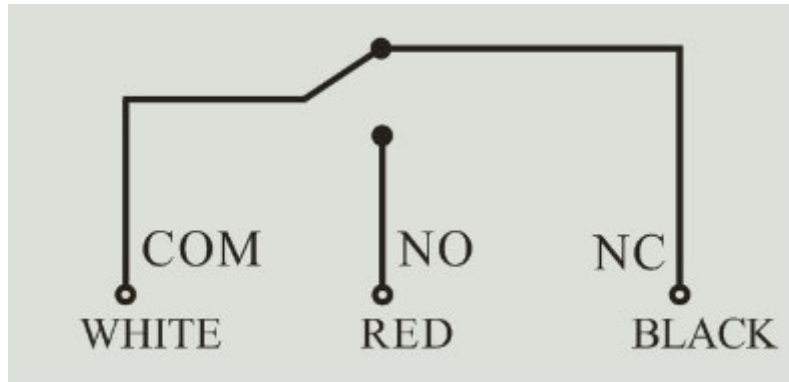

6. Certifications

CE,CCC,TUV

7. Tolerance: $\pm 0.5\text{mm}$

Distributed by Conrad Electronic SE

This data sheet is a publication by Conrad Electronic SE, Klaus-Conrad-Str. 1, D-92240 Hirschau (www.conrad.com). All rights including translation reserved. Reproduction by any method, e.g. photocopy, microfilming, or the capture in electronic data processing systems require the prior written approval by the editor. Reprinting, also in part, is prohibited. This data represent the technical status at the time of printing. Changes in technology and equipment reserved.

© Copyright 2016 by Conrad Electronic SE.