

Limit Switch

Item no. 1426631

Version 03/16

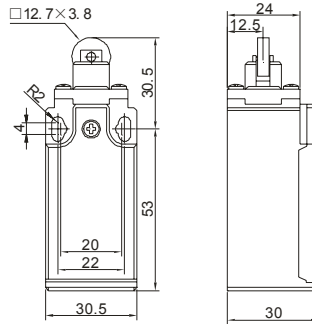

Connection

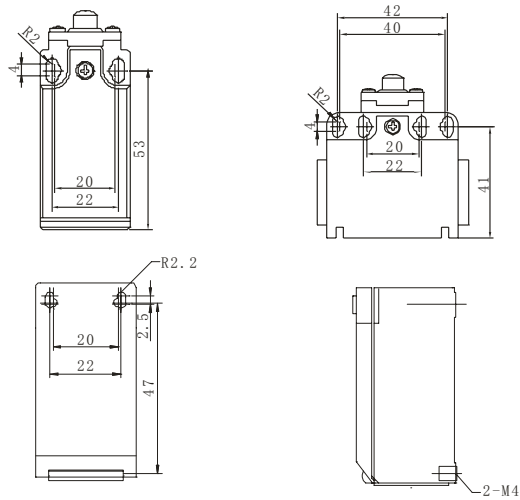
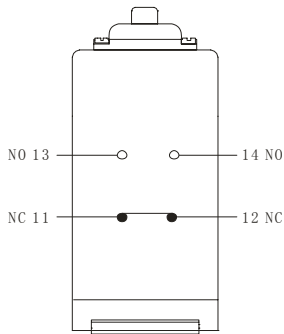

1 Housing Material.....	Thermoplastic cover
2 Contact material and plating.....	silver contact
3 Tolerance (Tolerance standard GB/T1804-m).....	>6-30/±0.2 ; >30-120±0.3
4 Rating load.....	10(4)A/250VAC,6(2)A 380VAC
5 Operation speed.....	5mm-0.5m/s
6 Insulation resistance.....	≥100MΩ(above)DC500V
7 Contact resistance.....	25mΩ(initial value)
8 Withstand voltage of Non-connection wire.....	1000VAC
9 Withstand voltage of Every terminal.....	1500VAC
10 Vibration Misoperation.....	10-55Hz Amplitude 1.5mm
11 Actuator type.....	Roller Button type
12 Electrical life.....	100, 000 above
13 Mechanical life.....	1,000, 000 above
14 Operating temperature.....	-10~70 Celsius degrees.
15 Operating humidity.....	< 85 %
16 Mechanical operation frequency.....	120 times/min
17 Electrical operation frequency.....	30 times/min

Distributed by Conrad Electronic SE

This data sheet is a publication by Conrad Electronic SE, Klaus-Conrad-Str. 1, D-92240 Hirschau (www.conrad.com). All rights including translation reserved. Reproduction by any method, e.g. photocopy, microfilming, or the capture in electronic data processing systems require the prior written approval by the editor. Reprinting, also in part, is prohibited. This data represent the technical status at the time of printing. Changes in technology and equipment reserved.

© Copyright 2016 by Conrad Electronic SE.