

1 . Electrical Characteristics

Resonant Frequency (KHz)	1.1± 0.5
Operating Voltage (Vp-p/max)	30
Rated Voltage (Vp-p)	5.0
Current Consumption (mA/max)	2.0 at Rated Voltage
Sound Pressure Level (dB/min)	85 at 10cm at Rated Voltage
Capacitance (pF)	48,000 ± 30% at 120 Hz
Operating Temperature (°C)	-20 ~ +90
Storage Temperature (°C)	-30 ~ +100
Manual soldering conditions	350±20°C / within 5sec

PS : Vp-p= 1/2duty , square wave

2 . Typical Frequency Response Curve

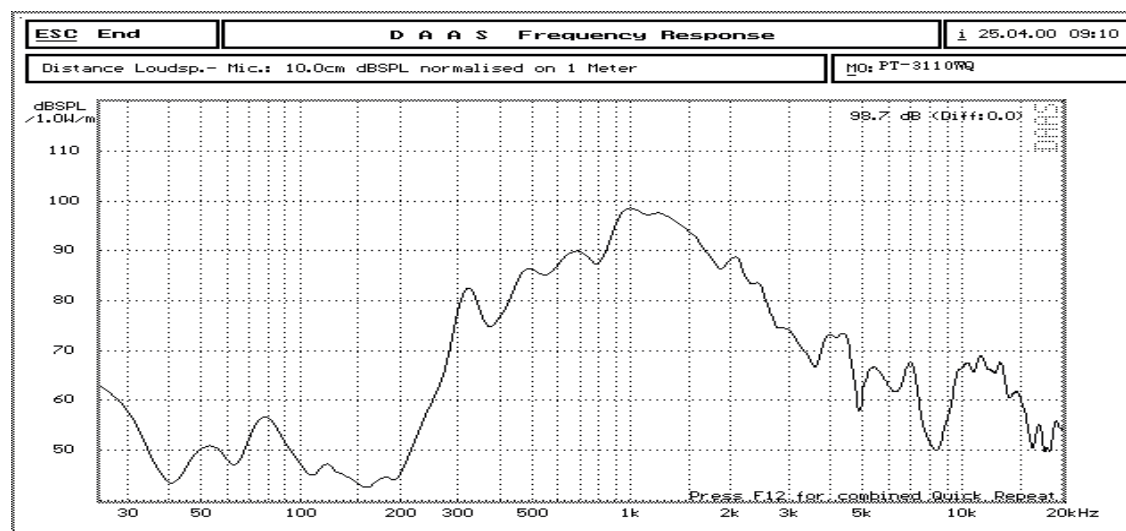

3 . Dimensions and Material

3-1 Shape

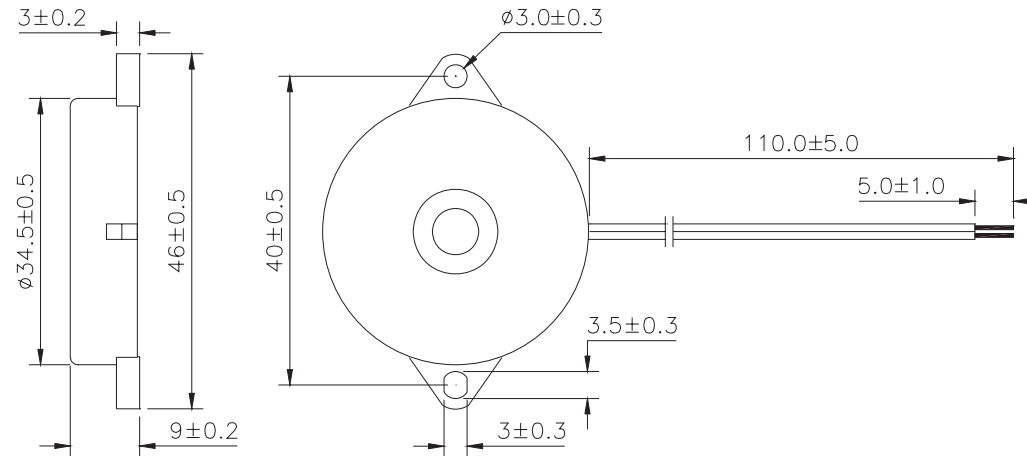

Unit:mm

3-2 Material

Housing	ABS 777D UL94HB plastic resin (Color : Black)
Leading Wire	28AWG (Red+Black)
Weight (Gram)	5.8

4. TESTING METHOD

• *Standard Measurement conditions*

Temperature: 25 ± 2 °C Humidity: 45-60%

• *Acoustic Characteristics*

The oscillation frequency, current consumption and sound pressure are measured by the measuring instruments shown below.

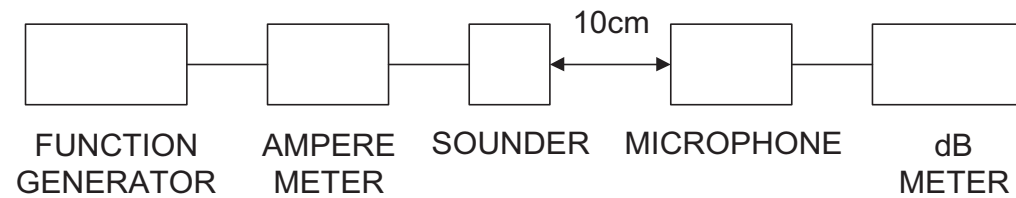

In the measuring test, buzzer is placed as follows:



5. RELIABILITY

ITEMS	METHOD OF TEST AND MEASUREMENTS	PERFORMANCE
Coldness withstanding	After 98 hours of being exposed to -30 °C environment, should be returned to normal environment for 2 hours, then re-proceed to test.	No abnormality shall exist
Hotness withstanding	After 98 hours of being exposed to +100 °C environment, should be returned to normal environment for 2 hours, then re-proceed to test.	No abnormality shall exist
Humidity withstanding	After 98 hours of being exposed to 40 °C 95%RH environment in actual operation, should be returned to normal environment for 2 hours, then re-proceed to test.	No abnormality shall exist
Durability	Testing after 1,000 hours actual continuous operation. (at standard measurement conditions)	No abnormality shall exist
Drop withstanding	A natural drop from 75cm high down to the ground.	No abnormality shall exist
Vibration withstanding	Vibration of 2,000 cycles per minute, 2mm amplitude, applied in X, Y and Z directions for 30 minutes each.	No abnormality shall exist

6. PACKAGE METHOD

<1> 200pcs per box , Total 10 boxes per carton , total 2000pcs carton;

Volume: L*W*H=510*330*300mm

<2> RoHS Mark

