

1 . Electrical Characteristics

Oscillation Frequency (Hz)	2500
Operating Voltage (Vp-p)	4.0 ~ 7.0
Rated Voltage (Vp-p)	5.0
Current Consumption (mA/max)	80 at Rated Voltage
Sound Pressure Level (dB/min)	85 at 10cm at Rated Voltage
Coil Resistance (Ω)	32 \pm 3
Operating Temperature ($^{\circ}\text{C}$)	-20 ~ +70
Storage Temperature ($^{\circ}\text{C}$)	-30 ~ +80
Condition by reflow soldering ($^{\circ}\text{C}$)	250 \pm 5 $^{\circ}\text{C}$ / within 5sec
Condition by hand ($^{\circ}\text{C}$)	350 \pm 20 $^{\circ}\text{C}$ / within 5sec

PS : Vp-p=1/2duty , square wave

2 . Typical Frequency Response Curve

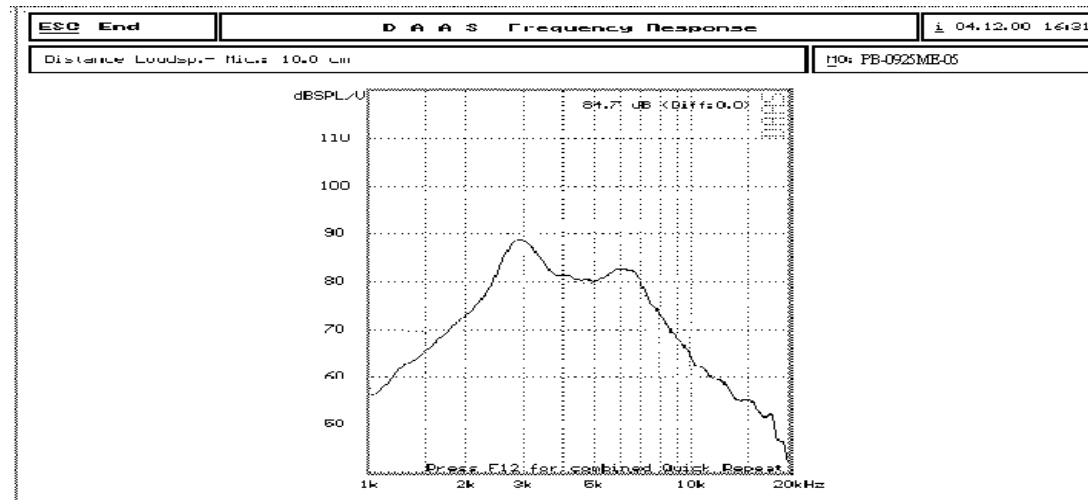

3 . Dimensions and Material

3-1 Shape

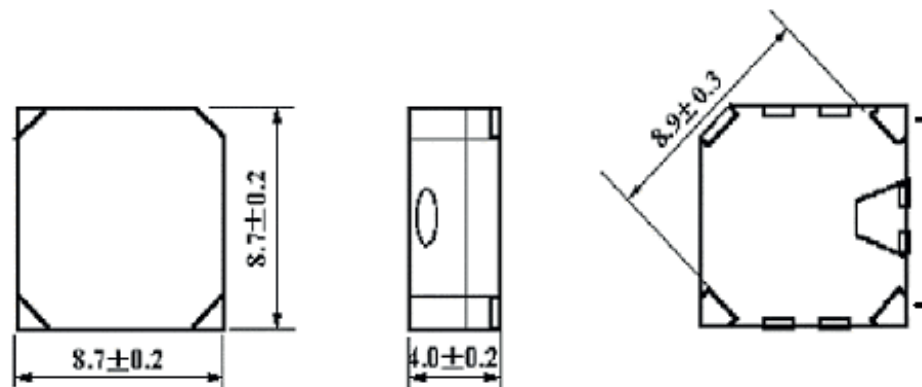

Unit : mm

3-2 Material

Housing	LCP plastic resin (Color : Black)
Type Of Connection Terminals	SMD
Weight (Gram)	0.6

4 . Recommend Driving Circuit

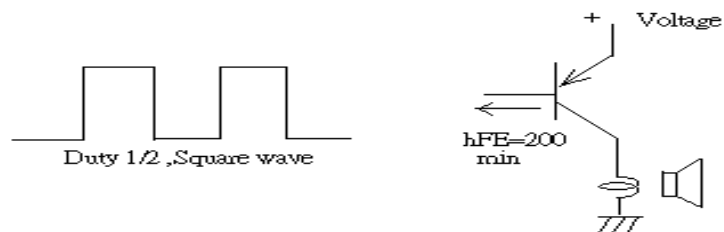

The base current I_b should high enough so that it saturates the collector current of the transistor with the CB load.

5. TESTING METHOD

• *Standard Measurement conditions*

Temperature: 25±2 °C Humidity: 45-60%

• *Acoustic Characteristics*

The oscillation frequency, current consumption and sound pressure are measured by the measuring instruments shown below.

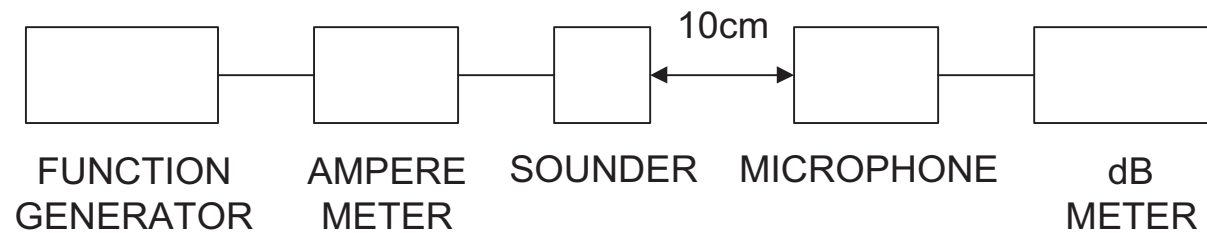

6. RELIABILITY

ITEMS	METHOD OF TEST AND MEASUREMENTS	PERFORMANCE
<i>Coldness withstanding</i>	<i>After 98 hours of being exposed to -30 °C environment, should be returned to normal environment for 2 hours, then re-proceed to test.</i>	<i>No abnormality shall exist</i>
<i>Hotness withstanding</i>	<i>After 98 hours of being exposed to +80 °C environment, should be returned to normal environment for 2 hours, then re-proceed to test.</i>	<i>No abnormality shall exist</i>
<i>Humidity withstanding</i>	<i>After 98 hours of being exposed to 40 °C 95%RH environment in actual operation, should be returned to normal environment for 2 hours, then re-proceed to test.</i>	<i>No abnormality shall exist</i>
<i>Durability</i>	<i>Testing after 1,000 hours actual continuous operation. (at standard measurement conditions)</i>	<i>No abnormality shall exist</i>
<i>Drop withstanding</i>	<i>A natural drop from 75cm high down to the ground.</i>	<i>No abnormality shall exist</i>
<i>Vibration withstanding</i>	<i>Vibration of 2,000 cycles per minute, 2mm amplitude, applied in X, Y and Z directions for 30 minutes each.</i>	<i>No abnormality shall exist</i>

7. PACKAGE METHOD

< 1 > 1000pcs per tape reel, Total 8 tape reels , total 8000pcs carton;

Volume: L*W*H=520*335*290mm

< 2 > N . W . : 4.8KGS ; G . W . : 6.0KGS ;

< 3 > RoHS Mark: