

Installing the Drive

Before installing the drive, turn off the system power.

1 Disconnect the power cord, and remove the cover.

- Remove a vacant 5.25" drive bay panel from the computer. Slide the drive into the drive bay.

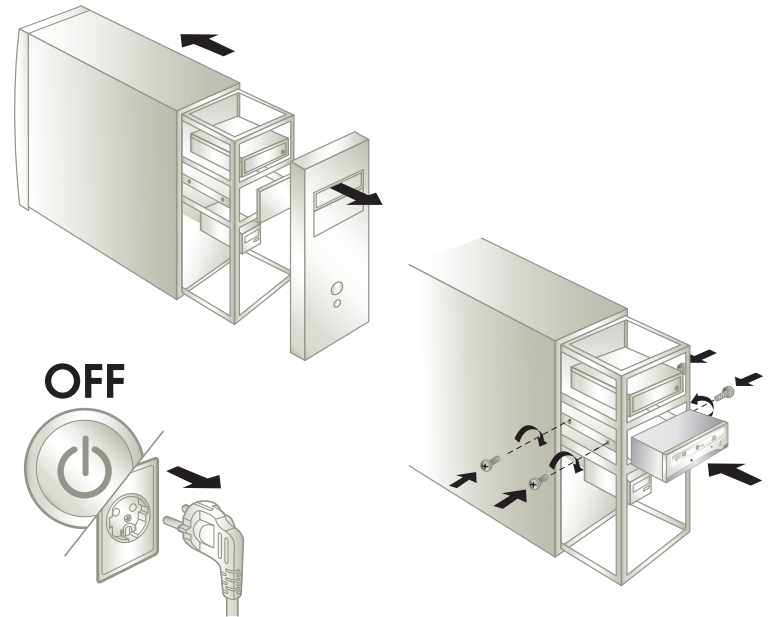

2 Connecting the SATA Power Cable

- Connect the power cable so the projection of the cable connector side to come to the left side. Be careful not to connect upside down.

NOTE:

Improper connection may damage the drive and void the warranty. Generally, the power connector can only fit one way.

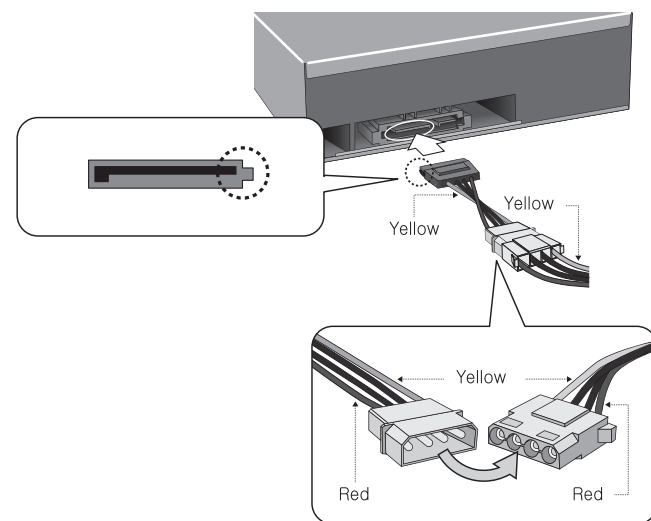

- Connect to the power connector of the PC.

3

Connecting the SATA Data Cable

- Connect the data cable. Be careful not to connect upside down.

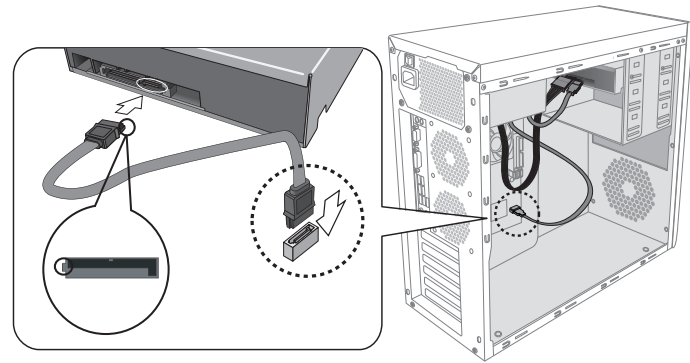

- Connect to the SATA connector on the PC's Motherboard.

4

Replace the cover, connect the power cord and restart your computer.

- Your computer configuration may differ from the illustrations.

NOTE

Please pay attention to handling Electrostatic Sensitive Devices, you may use anti-static products such as wrist straps, heel straps, mats to protect your body from electrostatic.

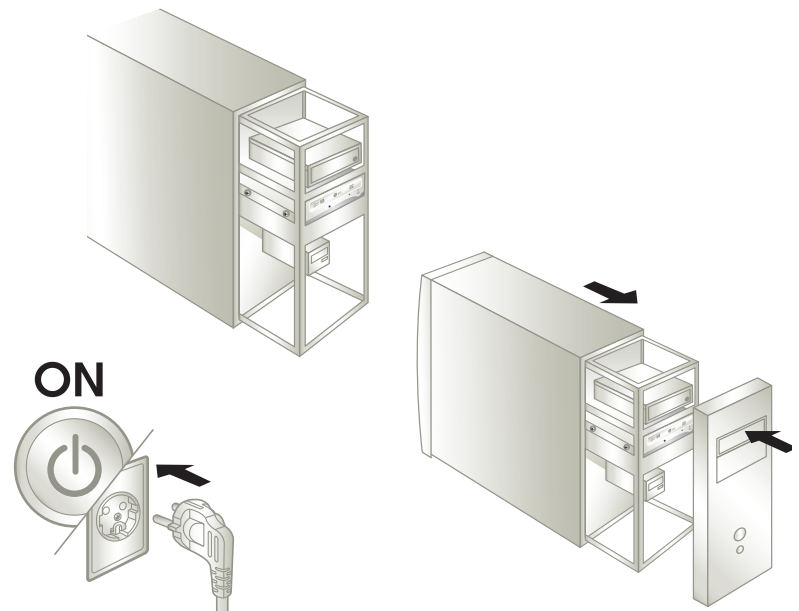



Quick Set-up Guide

Super Multi DVD Writer

GH24

To install of your product, please read this guide manual carefully and completely.

Features

- Serial ATA interface.
 - Power tray loading and ejection of disc. (The disc can also be ejected manually.)
 - Combination CD-R/RW, DVD-R/RW, DVD-R DL, DVD+R/RW, DVD+R DL, M-DISC (DVD+R SL), DVD-RAM Drive functions into one drive.
 - Supports Region playback control Phase II.
 - Automatic buffer underrun error prevention technology.
- You may experience lower write quality in case if you use disc products by some disc makers which those are not registered with the product's firmware. Therefore, it is recommended that you use only discs by recommended companies. And even if the write session is completed successfully, check the write quality before you put the disc in storage, especially in case of an important data backup. (Manufacturer is not responsible for any loss resulting from data backup failure.)
- Under Windows 8 operating system, a specific mainboard with nVidia GeForce 7025 Chipset may cause an abnormal operation.



MFL67902155

System Environment

Computer

This unit can be operated in the system environment explained here.

System requirements	CPU: Motherboard that supports Serial ATA. (Recommended Pentium IV 3.2GHz or higher.) RAM: 512MB or higher.
VGA Card Memory	128MB or higher.
Hard disk	20GB or more free space. (The free space needed for writing depends on the quantity of data.)
Interface	Serial ATA
Drive bay	13.34 cm (5.25-inch) half-height bay required
Power	+5V/+12V power socket required
Software Required OS	Windows 10, 8.1, 8, 7, Vista(X86, X64), XP [Home Edition/ Professional/Media Center Edition] with SP3 or higher, Direct X 9.0 or Higher is required.
Recommended media manufacturer	CD-R : LG, Mitsubishi Kagaku Media, Verbatim, Taiyo Yuden or TDK discs are recommended. CD-RW : Ricoh, Mitsubishi Kagaku Media, Verbatim discs are recommended. DVD-R : Mitsubishi Kagaku Media, Verbatim are recommended. DVD-RW : Mitsubishi Kagaku Media, Verbatim are recommended. DVD+R : Mitsubishi Kagaku Media, Verbatim are recommended. DVD+RW : Mitsubishi Kagaku Media, Verbatim are recommended. DVD-RAM : Maxell, Panasonic are recommended. M-Disc (DVD+R SL) : Millenniata DVD+R DL : Mitsubishi Kagaku Media, Verbatim are recommended. DVD-R DL : Mitsubishi Kagaku Media, Verbatim are recommended.

* Compatibility problem in write/read function may occur with media depending on the media manufacturing quality.

* Upon the media condition or some of user's environment the maximum speed sometimes could not be guaranteed.

* Please visit <http://www.m-disc.com> to learn more about the M-DISC™.

Specifications

Items	
General	
Host Interface	Serial ATA
Supported Discs	DVD-ROM(Single/Dual), DVD-RW, DVD-R, DVD-R Dual layer, DVD+RW, DVD+R, DVD+R Double layer, DVD-RAM, M-Disc (DVD+R SL), CD-Digital Audio & CD-Extra, CD-Plus, CD-ROM, CD-ROM XA-Ready, CD-I FMV, CD-TEXT, CD-Bridge, CD-R, CD-RW, Photo-CD (Single & Multi-Session), Video CD, DVD-VIDEO
Disc Diameter	12cm/ 8cm (8cm disc can be used only with drive placed horizontally.)
Mounting direction	Horizontal/Vertical
Read/Write Speed	
Write	DVD-R : 2 x, 4 x, 8 x, 16 x, 24 x DVD+R : 2.4 x, 4 x, 8 x, 16 x, 24 x DVD+R DL : 2.4 x, 4 x, 8 x DVD-RAM : 2 x, 3 x, 5 x CD-R : 16 x, 32 x, 40 x, 48 x
	DVD-RW : 2 x, 4 x, 6 x DVD+RW : 2.4 x, 4 x, 6 x, 8 x DVD-R DL : 4 x, 8 x M-Disc (DVD+R SL) : 4 x CD-RW : 4 x, 10 x, 16 x, 24 x
Read	DVD-ROM (Single/Dual) : 16 x/12 x max. DVD-R : 16 x max. DVD+R : 16 x max. DVD+R DL : 12 x max. DVD-RAM (Ver. 2.x) : 5 x max. CD-R/ROM : 48 x max. CD-DA(DAE) : 40 x max.
	DVD-RW : 13 x max. DVD+RW : 13 x max. DVD-R DL : 12 x max. M-Disc (DVD+R SL) : 12 x max. CD-RW : 40 x max.

* The drive's appearance and specifications may change without prior notice.

Items	
Burst transfer rate	SATA Gen.1 1.5 Gbps
Average Access Time(Random)	CD-ROM: 125 ms (Typical) DVD-ROM : 145 ms (Typical) DVD-RAM (Ver. 2.x) : 270 ms (Typical)
Buffer capacity	0.5 MB
MTBF	100000 Power On Hours (Duty Cycle 20 %)
Environmental Level	
When operating	Temperature : 5 °C to 40 °C Humidity : 15 % to 85 % R.H. (non condensing)
When not operating	Temperature : -30 °C to 60 °C Humidity : 10 % to 90 % R.H. (non condensing)
Electrical	
Power	DC 5 V, DC 12 V

Software

Install the appropriate CD Recording Authoring Software before using this unit.

* Please uninstall any previous CD burning software you may have loaded on your PC in order to prevent possible compatibility issues.

Once you have installed the application software, you may (if you wish) begin to reinstall previous software, taking note for errors.

We recommend using the drive with the latest software as some problems encountered when using the drive can be solved by updating the software.

Worldwide corporate site : <http://www.LG.com>

Safety Instructions

⚠ CAUTION: The laser used in the Drive can damage your eyes. Do not attempt to open the cover. To reduce the risk of electric shock, do not remove the cover (or back). There are no user-serviceable parts inside. Refer servicing to qualified service personnel. Use of controls or performance of procedures other than those specified herein may result in hazardous radiation exposure.

⚠ WARNING: To reduce the risk of fire or electric shock, do not expose this appliance to rain or moisture.

⚠ VORSICHT : Der in diesem Laufwerk benutzte Laser kann Ihre Augen schädigen. Versuchen Sie keinesfalls, die Abdeckung zu öffnen. Um die Gefahr eines elektrischen Schocks zu reduzieren, sollten Sie die Abdeckung (oder Rückseite) keinesfalls entfernen. Im Inneren des Geräts befinden sich keine Teile, die vom Benutzer selbst gewartet werden können. Überlassen Sie die Wartung qualifizierten Kundendiensttechnikern. Beachten Sie bei der Benutzung von Bedienelementen und der Durchführung von Prozeduren unbedingt die Anweisungen dieses Handbuchs, da andernfalls gefährliche Strahlung freigesetzt werden kann.

⚠ WARNUNG : Setzen Sie das Laufwerk keinesfalls Regen oder Feuchtigkeit aus, um die Gefahr eines Brandes oder elektrischen Schocks zu reduzieren.

⚠ ATTENTION: l'exposition au laser utilisé dans le graveur présente un danger pour les yeux. N'essayez pas d'ouvrir le capot. Afin de réduire les risques de chocs électriques, ne retirez pas le capot (ni l'arrière du dispositif). Aucune pièce interne ne peut être remplacée par l'utilisateur. Pour la maintenance de l'appareil, adressez-vous au personnel qualifié du service de maintenance. L'utilisation de commandes ou de procédures différentes de celles spécifiées ci-après peut entraîner une exposition à des rayons dangereux.

⚠ AVERTISSEMENT : Ne pas exposer ce matériel à la pluie ou à l'humidité (risques d'incendie et d'électrocution).

⚠ PERICOLO : Il dispositivo di lettura e scrittura utilizzato in questo masterizzatore utilizza un raggio laser che, se osservato da vicino, può danneggiare la vista. Evitare di smontare il coperchio dell'apparecchio. Al fine di prevenire eventuali folgorazioni, evitare di smontare l'apparecchio. All'interno dell'apparecchio non sono presenti parti che richiedono manutenzione da parte dell'utente. In caso di difetti o guasti, rivolgersi ad un Centro di Assistenza Tecnica. L'esecuzione di procedure diverse da quella espressamente indicate in questo manuale può provocare pericolose esposizioni alle radiazioni laser.

⚠ ATTENZIONE: Al fine di evitare cortocircuiti o principi di incendio, evitare di esporre questo apparecchio alla pioggia o ad una eccessiva umidità ambientale.

⚠ PRECAUCION: El láser utilizado en la unidad puede dañar sus ojos. No intente abrir la tapa. Para reducir el riesgo de descarga eléctrica, no quite la tapa (ni la parte posterior). No hay piezas internas que deba mantener el usuario. El servicio de mantenimiento debe efectuarlo personal técnico cualificado. El uso de controles o la ejecución de procedimientos distintos de los especificados en este manual pueden ser causa de exposición a radiación peligrosa.

⚠ ADVERTENCIA: Para reducir el riesgo de fuego o descarga eléctrica, no exponga este aparato a la lluvia ni a la humedad.

⚠ CUIDADO: O laser utilizado na unidade pode causar lesões oculares. Não tente abrir a tampa. Para reduzir o risco de choques elétricos, não retire a tampa (quer frontal quer superior). A unidade não contém peças que possam ser reparadas pelo utilizador. Deixe a manutenção para um técnico da assistência qualificada. A utilização de controlos ou a execução de procedimentos que não sejam os especificados neste manual podem causar a exposição a radiações perigosas.

⚠ AVISO: Para reduzir o risco de incêndio ou choque elétrico não exponha este aparelho à chuva ou humidade.

CLASS 1	LASER PRODUCT
KLASSE 1	LASER PRODUKT
LUOKAN 1	LASER LAITE
KLASS 1	LASER APPARAT
CLASSE 1	PRODUCTO LÁSER
CLASSE 1	PRODOTTO LASER

CAUTION : CLASS 3B VISIBLE AND INVISIBLE LASER RADIATION WHEN OPEN. AVOID EXPOSURE TO THE BEAM.

ADVARSEL : KLASSE 3B SYNLLIG OG USYNLLIG LASERSTRÅLING VED ÅBNING. UNDGÅ UDSÆTTELSE FOR STRÅLING.

ADVARSEL : KLASSE 3B SYNLLING OG USYNLLIG LASERSTRÅLING NÅR DEKSEL ÅPENS. UNNGÅ EKSPONERING FOR STRÅLEN.

WARNING : KLASSE 3B SYNLLING OCH OSYNLLIG LASERSTRÅLNING NÅR DENNALL DEL ÅR ÖPPNAD. STRÅLEN ÅR FARLLIG.

VARO! : KURSSI 3B NÄKYVÄ JA NÄKYMÄTÖN AVATTAESSA OLET ALTTIINA LASERSÄTEILYLLE. ÄLÄ KATSO SÄTEESEN.

The appliance is not intended for use by young children or infirm persons without supervision.

■ Microsoft® and Windows® are trademarks registered in the United States and other countries by the Microsoft Corporation.

■ The company names and product names written in this manual are trademarks or registered trademarks of the respective companies.

Caution!

The disc rotates at high speed in the drive unit. Use of worn, damaged, or non-standard discs can adversely affect the drive and cause the disc to shatter or crush while in use. Disc crush can only occur when you use a damaged disc in the drive. It is an extremely rare occurrence, but there are steps which can be taken to prevent it.

Always check your discs before inserting them into the drive.

1. Take care not to use worn, cracked, damaged, warped or poor quality discs, as this may cause damage to your drive.
2. Check the clear plastic on the center of the disc, cracks here are the main cause of disc crush.
3. Do not play discs which are a non-standard (i.e. non-circular) shape, such as heart shaped discs, or discs in the shape of a business card.

How can you keep your discs from becoming damaged?

1. When not in use, remove discs from the drive.
2. Keep discs in the packaging supplied with them and out of direct sunlight and away from heat sources.

Excessive vibration or a sudden jolt to the drive during operation may cause a malfunction. Avoid exposing the drive to sudden changes in temperature as it may cause condensation to collect inside the drive.