



5
YEAR

SATISFACTION
GUARANTEE

models
NGT335 & NGT425

WHOLE ROOM TOWER CIRCULATOR OWNER'S GUIDE

GUÍA DEL PROPIETARIO DEL CIRCULA-
DOR TORRE PARA TODO EL AMBIENTE

MODE D'EMPLOI DU VENTILATEUR
TOUR POUR TOUTE LA PIÈCE

READ AND SAVE THESE INSTRUCTIONS

LEER Y GUARDAR ESTAS
INSTRUCCIONES

LISEZ ET CONSERVEZ CES
INSTRUCTIONS

vornado.com

we expect
this product
to be **PERFECT**

if it's not,
WE will make
it right

vornado.com
800.234.0604
help@vornado.com

CONTENTS

Important Instructions	4	Troubleshooting	14
Features	7	Warranty.....	15
Getting Started	8		
Controls.....	10		
How To Use	11		
Remote Control.....	12		
Cleaning	13		

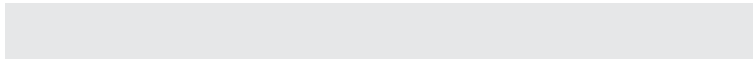

IMPORTANT INSTRUCTIONS

READ ALL INSTRUCTIONS BEFORE USING.

This owner's guide and any additional inserts are considered part of the product. They contain important information about safety, use and disposal. Before using the product, please familiarize yourself with all operating and safety instructions. Please keep all documents for future reference and pass these documents on, together with the product, to any future owner.

The following Warning messages are throughout this owner's guide:

DANGER

Indicates a hazard with a **HIGH** level of risk which, if not avoided, will result in death or serious injury. Please pay special attention to any instructions given to avoid this threateningly dangerous risk.

WARNING

Indicates a hazard with a **MEDIUM** level of risk which, if not avoided, could result in death, serious injury, minor or moderate injury or potential property damage.

INTENDED USE: This product is intended to circulate the air in indoor living spaces only. This product is not intended for commercial or industrial uses.

The manufacturer assumes no responsibility for damage or injury caused by failure to follow these instructions, improper product use or unauthorized product modification. Any such actions will invalidate the product warranty.

 **WARNING** – When using electrical appliances, basic precautions should always be followed to reduce the risk of fire, electric shock and injury to persons, including the following:

WARNING

Risk From Unintended Use and Handling. Please take care to follow these guidelines to avoid risks to people or property:

- **Do Not** tamper with or modify this product in any way.
- To reduce the risk of fire and electrical shock and injury to persons, **Do Not** use this product in a window.
- **Do Not** immerse this product in water or allow water to drip into motor housing.
- **Do Not** run cord under carpeting. **Do Not** cover cord with throw rugs, runners or similar coverings. **Do Not** route cord under furniture or appliances. Arrange cord away from traffic area and where it will not be tripped over.
- **Do Not** operate any product with a damaged cord or plug after the circulator malfunctions, has been dropped or damaged in any manner. Discard circulator, or return to authorized service facility for examination and/or repair in order to avoid a hazard.
- **Do Not** attempt to repair or replace parts.
- **Do** unplug your circulator before moving or cleaning.
- **Do** clean your circulator regularly. Refer to the CLEANING instructions provided. Never clean the air circulator in any manner other than as instructed in this manual.
- **Do Not** use gasoline, thinners, solvents, ammonias or other chemicals for cleaning.
- **Do Not** use near furnaces, fireplaces, stoves or other high-temperature heat sources.
- **Do Not** position this product too close to draperies because

- they may be drawn into the rear grill, cutting off airflow.
- **Do Not** carry this product by the cord or use the cord as a handle.
 - Use this circulator only as described in this manual. Any other use not recommended by the manufacturer may cause fire, electric shock or injury to persons.

DANGER

Risk From Electrical Shock. Contact with wires or components that are under voltage could be potentially fatal:

- **Do Not** use this product outdoors or exposed to weather or elements.
- **Do Not** use this product on wet surfaces. **Do Not** use this product in a bathtub or shower or position product where it may fall into a bathtub, laundry, swimming pool or other water container.
- **Do Not** use this product if it has a damaged power cord or plug. If the power cord is damaged, it must be replaced by the manufacturer, its service agent or similarly qualified person in order to avoid a hazard.
- To reduce the risk of fire or electrical shock, **Do Not** use this product with any solid state speed control device.
- **Do Not** stretch the power cord or put the cord under strain.
- **Do Not** insert or allow foreign objects to enter any input or output opening, as this may cause risk of electric shock, fire or damage to the product.
- **Do Not** open appliance housing. To avoid risk of shock, all service and/or repairs must be done by a Vornado Authorized Service Center. Only original replacement parts may be used.
- This appliance has a polarized plug. (One blade is wider than

the other.) To reduce the risk of electrical shock, this plug is intended to fit in a polarized outlet only one way. If the plug does not fit fully in the outlet, reverse the plug. If it still does not fit, contact a qualified electrician. **Do Not** attempt to override this safety feature.

WARNING

Risk From Electrical Connections. Please pay attention to any instructions given to avoid personal injury or property damage:

- A loose fit between wall outlet (receptacle) and plug may cause overheating and distortion of plug. Discontinue use of product in this outlet. Contact qualified electrician to replace loose or worn outlet.
- To disconnect circulator, turn controls off, then remove plug from outlet.

WARNING

Risk to Children and Other At-risk Groups of People:

- This appliance can be used by children ages 8 years and above and persons with reduced physical, sensory or mental capabilities or lack of experience and knowledge if they have been given supervision or instruction concerning use of the appliance in a safe way and understand the hazards involved.
- Children should be supervised to ensure that they do not play with the appliance.
- Cleaning and user maintenance shall not be attempted by children without supervision.
- This product and its packaging material are not toys and should be kept out of reach of children.

IMPORTANT INSTRUCTIONS

READ ALL INSTRUCTIONS BEFORE USING.

This product employs overload protection (fuse). A blown fuse indicates an overload or short-circuit situation. If the fuse blows, unplug the product from the outlet. Replace the fuse as per the user servicing instructions (follow product marking for proper fuse rating) and check the product. If the replacement fuse blows, a short-circuit may be present and the product should be discarded or returned to an authorized service facility for examination and/or repair.

User Servicing Instructions

Grasp plug and remove from the receptacle or other outlet device. Do not unplug by pulling on cord. Open fuse cover (A.) by sliding access cover on top of attachment plug toward blades. Remove fuse carefully (B.) by gently prying out the ends of the fuse from the receptacle.

Risk of fire. Replace fuse only with 2.5 Amp, 125 Volt fuse. Contact Vornado customer service for replacement fuse.
Phone: 1-800-234-0604 email: consumerservice@vornado.com

Install replacement fuse (C.) by first placing the end of the fuse into the fuse receptacle, which is opposite of the blades of the plug, then carefully push in the other end. Only push against the metal end of the fuse, not the glass center portion. Close the fuse access cover (D.) by sliding the cover back into the plug until it is completely closed, latches and is flush with the face of the plug. **Risk of fire.** Do not replace attachment plug. Contains a safety device (fuse, AFCI, LCDI) that should not be removed. Discard product if the attachment plug is damaged.

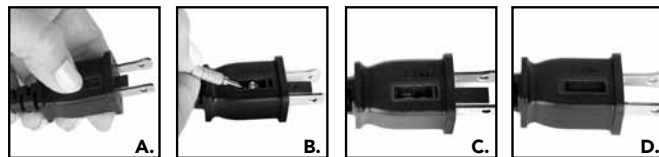

Note: This unit requires one (1) lithium coin cell battery (CR2032), 3 Volt (included). DO NOT DISPOSE OF BATTERIES IN FIRE. BATTERIES MAY EXPLODE OR LEAK.

WARNING: KEEP BATTERIES AWAY FROM CHILDREN. If batteries are swallowed, call the National Poison Control Center at 1-800-222-1222 or 202-625-3333. In Canada, call 416-813-5900.

WARNING: Changes or modifications to this unit not expressly approved by the party responsible for compliance could void the user's authority to operate the equipment.

This equipment may generate, use and/or radiate radio frequency energy that may cause harmful interference to radio communications. If this equipment does cause harmful interference to radio or television reception, which can be determined by turning the equipment off and on, the user is encouraged to contact Vornado Consumer Service at 1-800-234-0604.

SAVE THESE INSTRUCTIONS

Please keep all documents for future reference and pass these documents on, together with the product, to any future owner.

FEATURES

REMOVABLE INLET GRILL

For easy cleaning.

VERSA-FLOW™ ADJUSTABLE ANGLE AIRFLOW OUTLET

Direct the airflow up to 45 degrees

FINGER-FRIENDLY DESIGN

Resists curious fingers.

TOOL-FREE ASSEMBLY

Signature assembly for easy setup.

SILICON FEET

Non-marking feet added for stability.

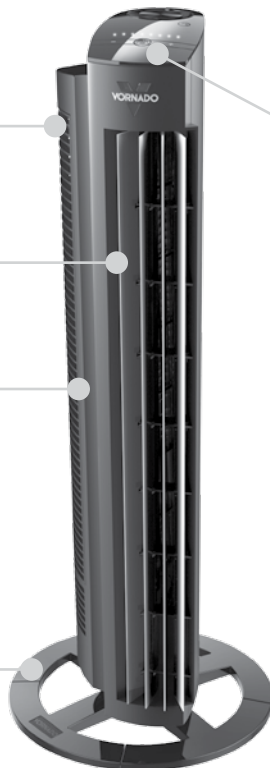

TOUCH-SENSITIVE CONTROLS

ENERGY-SAVING TIMER

1-8 hour timer.

MULTIPLE SPEEDS

5 speed settings for every comfort level.



REMOTE CONTROL

Convenience at your finger tips.

GETTING STARTED

BASE ASSEMBLY

1. Place tower circulator horizontally on a table with soft cloth underneath to avoid scratches. Allow base to extend over edge of table.

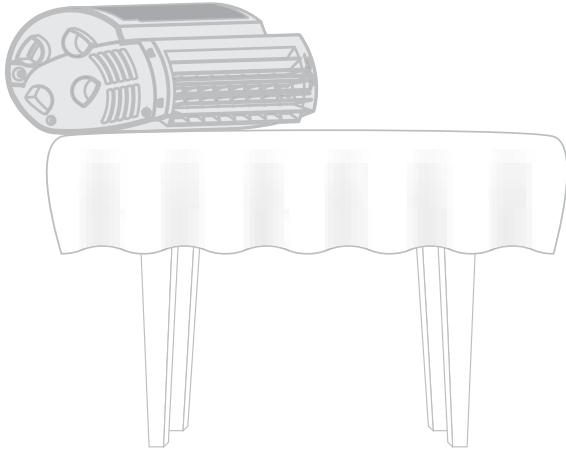

2. Insert one leg into any of four recesses underneath the tower. Push leg until it locks into place.

Note: To avoid damage, DO NOT FORCE legs into recessed areas — they should easily click into place.

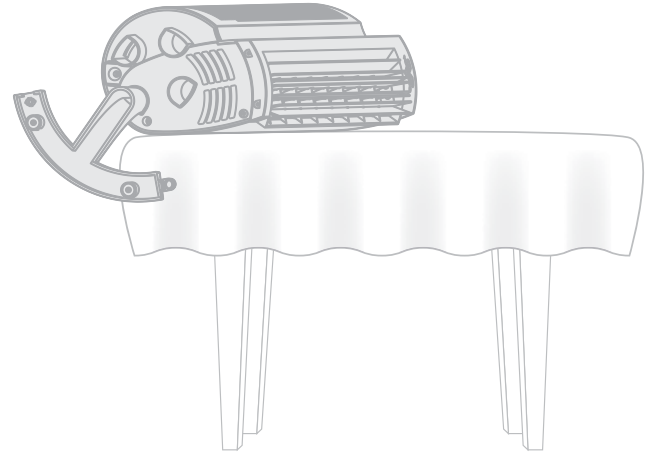

3. Next to previously installed leg, partially insert another leg into a recess on the base. Just before locking into place, connect both legs. Repeat for remaining legs.

Note: You may need to flex the legs to get the last of the legs to interlock.

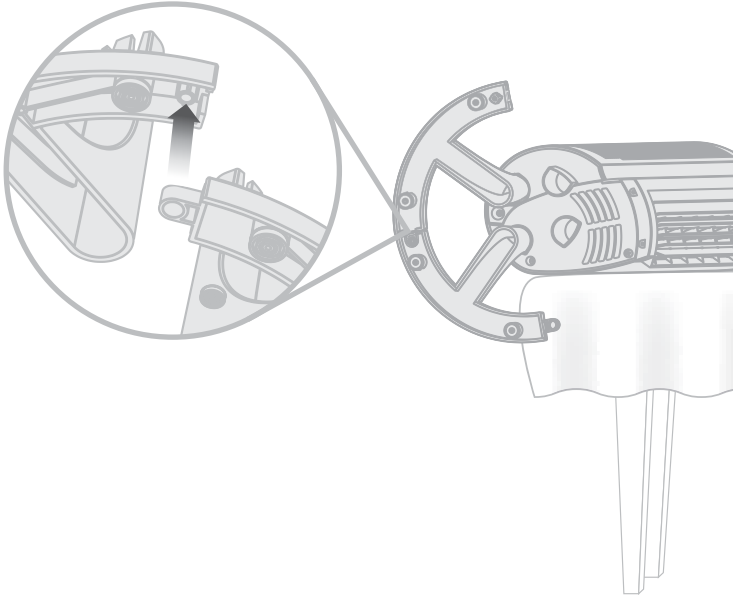

4. Base assembly is complete. Position tower circulator upright to begin use.

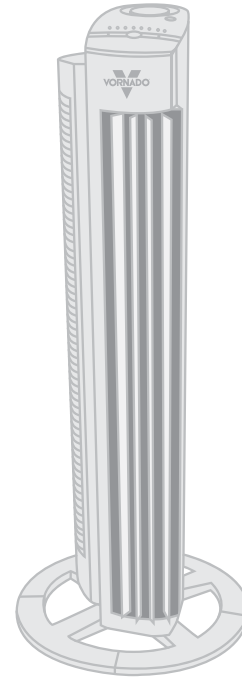

CONTROLS

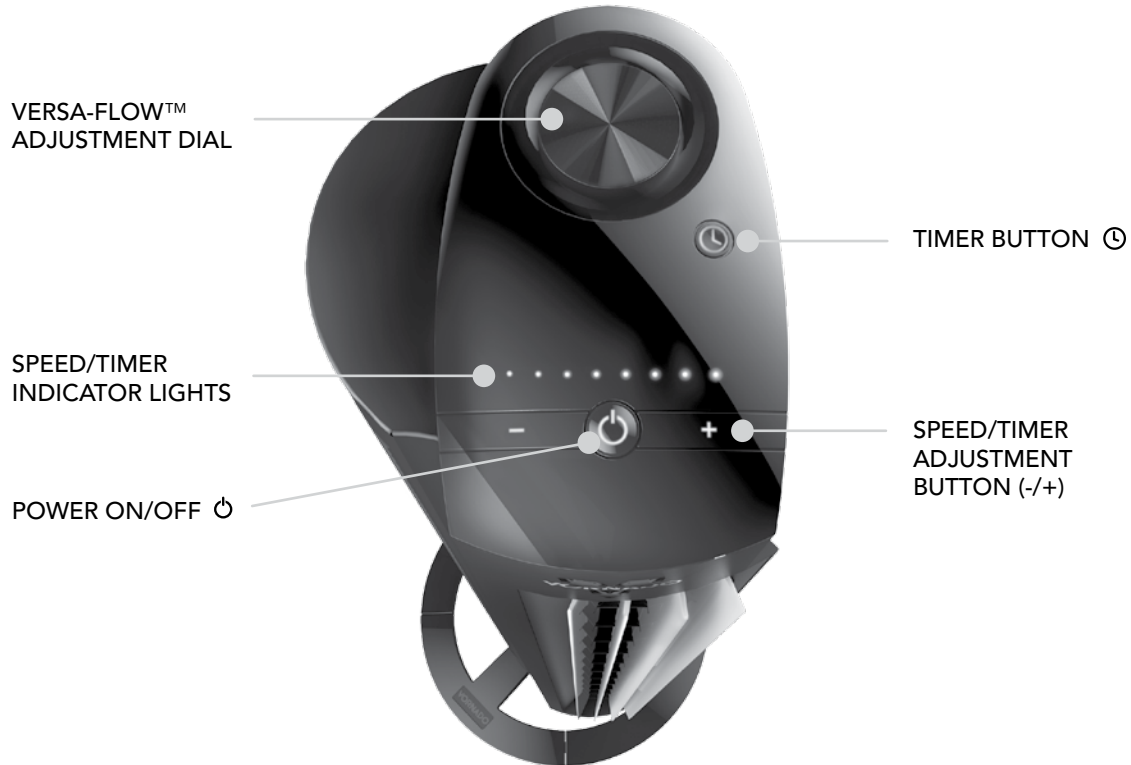

HOW TO USE

Before use, check appliance for visible damage. DO NOT USE THIS TOWER if there is evidence of damage. If any damage is found, contact Vornado Air LLC at 1-800-234-0604.



1. Touch  to power on.

2. Select desired speed by pressing -/+ .
Speed is indicated by number of lights illuminated:

Low speed	••
Low/Medium speed	••••
Medium speed	••••••
Medium/High speed	••••••••
High speed	••••••••••

Note: The display will dim after 3 seconds of inactivity.



3. Rotate Versa-Flow Adjustment Knob in either direction to adjust angle of airflow.



4. Press  to activate timer. The  and Indicator Lights will turn orange to indicate timer adjustment mode. While in this mode, select amount of time in one-hour intervals by pressing  OR -/+. After a few seconds, the flashing orange





Indicator Lights will turn white, indicating you have left timer adjustment mode.

Note: The display will dim after 3 seconds of inactivity.

The  will continue to glow orange to indicate the timer is set. Touch the  to quickly tell you how many hours are remaining on the timer.

5. To adjust timer, press  until Indicator Lights flash orange. Then press  OR -/+ to select new timer setting.

6. To cancel timer, press and hold  for 4 seconds or press  until all eight Indicator Lights are illuminated, then press  once more. All the lights will illuminate white, indicating the timer is off.

REMOTE CONTROL

Screwdriver required. 

Your tower circulator remote includes (1) coin style 3V CR2032 battery. Battery comes pre-installed. Remove battery pull tab before first use.

1. For battery replacement, the remote requires one coin style 3V CR2032 battery. Always use the correct size and grade of battery for this product.
2. To replace battery, open battery door on the back side of the remote control (you will need to loosen the small screw on door using a #1 Phillips screwdriver). If necessary, clean the battery contacts and also those of the device prior to battery installation. Remove any plastic protection from the battery and place it in the remote with the + side facing out. Ensure the battery is installed correctly with regard to polarity. Replace the battery door and screw.

Note: Remove battery from the remote control when not in use for an extended period of time and always remove dead battery immediately and replace with fresh. Do not store dead battery in remote.

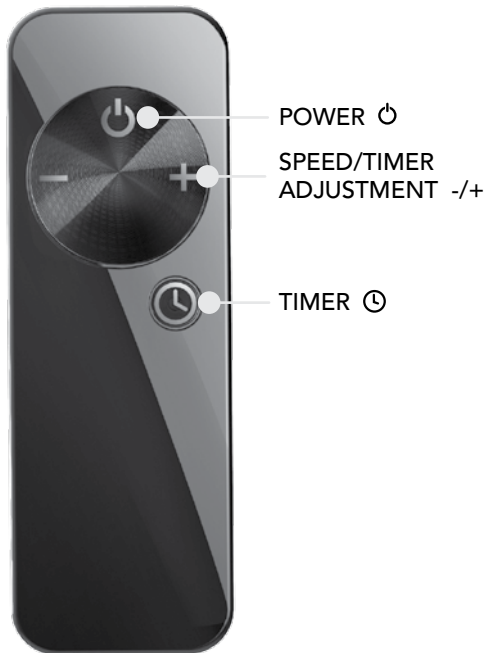

The remote control functions are the same as the control panel on the tower.

The remote requires a line-of-sight path to allow for the signal to be received by the tower. Position the tower so the receiver lens (inside the Vornado "V" logo) is visible from the remote control.

CLEANING

Because your tower moves a substantial amount of air, it will need regular cleaning. If service is required, return your tower to Vornado (see WARRANTY for instructions).

WARNING: To reduce the risk of electrical shock and injury to persons, unplug the tower before cleaning.

REGULAR CLEANING

1. Unplug tower before cleaning.
2. Use the brush attachment on your household vacuum cleaner to vacuum any accumulated dust off the tower.
3. Wipe down the entire tower with a soft cloth.

Note: Do not use gasoline, thinners, solvents or other chemicals for cleaning. The motor is permanently lubricated and requires no oiling.

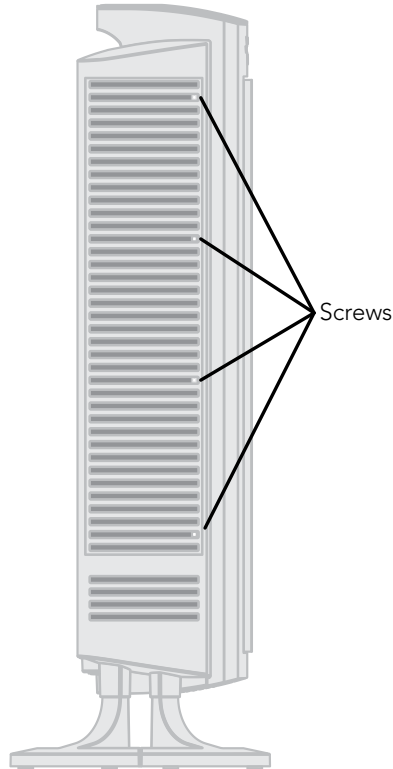

INTENSIVE CLEANING

AIR INLET GRILL REMOVAL

Screwdriver required. 

You may remove the Air Inlet Grill to vacuum any dust off the fan blade by following these instructions:

1. Unplug tower before cleaning.
2. Use a Phillips screwdriver to loosen the 4 screws located along front edge of grill.
3. Rotate front edge of grill backward until grill is removed.
4. Use the brush attachment on vacuum cleaner to remove any accumulated dust off the fan blade.
5. Replace Air Inlet Grill and tighten screws.

TROUBLESHOOTING

PROBLEM

POSSIBLE CAUSE AND SOLUTION

The unit fails to power on.

Unit is not plugged in. Plug Power Cord into electrical outlet.

Ensure unit fan speed setting is selected.

Plug fuse has blown. Replace fuse (Refer to IMPORTANT INSTRUCTIONS — User Servicing Instructions).

Unit is damaged or in need of repair. Cease usage and unplug. Contact Consumer Service for assistance.

The outlet is worn or damaged. Try another outlet or contact a qualified electrician.

Airflow is weak or slow.

Unit set to a low speed setting. Adjust to a higher speed setting.

Airflow is blocked. Remove obstruction.

Adjust direction of airflow toward the user.

GFCI has tripped.

Under certain conditions, it is possible for a reset (Ground Fault Circuit Interrupter) GFCI outlet to trip when the user is changing speeds on a Vornado circulator. In this event, change to an outlet that is not connected to a GFCI device. It could also indicate a weak or defective GFCI outlet. Contact a qualified electrician to check the GFCI outlet.

Remote control is not working.

The battery is dead. Replace with new 3 volt CR2032 battery. (Refer to REMOTE CONTROL.)

The remote requires a line-of-sight path to allow for the signal to be received by the unit. Position the unit so the receiver lens (inside the Vornado "V" logo) is visible from the remote control.



WARRANTY

We expect this product to be perfect. If you're not satisfied with this product, let us know.

We're Here to Help
800.234.0604
vornado.com
help@vornado.com

Vornado Air LLC ("Vornado") warrants to the original consumer or purchaser this Vornado® Whole Room Tower Circulator ("Product") is free from defects in material or workmanship for a period of five (5) years from the date of purchase. If any such defect is discovered within the warranty period, Vornado, at its discretion, will repair or replace the Product at no cost.

For warranty or repair service:

Call 1-800-234-0604 or email help@vornado.com to obtain a Return Authorization ("RA") form. Please have or include your Product's model number and serial number, as well as your name, address, city, state, Zip code and phone number when contacting Vornado for warranty service.

After receiving the RA form, ship your Product to:

Vornado Air LLC Attn: Warranty & Repair 415 East 13th Street, Andover, KS 67002. For your convenience, please have your model number and serial number when contacting Vornado with service inquiries. To ensure proper handling, packages must be clearly marked with the RA number. Packages not clearly marked with the RA number may be refused at the receiving dock. Please allow 1-2 weeks for repair and return of your Product after the Product is received.

Repairs not covered by the warranty or outside the warranty period will require a fee to cover the cost of materials, labor, handling and shipping. This warranty does not apply to defects resulting from abuse of the Product, modification, alteration, repair or service of the Product by anyone other than Vornado, mishandling, improper maintenance, commer-

cial use of the Product, damages which occur in shipment or are attributed to acts of God. REPAIR OR REPLACEMENT AS PROVIDED UNDER THIS WARRANTY IS THE EXCLUSIVE REMEDY OF THE CONSUMER. VORNADO SHALL NOT BE LIABLE FOR ANY INCIDENTAL OR CONSEQUENTIAL DAMAGES FOR BREACH OF ANY EXPRESS OR IMPLIED WARRANTY ON THIS PRODUCT. EXCEPT TO THE EXTENT PROHIBITED BY APPLICABLE LAW, ANY IMPLIED WARRANTY OF MERCHANTABILITY OR FITNESS FOR A PARTICULAR PURPOSE ON THIS PRODUCT IS LIMITED IN DURATION TO THE DURATION OF THIS WARRANTY. Some states do not allow the exclusion or limitation of incidental or consequential damages, or allow limitations on how long an implied warranty lasts, so the above limitations or exclusions may not apply to you. This warranty gives you specific legal rights, and you may have other rights that vary from state to state.

All company names and product names are trademarks of their respective owners. © All rights reserved. All technical information, data and instructions for the installation, connection and operation contained in these instructions for use correspond to the latest available information at time of printing. The contents of this manual may differ slightly from the actual product. Observe any additional supplements.

The manufacturer assumes no responsibility for damage or injury caused by failure to follow these instructions, improper product use or unauthorized product modification. Any such actions will invalidate the product warranty.

Any unauthorized product modification, repair by unauthorized repair center or use of non-approved replacement parts is not recommended and any consequences will not be covered by support services or product warranties.



Designed, engineered and supported in Andover, KS.

© 2016 Vornado Air LLC Andover, KS 67002 U.S. Patent Pending. Specifications subject to change without notice. Vornado® is a trademark owned by Vornado Air LLC.

esperamos que
este producto
sea **PERFECTO.**

si no lo es,
AYÚDENOS a
corregirlo

vornado.com
800.234.0604
help@vornado.com



Vornado Air, LLC
415 East 13th Street, Andover, Kansas 67002
800.234.0604 | vornado.com

CL3-0421 R-
CL7-0421 R-, V00