

PFF7815

Video Wall Floor Stand 3x3 for 55 Inch Displays

INSTALLATION INSTRUCTIONS



9589-008-Z00-01

Step 1

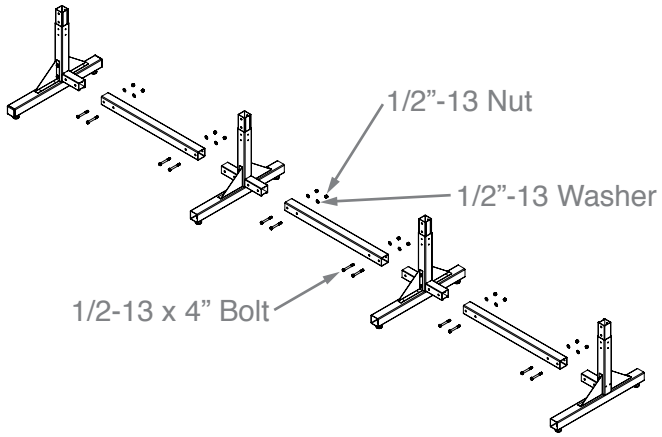

Step 2

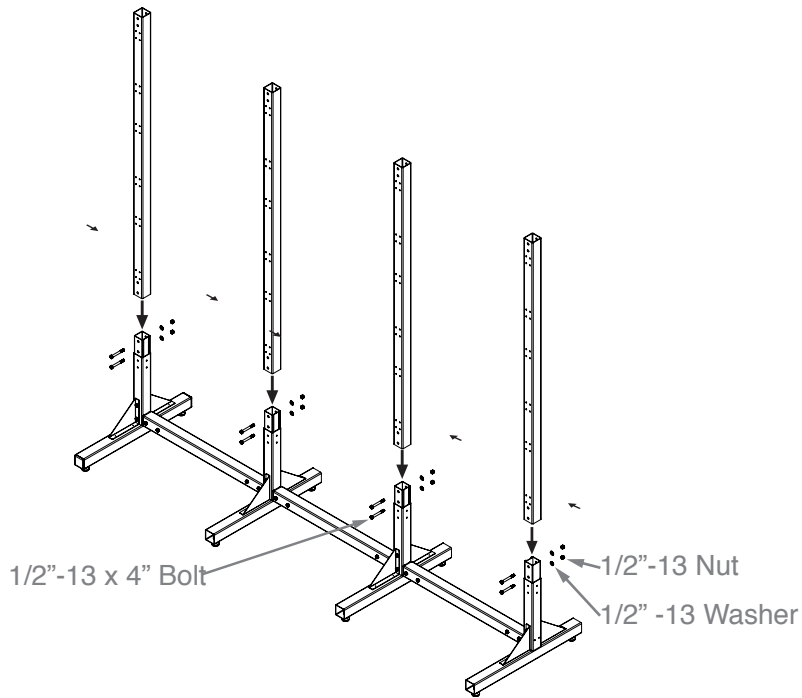

Step 3

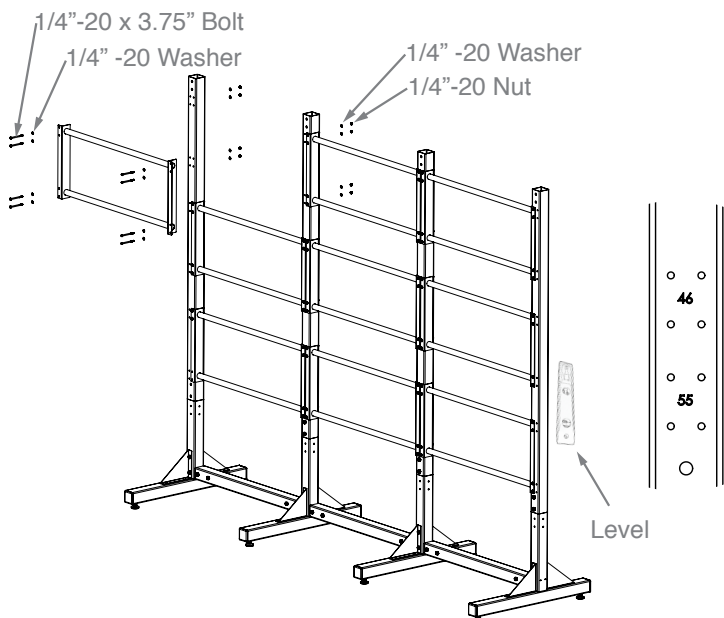

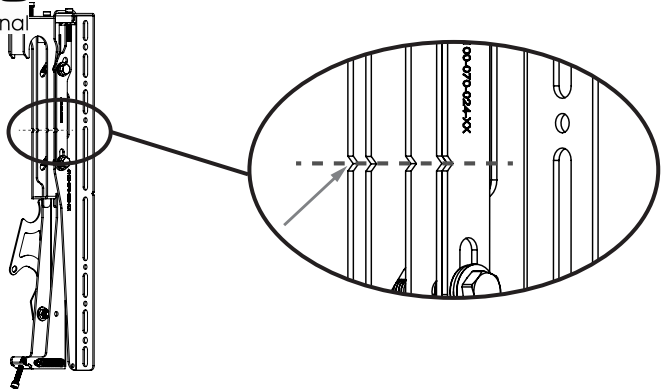

Step 4

Insure the three "V" alignment notches on each mounting bracket are at their factory preset center with all notches together to indicate you are in the center of your alignment adjustment field. If not in center alignment, adjust the top Allen head screw(s) to adjust the center to the correct starting position on each mounting bracket.

See arrow.

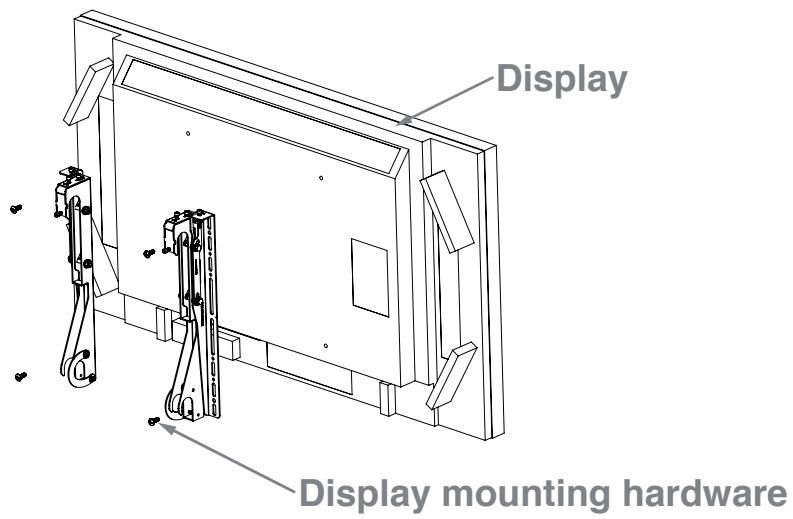

Install the left and right adjustable mounting brackets to the displays aligning the "V" notch on the display mounting plate to the rear center height of the display. See arrow to center notch.

Note: lower round security rings on the mounting bracket need to face to the center of the display. See arrow.

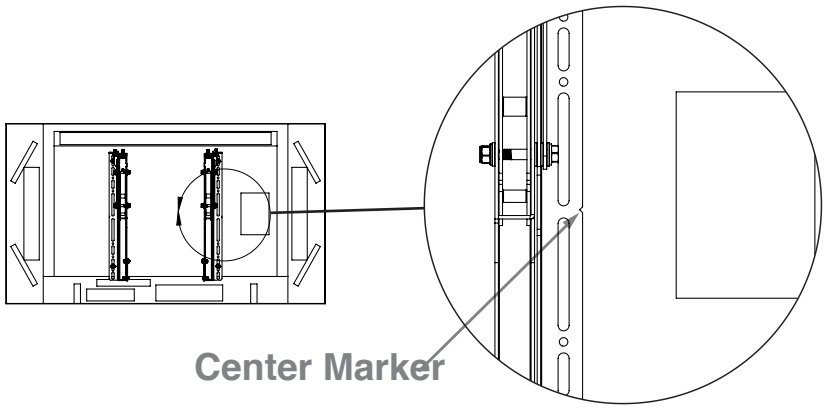

Once center of display alignment is confirmed, securely tighten all mounting bracket to display mounting screws with correct pitch hardware supplied.

Step 5

Start by installing the lower center monitor first to the video wall frame and loosely secure as shown.

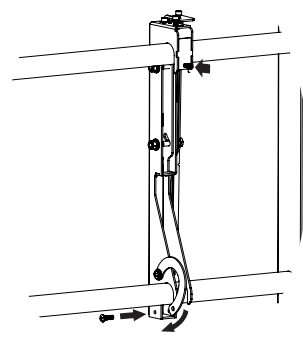
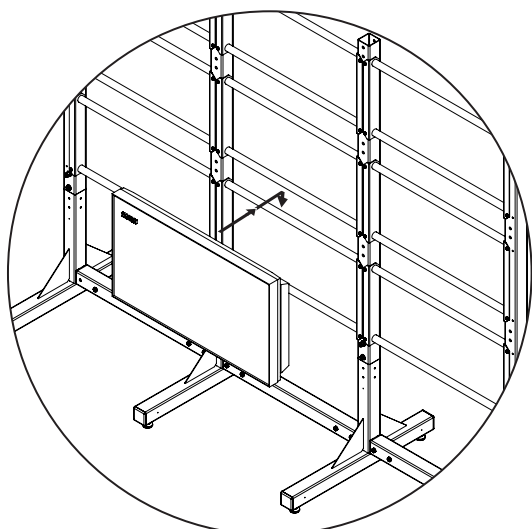
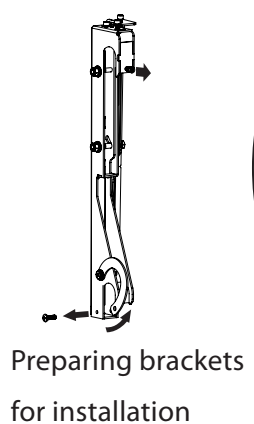

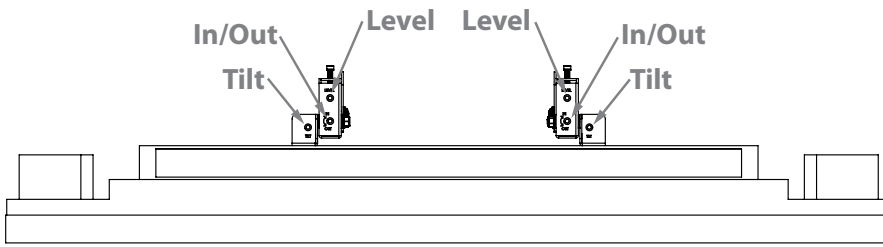

Now that you have your first lower center display attached to the frame, the beauty of the three part alignment features of the mounting bracket come into play. The fact that all the adjustments are on top will make the final adjusting effortless.

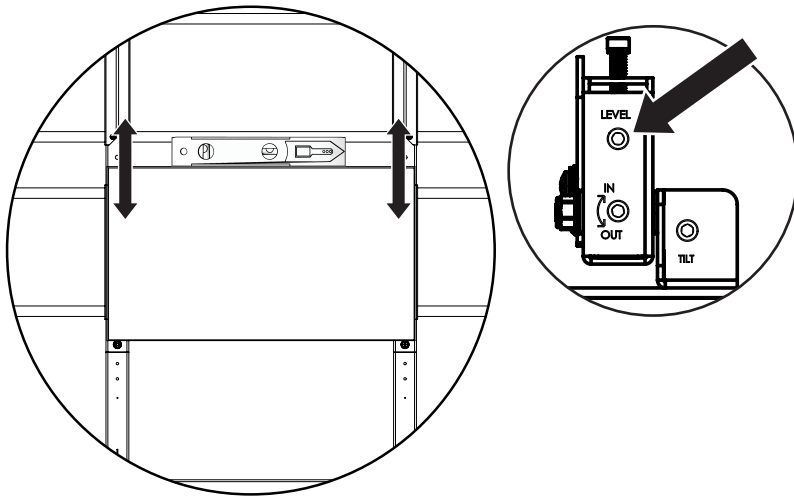

Step 6

With your level in hand, first place the level on top of the display bezel to set side to side level. Next, place the level on the face of the display to adjust top to bottom level of the display parallel to the frame. Once you have these steps confirmed, make sure the mounted display is center on the video wall frame left to right and tighten the security screws to secure the display to the round wall frames to further prevent side to side movement.

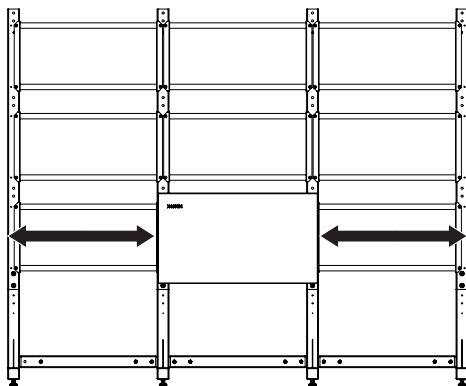

Next, follow the same steps for the lower left and right displays.

Once all three display are aligned and secured, the final fine adjustment of tilt and in/out can be used to insure all bezel edges are closely aligned. This will take a few adjustments back and forth to determine final screen adjustment.

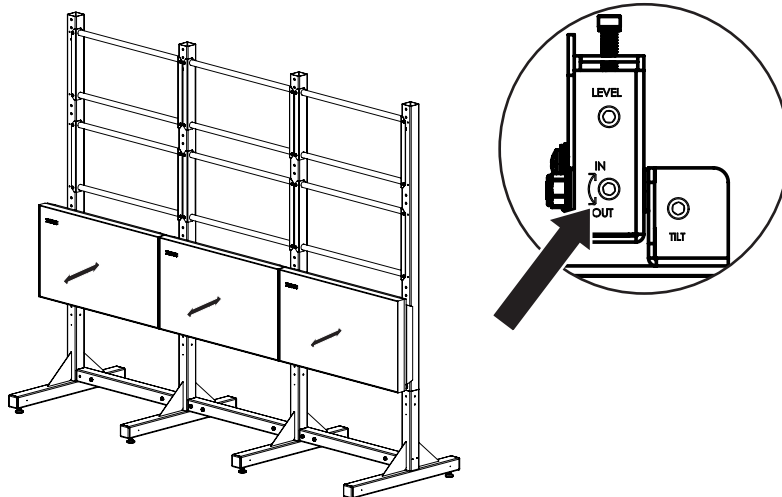

With the lower two or three display properly aligned you can move up to the second row, following the same procedure as the first row.

It is important that the time be taken to maximize the first row alignment before moving up as you do not want to have to go back and forth between rows. If done correctly your bezel edges should match very closely top and bottom.

Step 7

As you are installing the second and possible third level of monitors to the frame, you want to insure there is proper minimal bezel edge clearance between the upper and lower display. Some models have sensitive materials incorporated in the top and bottom edges of their display that do not allow for resting the weights of the display on top of each other. Side to side clearance of bezel edges is equally as important for natural chassis expansion that occurs as the display come up to full operating temperatures. Without the minimal clearance allowance, the display would push against each other causing some potential distortion of the chassis alignment.

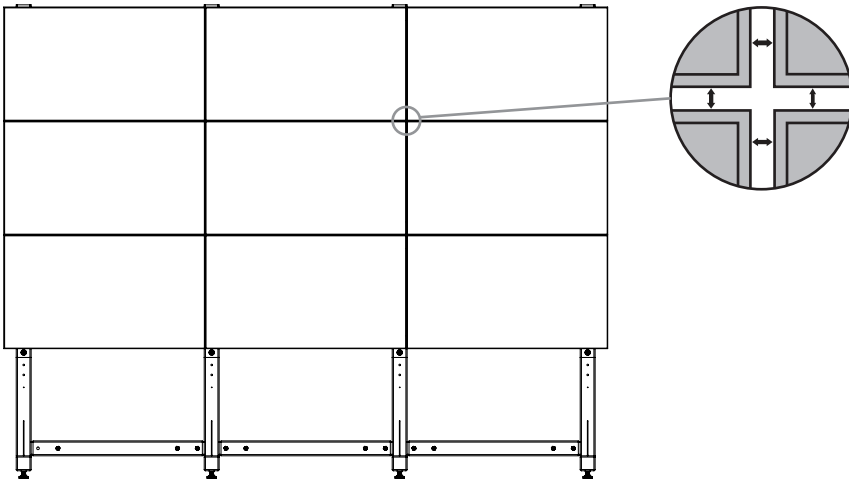

Note: A .05" gap between bezels is recommended for heat expansions.

Use a standard business card fold in half to double its thickness and use this to set your minimum clearance between display; not only top to bottom, but also side to side for better over all symmetry for the finished video wall. The business card should slide with ease the total length of the bezel edge. If not, adjust the clearance to allow for smooth movement of the card. This should be done at each level of monitors being installed before moving up to the next row of monitors. Use the bracket upper level screws to set the upper and lower bezel edge clearance, and the side to side security screw to adjust the side clearance.

