

# REELY

Ⓒ Operating Instructions

**Electro-Quadrocopter “Q Pro FPV” RtF**

Item No. 1526043

CE

# Table of Contents



	Page
1. Introduction .....	4
2. Explanation of Symbols .....	4
3. Intended Use .....	5
4. Product Description .....	5
5. Scope of Delivery .....	6
6. Safety Notes .....	7
a) General .....	7
b) Before Commissioning .....	7
c) During Operation .....	8
7. Battery and Rechargeable Battery Notes .....	9
a) Transmitter .....	9
b) Flight Battery .....	9
8. Start Preparations .....	10
a) Inserting the Batteries in the Transmitter .....	10
b) Charge Flight Battery .....	11
9. Operating Elements of the Transmitter .....	12
10. Safety Devices .....	13
a) Transmitter .....	13
b) Model .....	13
11. Information for First Take-Off .....	14
a) Mode 1 / Mode 2 .....	14
b) Hover Flight .....	14
c) Yaw Function .....	15
d) Nod Function .....	15
e) Roll Function .....	16
f) Flight Mode .....	16
12. The First Start .....	17
a) Start .....	17
b) Automatic Starting and Landing by Pushing a Button .....	18
c) Flight Movements .....	19
d) Flip Function .....	19

	<b>Page</b>
13. FPV Operation .....	20
a) General Information.....	20
b) Loading the App.....	20
c) Make the Model Ready to Start .....	21
d) Operation with the App .....	23
e) Viewing Pictures or Videos .....	23
f) Operating the Quadcopter with your Smartphone.....	23
g) Control Using the Position Sensors of your Smartphone .....	27
14. Maintenance and Repair.....	28
a) Regular Cleaning.....	28
b) Replacing the Rotors .....	28
c) Calibration with the Transmitter .....	29
15. Disposal .....	30
a) Product .....	30
b) Batteries/Rechargeable Batteries .....	30
16. Declaration of Conformity (DOC).....	30
17. Technical Data .....	31
a) Transmitter.....	31
b) Quadcopter.....	31
c) USB Charger .....	31

# 1. Introduction

---

Dear Customer,

thank you for purchasing this product.

This product complies with the statutory national and European requirements.

To maintain this status and to ensure safe operation, you as the user must observe these operating instructions!



These operating instructions are part of this product. They contain important notes on commissioning and handling. Also consider this if you pass on the product to any third party. Therefore, retain these operating instructions for reference!

All company names and product names are trademarks of their respective owners. All rights reserved.

If there are any technical questions, please contact:

International: [www.conrad.com/contact](http://www.conrad.com/contact)

United Kingdom: [www.conrad-electronic.co.uk/contact](http://www.conrad-electronic.co.uk/contact)

## 2. Explanation of Symbols

---



The exclamation mark in a triangle indicates important notes in these operating instructions that must be observed strictly.



The arrow symbol indicates that special advice and notes on operation are provided.

### 3. Intended Use

---

The electrical quadcopter "Q Pro FPV" is a helicopter-like model solely designed for private use in the model making area and the operating times associated with this.

This system is not suitable for other types of use. Any use other than that described above can damage the product and involves additional risks such as short circuit, fire, electric shock, etc. The safety information must be observed at all times!

The product must not get damp or wet.

This product is not a toy and not suitable for children under 14 years of age.

→ Observe all safety information in these operating instructions. They contain important information on handling of the product.

You are solely responsible for safe operation of the model!

### 4. Product Description

---

The quadcopter "Q Pro FPV" is a pre-assembled helicopter-like flight model with four rotors and an integrated camera. The control is possible in mode 1 and mode 2 equally. In the professional field, such flight devices are already used for the most diverse of tasks.

State-of-the-art microprocessor-controlled electronics with position control and acceleration sensors stabilise the flight position and flying altitude of the quadcopter "Q Pro FPV". Live transmission using the camera installed in the quadcopter permits "FPV-operation" (FPV = First Person View). Control only via a Smartphone is intended as well.

High-quality direct current engines in connection with a specially developed control permit a powerful flight operation. The new control and electronic self-stabilisation lead to great flight properties.

The product is intended for operation in closed rooms but may also be used outdoors in wind still conditions. The in-built electronic controls (integrated 6-axis gyro) can balance out small undesired changes to the flight altitude, but cannot remove them completely. As the "Q Pro FPV" quadcopter weighs approx. 19 g, it reacts sensitively to wind or draughts.

## 5. Scope of Delivery

---

- Pre-installed quadcopter "Q Pro FPV"
- Transmitter
- Smartphone holder for transmitter
- USB charger
- Two spare rotors (front)
- Two spare rotors (rear)
- Operating instructions

### Current operating instructions

Download the current operating instructions via the link [www.conrad.com/downloads](http://www.conrad.com/downloads) or scan the QR code displayed. Observe the instructions on the website.



→ The spare part list can be found on our website [www.conrad.com](http://www.conrad.com) in the download section for the respective product. Alternatively, you may also email to request the list of spare parts. For contact information, see the chapter "Introduction" at the beginning of these operating instructions.

# 6. Safety Notes

---



In case of damage caused by non-compliance with these operating instructions, the warranty/guarantee will expire. We do not assume any liability for consequential damage!

We do not assume any liability for property damage or personal injury caused by improper use or non-compliance with the safety instructions! In such cases the warranty/guarantee is voided.

Normal wear and tear and accident and crash damage (e.g. broken rotor blades or chassis parts) are also excluded from the guarantee and warranty.

Dear Customer,

this safety information serves not only to protect the product, but also your own safety and the safety of other persons. Therefore, read this chapter very carefully before taking the product into operation!

## a) General

Caution, important note!

Operating the model may cause damage to property and/or individuals.

Therefore, make sure that you are sufficiently insured when using the model, e.g. by taking out private liability insurance. If you already have private liability insurance, verify whether or not operation of the model is covered by your insurance before commissioning your model.

Observe: In some EU countries, you are required to have insurance for any flying models!

- The unauthorized conversion and/or modification of the product or its components is inadmissible for safety and approval reasons.
- This product is not a toy and not suitable for children under 14 years of age.
- The product must not get damp or wet.
- Do not leave any packaging material unattended. It may become a dangerous playing material for children.
- Should questions arise that are not answered by these operating instructions, contact us (for contact information, see chapter 1) or another expert.

## b) Before Commissioning

- Make sure that no other models are operated within the range of the remote control on the same 2.4 GHz band (transmitter frequency). Always check if concurrently operated 2.4 GHz transmission systems interfere with your model.
- Regularly check the functional safety of your model and of the remote control system. Watch out for any visible damage such as damaged mechanics (e.g. rotors).
- All moving parts on the model must run smoothly but must not have any tolerance in the bearing.
- Check before each operation the correct and secure position of the rotors.
- The flight battery required for operation must be charged according to these operating instructions.



- Ensure sufficient residual capacity (battery tester) of the batteries inserted in the transmitter. If the batteries are empty, always replace the complete set, never individual cells only.
- When the rotors are running, make sure that neither objects nor body parts are in the rotating and suction area of the rotors.

### **c) During Operation**

- Do not take any risks when operating the model! Your own safety and that of your environment depends completely on your responsible use of the model.
- Improper operation can cause serious damage to people and property! Therefore make sure to keep a sufficiently safe distance from persons, animals or objects during operation.
- Select an appropriate location for the operation of your model.
- Fly your model only if your ability to respond is unrestricted. The influence of tiredness, alcohol or medication can cause incorrect responses.
- Do not direct your model towards spectators or towards yourself.
- Motor, electronics and flight battery may heat up during operation of the model. For this reason, take a break of 5 to 10 minutes before recharging the firmly integrated flight battery in the quadcopter.
- Never switch off the remote control (transmitter) while the model is in use. After landing, always first switch the on/off switch at the quadcopter to the "off" position ("OFF"). Only then may the remote control transmitter be switched off.
- In case of a defect or a malfunction, remove the problem before using the model again.
- Never expose your model or the remote control to direct sunlight or excessive heat for an extended period of time.
- In the case of a severe crash (e.g. from a high altitude). The electric gyro sensors can be damaged. Therefore, full functionality must be tested before flying again without fail!
- Switch off the rotor motors at once after a crash. Rotating rotors may be damaged if they come into contact with obstacles e.g. overcharging. Before flying again, these should be checked for possible tears or breakages!
- To avoid damage to the model through crashing due to low voltage or deep discharge of the rechargeable battery through total discharge, we recommend that you respect the low voltage light signals without fail.



# 7. Battery and Rechargeable Battery Notes

---



Although use of batteries and rechargeable batteries in everyday life is a matter of course today, there are many dangers and problems. In particular in LiPo/Lilon batteries with high energy content (as compared to conventional NiCd or NiMH batteries), various provisions must be complied with to avoid danger of explosion and fire.

The model is delivered with a firmly installed, non-replaceable rechargeable battery and a matching charger. Nevertheless, we are including extensive information on handling batteries for safety reasons. Should you use your own accessories, please ensure you follow all information enclosed by the respective manufacturer.

## a) Transmitter

- Keep batteries/rechargeable batteries out of the reach of children.
- Do not leave any batteries/rechargeable batteries lying around openly. There is a risk of batteries being swallowed by children or pets. If swallowed, consult a doctor immediately!
- Batteries/rechargeable batteries must never be short-circuited, disassembled or thrown into fire. There is a danger of explosion!
- Leaking or damaged batteries/rechargeable batteries can cause chemical burns to skin on contact; therefore, use suitable protective gloves.
- Do not recharge normal batteries. There is a risk of fire and explosion!
- Make sure that the polarity is correct when inserting the batteries (pay attention to plus/+ and minus/-).
- If the device is not used for an extended period of time (e.g. storage), remove the inserted batteries from the remote control to avoid damage from leaking batteries.
- Always replace the whole set of batteries. Do not mix full batteries with half-full ones. Always use batteries/rechargeable batteries of the same type and manufacturer.
- Never mix batteries and rechargeable batteries!

## b) Flight Battery

### Attention!

Leave the on-off switch of the quadcopter in the "off" position ("OFF") when you are not using the flight model (e.g. during transport or storage). Otherwise, the LiPo flight battery may be deep-discharged and is thus destroyed and rendered useless! There is also a danger of malfunction due to interferences. The rotors could start up inadvertently and cause damage or injury.

- Never charge the LiPo flight battery immediately after use. Always leave the LiPo flight battery to cool off first (at least 5 - 10 minutes).
- Charge the LiPo flight battery firmly installed in the quadcopter only via the enclosed USB-LiPo-charger.
- Only charge intact and undamaged batteries. If the outer isolation of the rechargeable battery is damaged or the battery is deformed or bloated, it must not be charged. In this case, there is immediate danger of fire and explosion!



- Place the model on a fire-resistant surface for charging (e.g. a plate). Keep a distance to flammable objects (use USB extension cable if required).
- As the charger and the rechargeable LiPo flight battery both heat up during the charging procedure, it is necessary to ensure sufficient ventilation. Never cover the charger or the quadcopter!
- Never leave LiPo batteries unattended while charging them.
- Remove the quadcopter from the charger when it is fully charged.
- The charger is intended for dry indoor use only. The charger and the quadcopter must not become damp or wet.
- There is the risk of fire or explosion by the rechargeable battery in case of error. LiPo batteries specifically react very strongly to moisture and oxygen due to the chemicals contained in them! Do not expose the charger or quadcopter to high/low temperatures or to direct solar radiation.

## 8. Start Preparations

---

### a) Inserting the Batteries in the Transmitter

Remove the battery compartment lid on the back of the transmitter. For this, you need to push the lid in the direction of the arrow (1).

Insert two micro/AAA size batteries with the correct polarity (2). Observe the corresponding icons in the battery compartment. Insert the battery compartment lid again (3).

→ Operation of the transmitter with batteries is not recommended because of the lower cell voltage (battery = 1.5V, rechargeable battery = 1.2V) and the self-discharge of rechargeable batteries. Quick feedback of the transmitter on low charge status of the transmitter power supply would result.

Since the transmitter requires very little power, batteries will keep much longer. We recommend the use of high-quality alkaline batteries.

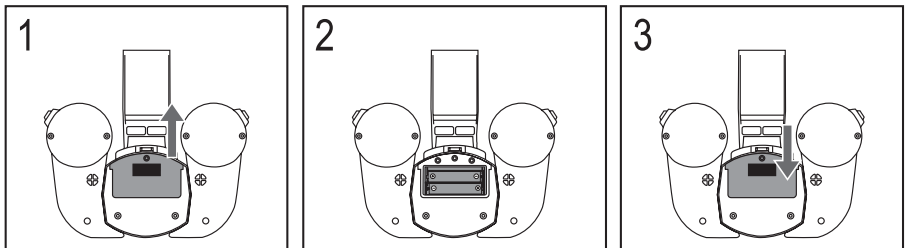

Figure 1

## b) Charge Flight Battery

A suitable USB mains unit or USB cigarette lighter adapter (neither enclosed) may be used for power supply to the enclosed USB charger; they each must have an output current of at least 500 mA.

Alternatively, the USB port of a computer or USB hub with a dedicated mains unit can be used as well that can supply a current of 500 mA per port.

Connect the USB charger from the delivery to the USB power supply with its USB plug (1) (as described above, e.g. a USB mains unit or similar). Then connect the small plug (2) of the USB charger to the corresponding socket of the quadrocopter (3). Observe proper alignment of the plug (the plug contour must match the socket in the quadrocopter).

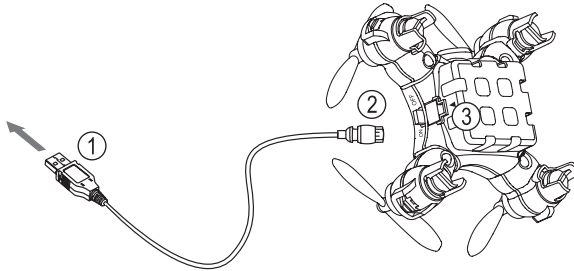

Figure 2

If the battery is not defective (high-Ohmic/interrupted) and power supply is warranted, charging commences. This is signalled by the red LED in the USB charger.

The following LED displays are possible:

LED is permanently lit: The battery is being charged

LED is off: The battery is full or fully charged

## 9. Operating Elements of the Transmitter

---

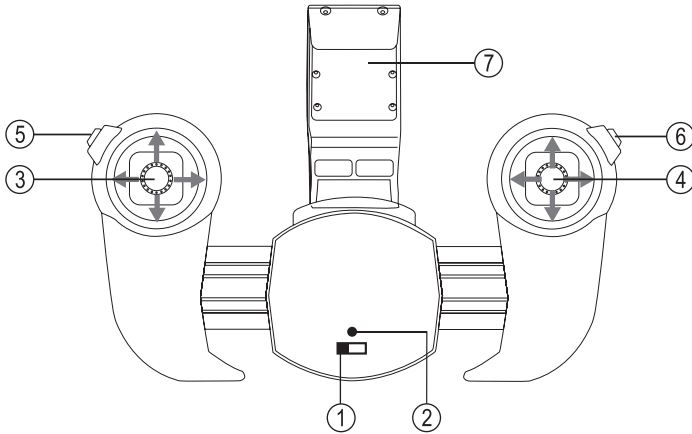

Figure 3

- 1 On/off switch
- 2 LED for function control
- 3 Left control lever (motor speed and yaw in mode 2)
- 4 Right control lever (roll and nod in mode 2)
- 5 Switch mode 1 / mode 2
- 6 Automatic start / landing
- 7 Smartphone holder

→ Figure 3 shows the Smartphone holder already installed. The two operating elements of the transmitter are already pushed outwards here. This is only necessary if you want to put a Smartphone into the holder.

The holder is installed from above by pushing the holder into the holder provided in the transmitter.

# 10. Safety Devices

---

→ The quadcopter "Q Pro FPV" has a range of safety devices in the transmitter and flight model which protect the model from damage and/or should reduce possible damage to a minimum. The protection mechanisms are identified by LED indicators (flight model) or an acoustic warning signal (transmitter).

## a) Transmitter

The battery condition is continually inspected while the transmitter is in operation. If the voltage level of the batteries drops below a certain value, the transmitter will signal this with an intermittent warning sound and permanent flashing of the LED at the transmitter (figure 3, item 2). In this case, stop flying at once and replace the batteries of the transmitter.

## b) Model

The LEDs in the quadcopter (in the landing struts) show if the transmitter is "bound" to the model and reception of the transmitter signal is proper. This is displayed by permanently lit LEDs. When the LEDs flash, the quadcopter does not correctly receive the transmitter signal. In this case, "binding" must be performed again.

The quadcopter constantly monitors the voltage of the integrated flight battery. Should this fall below a critical level during a particular period, this will be indicated by the flashing LEDs.

If the voltage undercut is permanently below a specific value, an emergency landing is initiated after a brief time and the motors are switched off.

→ If the undervoltage is displayed at the quadcopter by flashing of the LEDs, only approx. 20 to 30 seconds of flight time remain to independently return the model to the starting point and land it.

If a certain voltage level of the flight battery is reached, the motor control will be switched off by the transmitter and automatic landing is initiated. This process cannot be influenced by the transmitter anymore.



If the model is above a body of water, tree, house, street, persons, animals, etc. at the time and/or if the model is flying more than 1 metre above ground, the model may be damaged or lost and there may be property damage and injury to persons/animals nearby.

# 11. Information for First Take-Off

---

## a) Mode 1 / Mode 2

The remote control mode specifies which control function is executed with which control element at the transmitter. The remote control transmitter is configured to mode 2 after activation. However, you can also switch to mode 1.

—> The explanations on the control functions in mode 2 are presented in these operating instructions.

The difference between mode 1 and mode 2 is in that the motor control function is transferred from the left control lever to the right control lever when switching from mode 2 to mode 1. The nod control function of the right control lever switches to the left control lever at the same time. The functions (e.g. forward / backward = nod; climb / drop = motor control) do not change. The function "Flight mode" remains on the left control lever and the function "Flip" on the right control lever in mode 1 as well.

If you want to control your quadcopter in mode 1, you need to push the left switch (figure 3, item 5) at the top of the transmitter before operating the model and switch on the transmitter while you keep the button pushed. The setting "Mode 1" is reset to mode 2 after the transmitter is switched off.

## b) Hover Flight

—> For a simpler and consistent explanation of steering, classic terminology is used here as well. This comes from flight language and is widely used.

Directional descriptions are always to be interpreted from the perspective of a "virtual" pilot in the model. The two black rotors are considered direction indicators. They mean "front". The explanations are all based on configuration of the remote control to mode 2 (basic position after activation).

Hovering denotes a flight status in which the quadcopter neither rises nor falls so that the upwards directed uplift force is equal to the downwards directed weight.

Push the throttle lever (figure 3, item 3) forward to increase the motor speed and lift up the quadcopter. Pulling the throttle lever back causes the quadcopter to drop. If you leave the throttle lever in the middle position, the quadcopter will try to maintain the height via the integrated sensors.

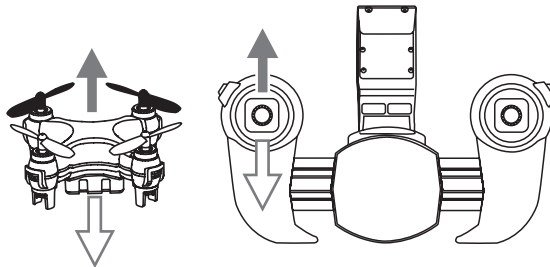

Figure 4

—> During flight close above the ground and during take-off, turbulence and air flow can be experienced which may affect the quadcopter. A quicker response to the controlling motions and slight swerving of the quadcopter forwards, backwards or to the side may result from this. This so-called ground effect is no longer present starting at a flight height of about 50 cm.

### c) Yaw Function

"Yaw" denotes the rotation of the quadcopter around the yaw axis (vertical axis). This movement either occurs unintentionally due to the speed torque of the rotors or intentionally as a flight direction change. This movement is caused by speed changes of the individual rotors towards each other in the quadcopter.

If you move the left control lever to the left, the quadcopter will turn to the left. If you move the control lever to the right, the quadcopter will turn to the right.

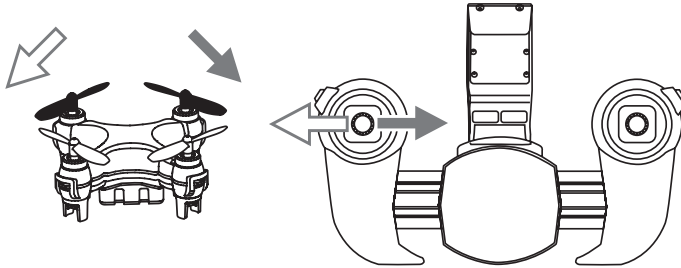

Figure 5

### d) Nod Function

"Nod" denotes the movement around the cross axis which can be compared to the nodding of a head. Through this, the quadcopter gains flight speed forwards or backwards or decelerates.

If you move the right control lever to the front, the quadcopter will float forwards as a whole. If you move the control lever to the rear, the quadcopter will float backwards.

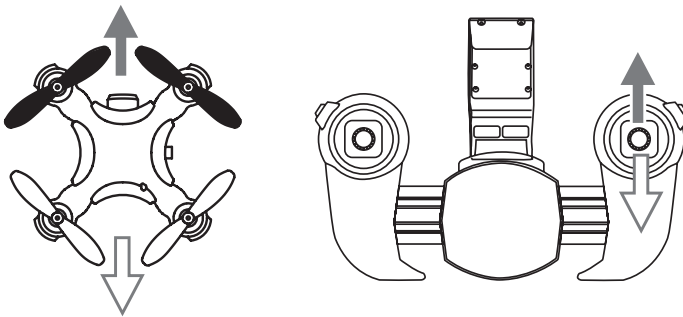

Figure 6

## e) Roll Function

"Roll" denotes the movement around the centre line which can be compared to the sideways rolling of a ball (or the sideways crawl of a crab). In this way, through lifting one side the quadrocopter moves independent of its forward direction to the side.

If you move the right control lever to the left, the quadrocopter will float to the left as a whole. If you move the control lever to the right, the quadrocopter will float to the right.

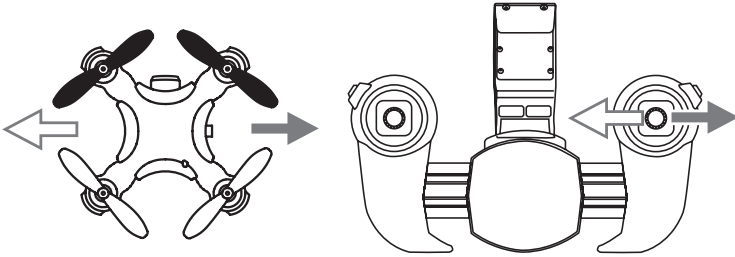

Figure 7

## f) Flight Mode

The quadrocopter permits you to choose between three different flight modes depending on your experience.

Change the flight mode by briefly pushing the left control lever at the transmitter (see figure 8) (push the control lever like a conventional button).

In beginner mode, the control commands are limited to permit you learning how to fly the quadrocopter very quickly and easily. This flight mode is recommended for pilots who have no or only very little flight experience with helicopters or quadrocopters yet. The beginner's mode is the basic configuration after switching the transmitter on each time.

The advanced mode is recommended to pilots who have already collected some experience with other quadrocopter models. In this mode, the quadrocopter is much more agile in its control conduct than in beginner's mode. In order to activate this mode, push the left control lever at the transmitter (figure 8) briefly repeatedly until you hear a double sound.

The professional mode is recommended to pilots who have already collected a lot of experience with other quadrocopter models. In this mode, the quadrocopter is even more agile in its control conduct than in advanced mode. In order to activate professional mode, push the left control lever at the transmitter (figure 8) briefly repeatedly until you hear a triple sound.

Pushing the left control lever again will return you to beginner's mode. This is signalled by a single control sound.

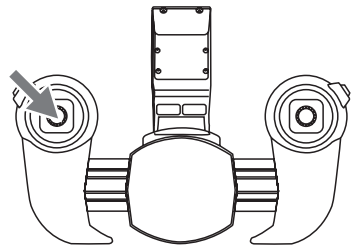

Figure 8



## 12. The First Start

---

### a) Start



The operation and handling of remote controlled flight models must be learned! If you have never steered such a model, start especially carefully and get used to the reactions of the model to the remote control commands first. Do be patient! Use the information from chapter 11 as reference.

Do not take any risks when operating the product! Your own safety and that of your environment depends completely on your responsible use of the model.

- Switch on the quadcopter. The LEDs in the model start to flash quickly.
- Place the model on a level surface as smooth as possible (e.g. stone floor). A carpet is less suitable because the landing legs may get caught in the carpet easily. The front (black) rotors point forward (away from you).
- Switch off the remote control transmitter by pushing the on/off switch. The transmitter confirms this with a signal sound. The control LED at the transmitter flashes.
- Push the left control lever forward until a control sound sounds.
- Pull the left control lever backwards until a control sound sounds. The control LED at the transmitter and the LEDs at the quadcopter are now permanently lit. Put the left control lever into the neutral position again.
- The quadcopter is now bound to the transmitter and ready to start.
- Start the rotors by putting both control levers as shown in figure 9. The rotors start up.
- Now, put both control levers into the neutral position. Pull and hold both control levers to the position that you used for starting the rotors (see figure 9) for approx. two seconds to switch off the rotors again.
- Now increase the rotating speed of quadcopter rotors by pushing the left control lever forward slowly until the quadcopter takes off and hovers in front of you at a height of approx. 1.5 metres.

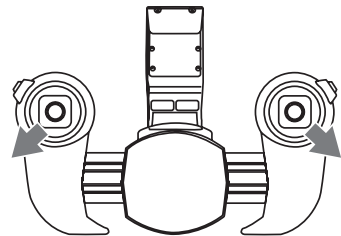

Figure 9

Generally avoid any fast and big controlling motions. Also watch closely to see whether and in which direction the quadcopter moves in the "Roll" function (also sideways).

- To land the quadcopter again, pull the left control lever back slightly in a suitable landing location until the quadcopter gravitates to the ground. A somewhat solid touchdown on the ground is no problem and should not be corrected with jerky throttle movements. When landing, both rotors are switched off automatically when the model has reached the ground.
- Try to touch down where possible in vertical position ("helicopter landing"). Avoid landing with high horizontal speeds ("airplane landing"). If you have not done so yet, switch off the motors after landing (see figure 9).
- Practice this starting procedure a few times to get a feel for the quadcopter. Once you are reasonably sure, you can begin to steer the flight direction with yaw, nod and roll functions (see notes in chapter 11). Always steer slowly and carefully and practice the processes a little before trying a new flight manoeuvre. The first flights should not last longer than 30 to 60 seconds respectively.

- When you have familiarised yourself a little with the model's flight properties, you may perform additional exercises. Start with simple flight manoeuvres like a flying a meter forwards/back (nod function). Then practice hovering to the left/right (roll function). When you have the practice you need, start flying circles and figure eights.
- If you want to terminate flying, the rotors must be switched off first after landing. Then put the model's on/off switch to the "OFF" position. Only then must the transmitter be switched off.

## b) Automatic Starting and Landing by Pushing a Button



### Attention!

Automatic starting of the model requires an accessible starting position in all directions. This function therefore can only be used in large rooms/halls or outdoors. Persons and objects must be at least 5 metres away from the starting position. When not observing this, there is a danger of damage to the model or other objects nearby and a danger of injury to persons/animals in the vicinity!

Automatic landing is a firmly programmed process. The prerequisite for safe automated landing is that the model is in a stable flight condition (hovering) before the respective operating button is pushed at the transmitter, the flight height ideally does not exceed 1.5 metres and the landing point is at least 5 metres away from obstacles and persons.

When not observing this, there is a danger of damage to the model or other objects nearby and a danger of injury to persons/animals in the vicinity!

The model can be started and landed by pushing a button. For this, put the ready-to-start quadcopter onto a level surface at a sufficient distance from the pilot (see notes above). To start, simply push the corresponding button at the transmitter (see figure 10, item 1). The rotors at the model will start up at once, and the quadcopter will rise vertically up to hover before you at approx. 1.5 - 2 metres height. Now you can perform flight operation by the corresponding control movements at the transmitter.

For landing, find a suitable landing place (see notes above), put the model into stable hover flight and to a flight altitude of ideally max. 1.5 metres. Now push the corresponding button (see figure 10, item 2). The model will initiate landing right after this, reduce height vertically and switch off the rotors on the ground.

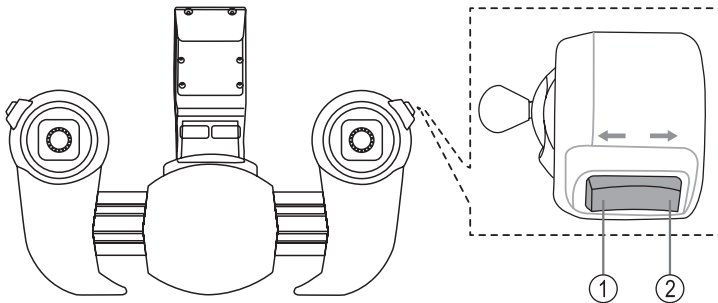

Figure 10

## c) Flight Movements

After the model has been started, it is in hover flight. Push the left control lever at the transmitter forward carefully. This initiates rising of the model. Put the left control lever into the middle position again to stop rising. Pull the left control lever back carefully to start sinking. Put the left control lever into the middle position again to stop sinking.

If you move the left control lever to the left, the model will turn around its vertical axis. If you move it towards the right, the quadcopter will turn to the right.

Push the right control lever forward carefully. The model is controlled forward. If you push the right control lever backwards, the quadcopter will be controlled backwards.

If the right control lever is controlled to the left, the model will float to the left. If you move the right control lever to the right, the quadcopter will float to the right.

→ When controlling the model, also observe the notes in chapter 11.

## d) Flip Function

The model can perform a flip (a 360° turn). For this, put the quadcopter into a stable hover flight at an altitude of at least 1.5 metres at sufficient distance from the pilot and any obstacles.

Now push the right control lever (figure 11); push the control lever like a conventional button.

The transmitter will emit a control sound at an even rhythm to confirm that you have chosen flip mode. The control sound will remain activated until the flip is completed.

Now, briefly put the right control lever in the direction in which the flip is to take place.

Examples: If you push the right control lever forward, the quadcopter will turn over forwards. If you push the right control lever backward, the quadcopter will turn over to the right.

After you have specified the flip direction at the transmitter, put the right control lever into the neutral position again at once.

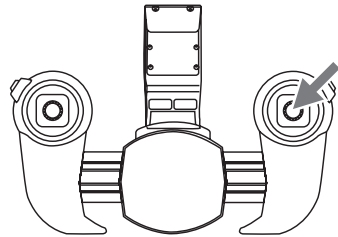

Figure 11

### Attention!

The flip function generally must only be used if the model is flown in a large hall/in a large room or outdoors, is in a stable flight condition (hovering) before the respective operating button is pushed at the transmitter, the flight height is not below 1.5 metres and the quadcopter is at least 5 metres away from obstacles and persons. If this is not observed, there is a danger of damage to the model or other objects nearby and a danger of injury to persons/animals in the vicinity from contact or crash!

→ When the model is already in "Low Batt mode" (LEDs at the quadcopter flash), the flip function is deactivated for reasons of safety and therefore cannot be performed.

The model can perform a flip function only in one direction (only forward or backward; only to the left or right) and therefore also requires the corresponding clear control commands from the transmitter (right control lever forward or back; right control lever to the left or right). Therefore, avoid inadmissible control commands when the flip function is activated, such as "right control lever pushed to the front+left". In such cases, there may be uncontrolled flight conditions and crashes.

After a flip, the function is automatically deactivated at the transmitter. If you want to perform another flip, you need to activate the flip function at the transmitter first.

# 13. FPV Operation

---

## a) General Information

The quadcopter is serially equipped with a camera that transmits a video to a suitable Smartphone (not enclosed) live by radio. Recording of pictures and control of the camera are possible by an app installed on the Smartphone. Pictures or videos can be saved on the Smartphone and processed further from there. The live transmission permits "FPV-operation" (FPV = First Person View).



### Attention!

Pure FPV operation poses danger of accidents, since you may not see obstacles or not see them in time due to the limited camera image. Therefore, FPV operation generally must be observed by a co-pilot who can warn of dangers in time. It also requires a lot of practice to fly in FPV operation. Also observe specifically during the learning phase that the chosen flight field is free of obstacles and far from people, animals, buildings and streets.

For interference-free transmission of the video signals, no other transmitters must be present in the 2.4 GHz transmission range of the model. The "Bluetooth®" function in the Smartphone must be deactivated.

Do not violate the privacy of others when recording pictures and videos. You must only make recordings for your personal use. Publications of any kind may require consent of the owner or the persons shown in the image. In any case, observe the laws of your country.

## b) Loading the App

FPV operation requires that you first install a special app on your Smartphone. Only those costs that usually arise from a download will be incurred for this. The app as such is free of charge.

Scan one of the following QR codes depending on your Smartphone's operating system (iOS or Android). Scanning will automatically take you to the current version of the app. Alternatively, you can find the app "CX-10WIFI" for the operating system iOS in the "Apple Store" and in the "Google Play Store" for the operating system Android.



iOS



Android

Figure 12

### c) Make the Model Ready to Start

Make your quadcopter ready for operation by binding the quadcopter with the activated transmitter. The model will now emit a transmission signal.

Activate the "WiFi function" in your Smartphone under "Settings". Then connect the "CX-10WIFI" App to the quadcopter in order to connect the model to your Smartphone. Now start the App. The starting screen (figure 13) appears.

#### Function of the app

Figure 13 shows the home page of the app. There are three options there:

- 1 Question mark symbol = Call the help menu
- 2 Gear symbol = Make settings
- 3 Symbol "play" = Start App



Figure 13

#### Question mark symbol (1)

If you select this, you will see a new view in which you will find the corresponding notes on operation in English. They can help you if you do not have your operating instructions at hand. To leave the help function, select the symbol at the upper left. You will be returned to the main menu (figure 13).

#### Gear symbol (2)

If you have chosen this symbol, you will see a new view in which you can set the following function:

- **"Parameters auto save":**  
Automatic storage of pictures and videos (recommended)
- **"Reverse control screen by gravity sensing":**  
Turn the display on the Smartphone depending on position of the display (recommended).
- **"Right hand mode":**  
With this function, you can switch the control from mode 2 to mode 1. Observe the notes in chapter 11 for the differences between mode 1 and mode 2.
- **"720P preview":**  
This function is not planned for this model and will not work.

To leave the setting function, select the symbol at the upper left. You will be returned to the main menu (figure 13).

- Symbol "play" (3)

Select "play" (3) to open the following operating interface:

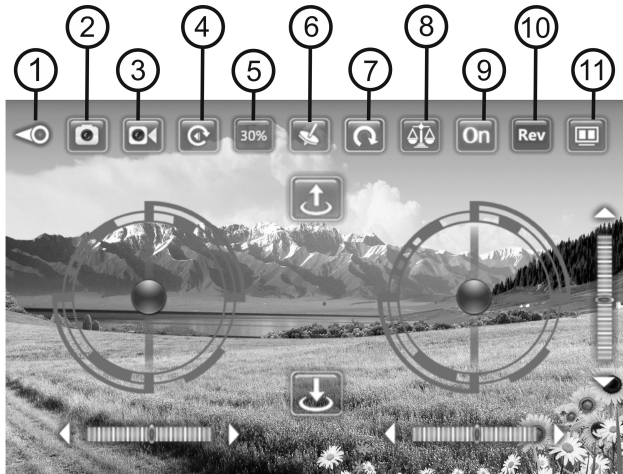

Figure 14

The symbols shown in the upper row (1 - 11) have the following functions:

- 1 Leaving the screen
- 2 Taking pictures with the quadcopter camera
- 3 Recording video with the quadcopter camera
- 4 Viewing stored pictures or videos
- 5 Flight mode (beginner / advanced user / pro)
- 6 "Gravity sensor mode" (controlling the model with the position sensors of your Smartphone)
- 7 Flip (the model performs one flip)
- 8 Calibration (calibrates the sensors in the quadcopter)
- 9 Show/hide control elements (shown = control with the Smartphone; hidden= control with the remote control transmitter)
- 10 Turning screen contents (only when the automatic turning of the screen content is deactivated in the settings via the gear symbol (see figure 13, item 2))
- 11 Settings for 3D-Livefigure view (only possible with special "VR glasses")

## d) Operation with the App

When the quadcopter is ready to start (see preceding chapter c) and the App is activated in your Smartphone with "Play" (see figure 13, item 3), you will receive a live image from the quadcopter camera. You can start at once and – if desired – fly the quadcopter in FPV mode using the camera images.

→ "Binding" the two devices is successful if the LEDs in the quadcopter's landing struts remain lit and the LED on the bottom of the housing of the model flashes. The display now shows the operating elements of the App and the video image of the camera installed in the model. Choose "On" (see figure 14, item 9), in order to conceal the control elements.

Additionally, you can take a picture with the quadcopter camera or start a video recording with the video camera symbol (figure 14, item 3) on the display of your Smartphone before or during operation of the quadcopter by selecting the camera symbol (see figure 14, item 2).

→ You cannot use the app to take serial pictures. The camera is activated when you touch the camera icon (figure 14, item 2). A picture will be created after releasing the symbol. Stop video recording by selecting the video camera icon (figure 14, item 3) again.

## e) Viewing Pictures or Videos

When you have stopped flying, you can view the first pictures or videos on your Smartphone right away. For this, choose the corresponding symbol on your Smartphone (figure 14, item 4). New screen content will appear.

Select either "Pictures" or "Video". Depending on your selection, another screen content will appear with the saved pictures or videos. You can open them for viewing by tapping them. To delete pictures or videos, select the corresponding file (touch it for a longer time) and then following the screen instructions.

## f) Operating the Quadcopter with your Smartphone

→ The quadcopter "Q Pro FPV" can be operated with your Smartphone alone rather than via the enclosed transmitter as well. There are two options that will be described below. The function descriptions are presented and explained in mode 2. When switching to mode 1, observe the notes in chapters 11 and 13 as well.

Just as when using the remote control transmitter, you can also record pictures and videos when using your Smartphone for operation.



For interference-free transmission of the control and video signals, no other transmitters must be present in the 2.4 GHz transmission range of the model. The "Bluetooth®" function in the Smartphone must be deactivated.

Do not violate the privacy of others when recording pictures and videos. You must only make recordings for your personal use. Publications of any kind may require consent of the owner or the persons shown in the image. In any case, observe the laws of your country.

The model will react a little more slowly to the control commands of your Smartphone and – because it is not the usual – not quite as precisely as when controlled with the remote control transmitter. Therefore, ensure that your flight area has no obstacles. Be patient when controlling your model with a Smartphone.

## Control with the Operating Elements of the App

After starting the App, various operating elements will be displayed on your Smartphone in addition to the camera image. In addition to the operating elements for the camera that you already know (see chapter 13, items 1 - 4), the control elements of a remote control transmitter as well as a symbol for automatic start and automatic landing are "symbolically" displayed (figure 15, items 12 - 18).

The left control element (12) controls elevation as well as turning around the vertical axis, as on the remote control transmitter. The right control element (13) controls the "nod" and "roll" functions. The symbol for "Auto start" (14) and "Auto landing" (15) is shown between the two control elements.

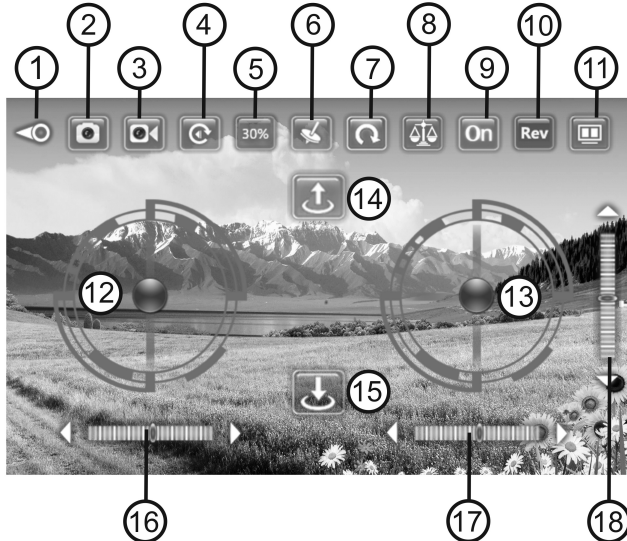

Figure 15 (description of the symbols 1 - 11, see figure 14)

If you want to control the model with your Smartphone and the operating elements in the App, proceed as follows:

- Switch on the quadcopter. The LEDs in the landing struts flash. The model will now emit a transmission signal.
- Switch on your Smartphone. Connect your Smartphone to the "CX-10WIFI" signal in "Settings / WIFI".
- Now activate the App "CX-10WIFI" on your Smartphone.
- Select "play". The quadcopter and your Smartphone are now "bound".
- "Binding" the two devices is successful when the LEDs in the quadcopter's landing struts remain lit and the LED on the bottom of the housing of the model flashes. The Smartphone display now shows the operating elements of the App and the video image of the camera installed in the model.
- Put the quadcopter in a suitable starting location for starting. Also observe the notes in chapters 11 and 12. Now select the symbol "Auto-Start" (14). The rotors will start and the model will lift off of the ground and hover in front of you at a height of approx. 1.5 metres.



→ The two control elements (figure 15, items 12 + 13) in your display represent the control levers of a remote control transmitter and can be controlled in the same manner. Hold the Smartphone with both hands. Touch either "point" with one finger each (best with your thumbs) and control the model as explained for controlling it with a remote control transmitter in chapters 11 and 12.

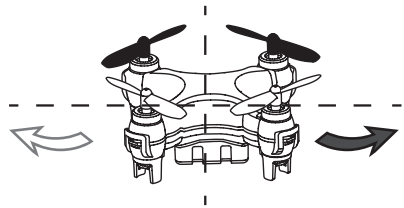
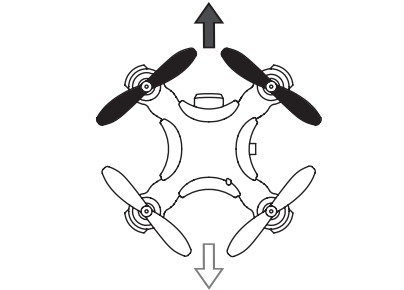
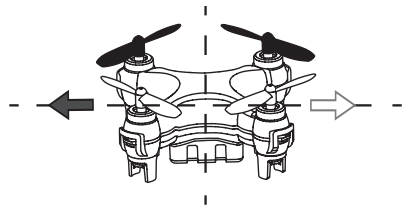
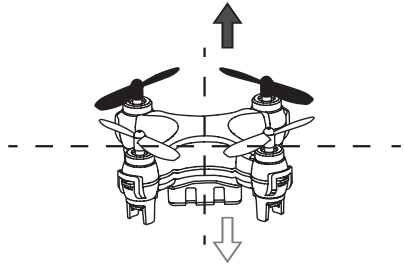

Figure 16

In the basic configuration, the App is set to "30%" (figure 15, item 5). This corresponds to beginner's mode (also see chapter 11). The control functions are limited in their effects.

If you touch this symbol again, "60%" will appear. This corresponds to advanced mode. The model reacts more agile to the control commands.

If you touch the symbol again, "100%" will appear. This corresponds to professional mode. The control functions are not limited then. If you touch the symbol again, the display will return back to "30%" and beginner's mode will be activated.

If the model drifts in flight, you can fix this drift with the respective trim element. If, for example, the model turns around its own axis to the left, push the trim element for "yaw" (16) and trim to the right until the model stops rotating.

If the model drifts, e.g., to the left, use the trim element for "Roll" (17) and trim to the right until the model stops drifting to the left. A drift of the control function "Nod" can be fixed with the respective trim element (18).

→ If the options of the trim elements are not sufficient to make the model fly stably or if it is flying differently from what you are used to, you need to re-calibrate the sensors of your quadcopter. For this, put the quadcopter onto a level surface ready to start. Push the icon for calibration (8). The LEDs in the landing legs start to flash. Calibration is successfully completed when the LEDs are lit permanently again.

Pushing the arrow (figure 15, item 7) can make the model do a flip (a 360° turn). For this, put the quadcopter into a stable hover flight at an altitude of at least 1.5 metres at sufficient distance from the pilot and any obstacles. Select the arrow symbol (figure 15, item 7). Then move the right control element forward/back/to the left or right (one direction only!). The model will now flip in that direction. This function works according to the function on the remote control transmitter. Therefore, observe the notes in chapter 12 as well when using this function.

### g) Control Using the Position Sensors of your Smartphone

Smartphones have position sensors, e.g. to turn the display to make the contents legible or recognisable no matter how you hold your device. The quadcopter can be controlled using these sensors in the control functions "nod" (forward and backward) and "roll" (to the left and right).

In order to control your model with the position sensor, you first need to make all the starting preparations described in chapter "Control with the Operating Elements of the App". When this has been successfully completed, push the radio tower icon (figure 15, item 6) until it lights up. Control via position sensors is now activated.

Hold the Smartphone horizontally in both hands. Last, push the "Auto-Start" symbol again (figure 15, item 14). The quadcopter will start up at once and float in front of you. Continue to control height and turn around the vertical axis with the left control element in the display (figure 15, item 12).

Floating to the left/right and forward/backward is no longer controlled with the right control element now, but via the position sensors in your Smartphone. Tip the Smartphone forward to make the model drift forward. Tip the Smartphone backward to stop the forward movement or make the model drift backward. Tip the Smartphone to the left to make the model drift left. The flight direction will be according to how you hold your Smartphone.

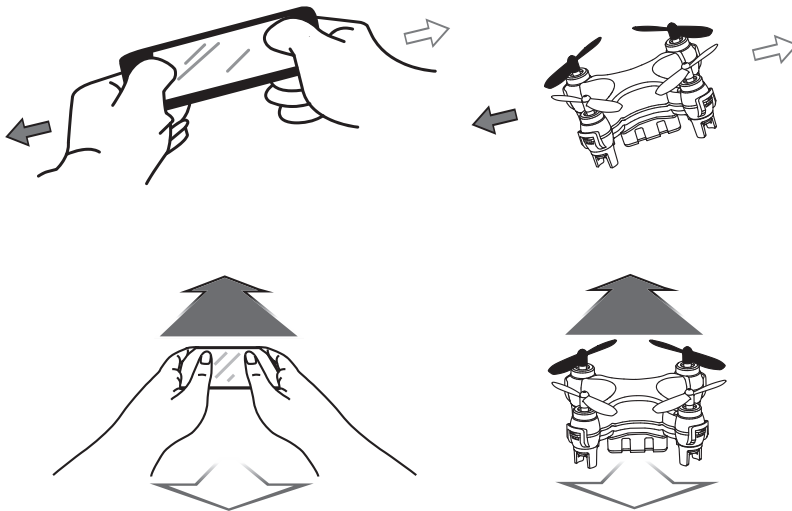

Figure 17

# 14. Maintenance and Repair

## a) Regular Cleaning

The quadcopter "Q Pro FPV" is a very simply built flight model. There are no mechanical parts that need to be lubricated or require special maintenance. However, after each flight operation, you should clean the quadcopter of possible contamination (wool threads, hair, dust etc.).

For cleaning, use a dry or slightly damp cloth and avoid contact between water and the electronics, rechargeable battery and motors.

## b) Replacing the Rotors

If a rotor is damaged in a crash or other action, replace it immediately. This also applies if there are any fine tears or grazing in the rotor. Due to the high speed, material parts could come loose if the rotors are damaged and this could lead to damage to or endangerment of the environment.

To replace a rotor, carefully lever the damaged rotor from the motor shaft with a suitable tool (e.g. flat-head screwdriver) and replace it by a new one. Installation must be performed with the necessary caution and the corresponding care.

For orientation, put the quadcopter onto your work surface so that the black rotors of the model point forward.

The front rotors (figure 18, items 1 and 2) must have black rotors. Rotor 1 turns clockwise, rotor 2 turns counter clockwise.

The rear rotors (figure 18, items 3 and 4) must have white rotors. Rotor 3 turns counter clockwise, rotor 4 turns clockwise.

Do not bend the drive shafts. Bent shafts (e.g. from crashes) influence the flight properties negatively due to the vibration that results and the irritation to the sensors. Motors with bent shaft must be replaced.

The rotating direction is marked at the bottom of the rotors ("A" or "B").

The rotors marked "A" must be installed on the rotors that turn to the left (counter clockwise).

The rotors marked "B" must be installed on the rotors that turn to the right (clockwise).

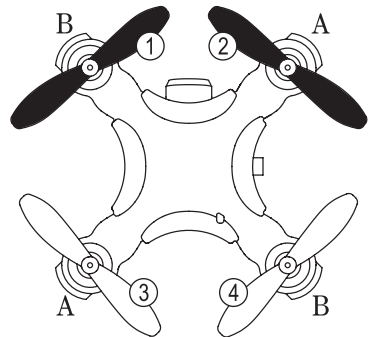

Figure 18



### Attention!

Please observe the rotating direction of the respective motor and the choice of the corresponding rotor without fail. If these are incorrectly chosen, the model will not be able to fly and will act in an erratic way when next started! Loss of guarantee/warranty!

### c) Calibration with the Transmitter

The quadcopter "Q Pro FPV" is delivered calibrated perfectly ex works. After harder landings or crashes, it is possible that the quadcopter will no longer fly as usual. In this case, you should recalibrate the quadcopter.

→ Calibration can be performed in operation with the Smartphone (see chapter 13) or the remote control transmitter (see this chapter).

Put the quadcopter onto a level surface ready to start. Put both control levers in the position right/bottom (see figure 19). Hold both control levers in this position.

The LEDs start to flash. Once these LEDs are permanently lit, calibration is successfully completed. Now, put both control levers into the neutral position again. You can now resume flying.



Figure 19

## 15. Disposal

---

### a) Product



Electronic devices are recyclable and should not be disposed of in household waste. Dispose of the product according to the applicable statutory provisions at the end of its service life.



Remove any inserted batteries/rechargeable batteries and dispose of them separately from the product.

### b) Batteries/Rechargeable Batteries

You as the end user are required by law (Battery Ordinance) to return all used batteries/rechargeable batteries. Disposing of them in the household waste is prohibited.



Batteries/rechargeable batteries that contain hazardous substances are labelled with the adjacent icon to indicate that disposal in domestic waste is forbidden. The descriptions for the respective heavy metals are: Cd = cadmium, Hg = mercury, Pb = lead (the names are indicated on the battery/rechargeable battery e.g. below the rubbish bin symbol shown on the left).

You may return used batteries/rechargeable batteries free of charge at the official collection points in your community, in our stores, or wherever batteries/rechargeable batteries are sold.

You thus fulfil your statutory obligations and contribute to the protection of the environment.

## 16. Declaration of Conformity (DOC)

---

Conrad Electronic SE, Klaus-Conrad-Straße 1, D-92240 Hirschau, hereby declares that this product complies with directive 2014/53/EU.



The complete text of the EU declaration of conformity is available under the following web address:

[www.conrad.com/downloads](http://www.conrad.com/downloads)

Choose a language by clicking a flag symbol and enter the item number of the product into the search field; then you may download the EU declaration of conformity in the PDF format.

# 17. Technical Data

---

## a) Transmitter

Transmission frequency.....	2.4 GHz
Transmission output .....	5 mW
Transmitter range .....	max. 20 - 25 m (free field)
Operating voltage .....	3 V/DC (2 type micro/AAA batteries)
Dimensions (W x L x H).....	155 x 104 x 54 mm
Weight (without batteries).....	approx. 155 g

## b) Quadrocopter

Transmission frequency for FPV video image..	2.4 GHz (WiFi)
Transmission output for FPV video image.....	10 mW
Total height .....	28 mm
Diameter .....	44 mm
Diameter of the rotors.....	30 mm
Take-off weight .....	approx. 19 g
Camera resolution .....	0.4 Mp
Resolution (photo and video).....	720 x 576
Frame rate .....	25 frames/s
Video format .....	AVI
Image format .....	JPG
Permissible flight operation .....	in buildings and in wind still conditions
Permitted temperature range.....	0 °C to +40 °C
Permitted humidity.....	max. 75% rel. humidity, non-condensing

## c) USB Charger

Operating voltage .....	5 V/DC (via USB)
Required input current.....	min. 500 mA
Charge end voltage .....	4.2 V (LiPo 1S)
Charge time .....	approx. 30 minutes

**GB** This is a publication by Conrad Electronic SE, Klaus-Conrad-Str. 1, D-92240 Hirschau ([www.conrad.com](http://www.conrad.com)).

All rights including translation reserved. Reproduction by any method, e.g. photocopy, microfilming, or the capture in electronic data processing systems require the prior written approval by the editor. Reprinting, also in part, is prohibited. This publication represent the technical status at the time of printing.

Copyright 2017 by Conrad Electronic SE.