

Robert Bosch Power Tools GmbH
70538 Stuttgart
GERMANY

www.bosch-pt.com

1 609 92A 2SJ (2016.08) O / 230



1 609 92A 2SJ

GSR | GSB Professional

18V-60 C



de Originalbetriebsanleitung
en Original instructions
fr Notice originale
es Manual original
pt Manual original
it Istruzioni originali
nl Oorspronkelijke gebruiksaanwijzing
da Original brugsanvisning
sv Bruksanvisning i original
no Original driftsinstruks
fi Alkuperäiset ohjeet
el Πρωτότυπο οδηγιών χρήσης
tr Orijinal işletme talimatı

pl Instrukcja oryginalna
cs Původní návod k používání
sk Pôvodný návod na použitie
hu Eredeti használati utasítás
ru Оригинальное руководство по эксплуатации
uk Оригінальна інструкція з експлуатації
kk Пайдалану нұсқаулығының түпнұсқасы
ro Instrucțiuni originale
bg Оригинална инструкция
mk Оригинално упатство за работа
sr Originalno uputstvo za rad

sl Izvirna navodila
hr Originalne upute za rad
et Algupärane kasutusjuhend
lv Instrukcijas oriģinālvalodā
lt Originali instrukcija
ko 사용 설명서 원본
ar تعليمات التشغيل الأصلية
fa دفترچه راهنمای اصلی



Deutsch.....	Seite	6
English.....	Page	13
Français.....	Page	20
Español.....	Página	27
Português.....	Página	34
Italiano.....	Página	41
Nederlands.....	Página	48
Dansk.....	Side	55
Svenska.....	Sida	61
Norsk.....	Side	67
Suomi.....	Sivu	73
Ελληνικά.....	Σελίδα	80
Türkçe.....	Sayfa	87
Polski.....	Strona	93
Česky.....	Strana	101
Slovensky.....	Strana	107
Magyar.....	Oldal	114
Русский.....	Страница	121
Українська.....	Сторінка	129
Қазақша.....	Бет	137
Română.....	Pagina	144
Български.....	Страница	151
Македонски.....	Страна	158
Srpski.....	Strana	165
Slovensko.....	Stran	172
Hrvatski.....	Stranica	178
Eesti.....	Lehekülg	184
Latviešu.....	Lappuse	191
Lietuviškai.....	Puslapis	198
한국어.....	페이지	204
عربي.....	صفحة	217
فارسی.....	صفحه	224

CE |

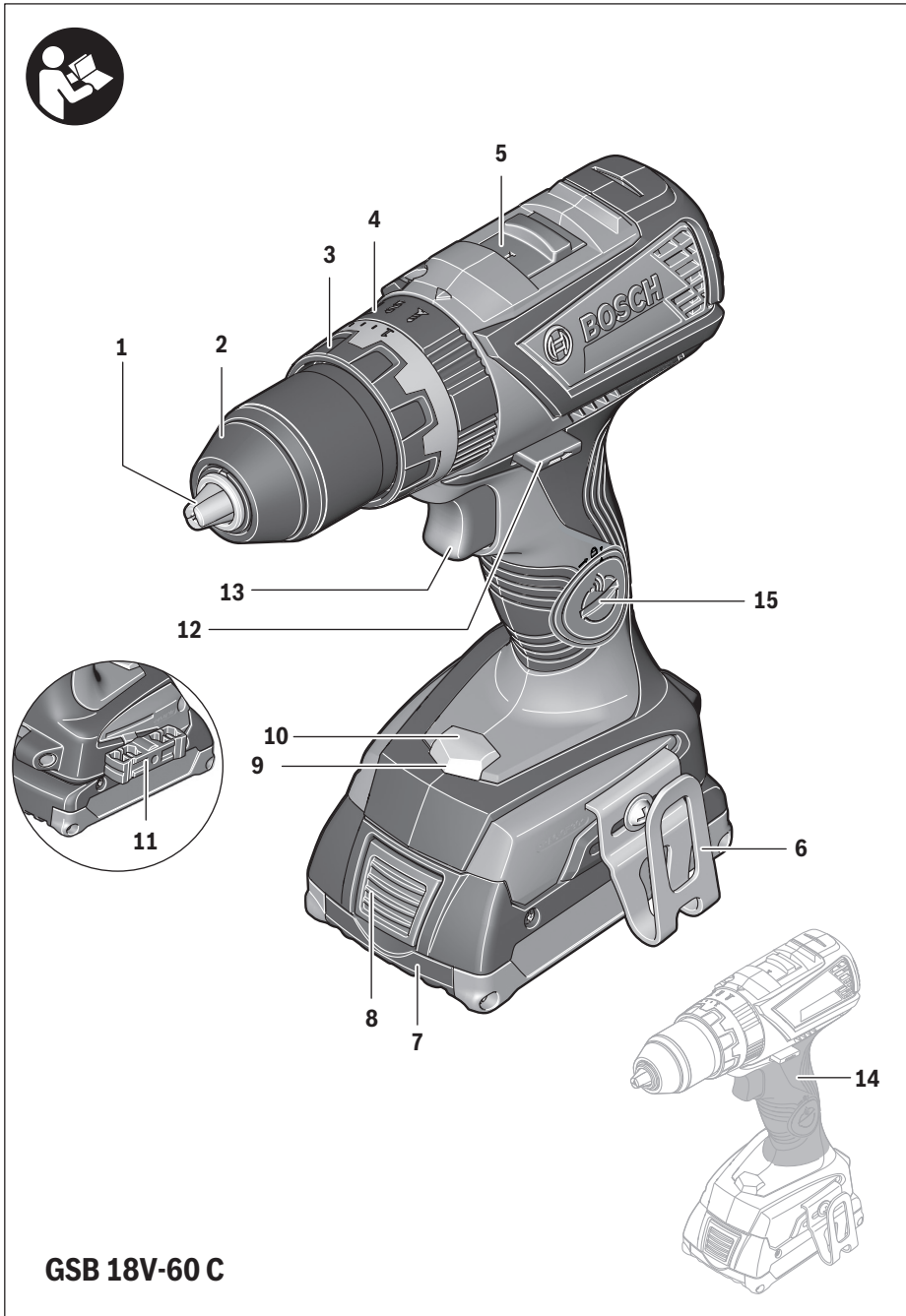

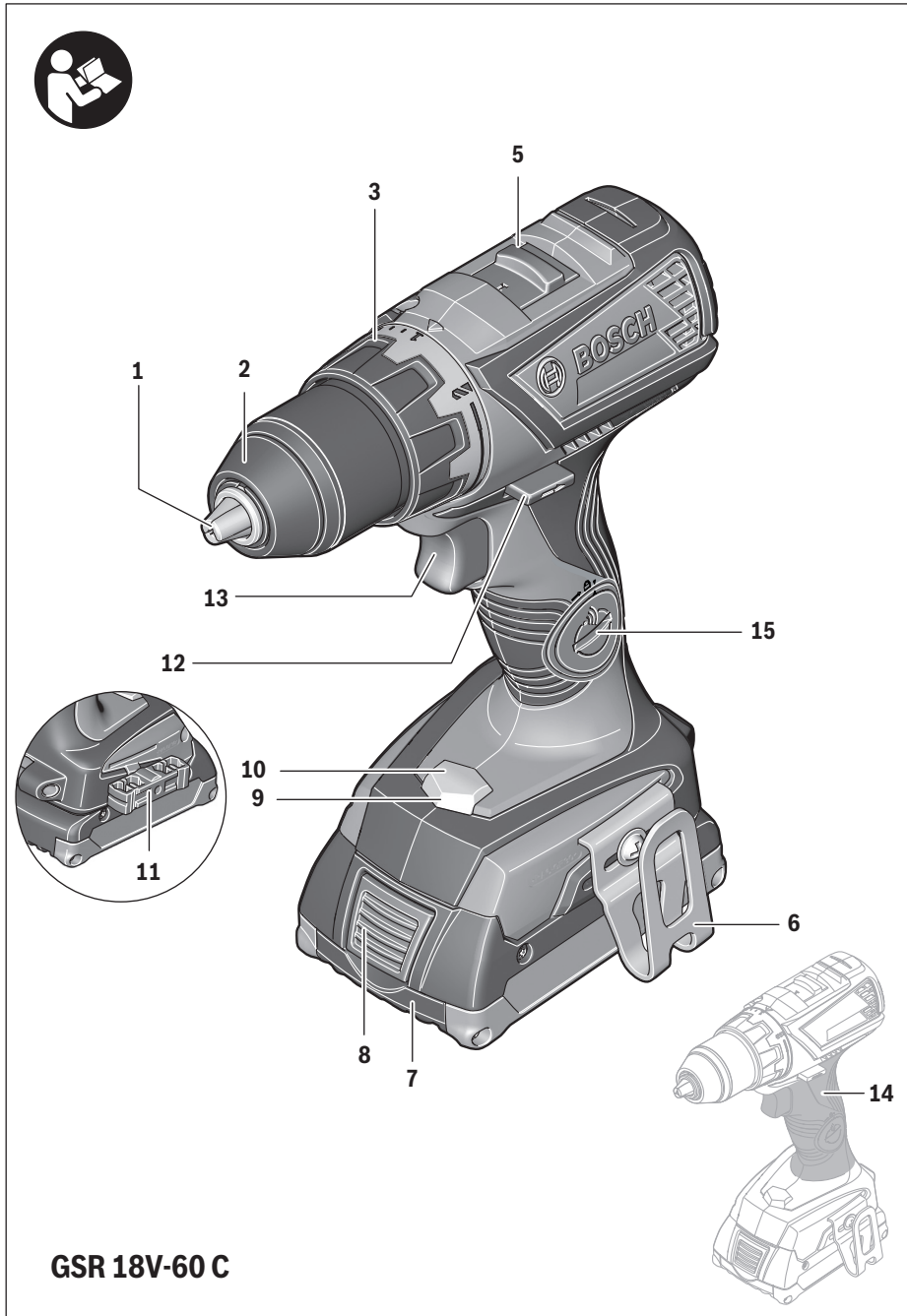

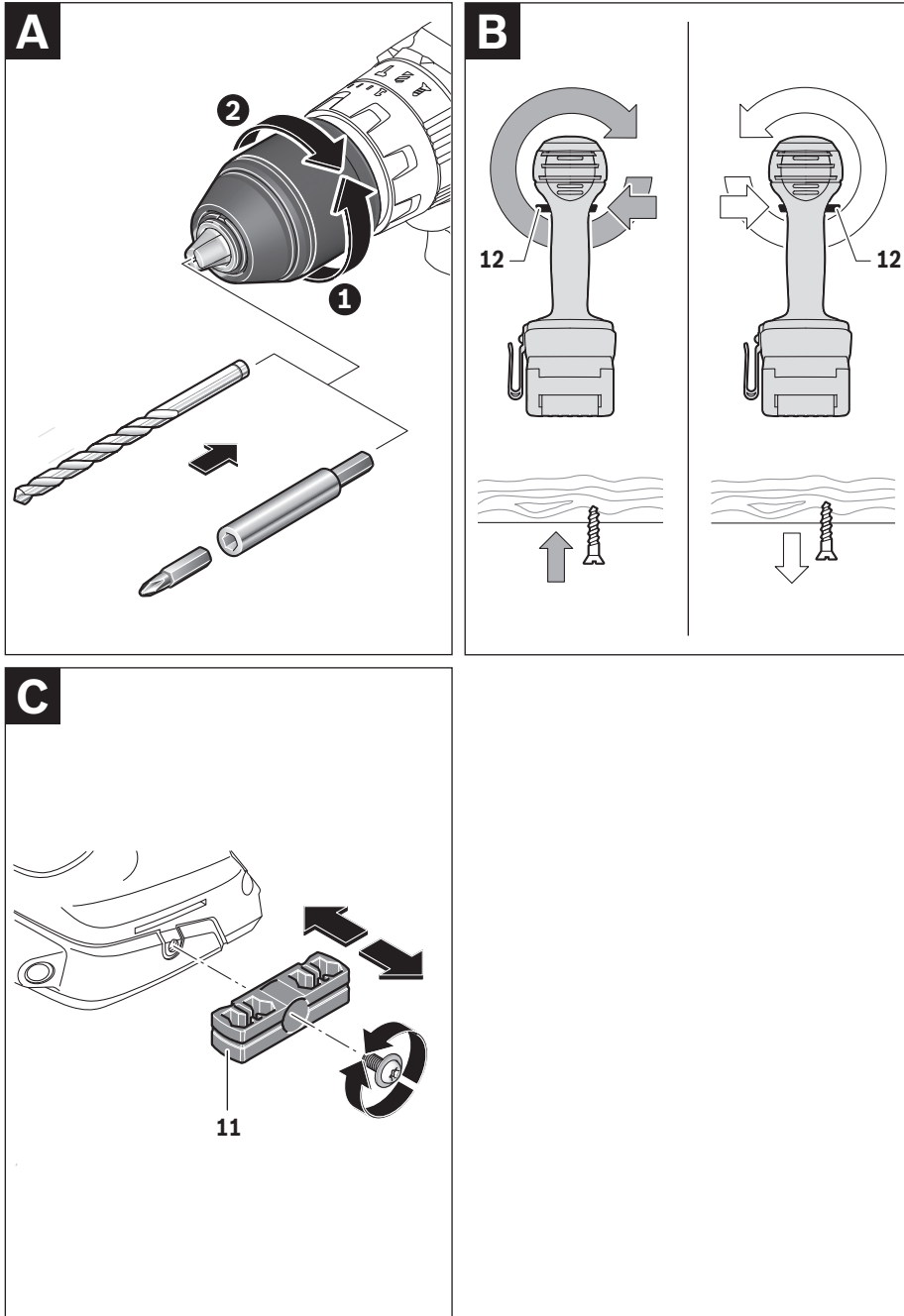

Nur für EU-Länder:

Gemäß der europäischen Richtlinie 2012/19/EU müssen nicht mehr gebrauchsfähige Elektrowerkzeuge und gemäß der europäischen Richtlinie 2006/66/EG müssen defekte oder verbrauchte Akkus/Batterien getrennt gesammelt und einer umweltgerechten Wiederverwendung zugeführt werden.

Nicht mehr gebrauchsfähige Akkus/Batterien können direkt abgegeben werden bei:

Deutschland

Recyclingzentrum Elektrowerkzeuge
Osteroder Landstraße 3
37589 Kalefeld

Schweiz

Batrec AG
3752 Wimmis BE

Akkus/Batterien:**Li-Ion:**

Bitte beachten Sie die Hinweise im Abschnitt „Transport“, Seite 12.

Änderungen vorbehalten.

English

Safety Notes

General Power Tool Safety Warnings

⚠ WARNING Read all safety warnings and all instructions. Failure to follow the warnings and instructions may result in electric shock, fire and/or serious injury.

Save all warnings and instructions for future reference.

The term “power tool” in the warnings refers to your mains-operated (corded) power tool or battery-operated (cordless) power tool.

Work area safety

- ▶ **Keep work area clean and well lit.** Cluttered or dark areas invite accidents.
- ▶ **Do not operate power tools in explosive atmospheres, such as in the presence of flammable liquids, gases or dust.** Power tools create sparks which may ignite the dust or fumes.
- ▶ **Keep children and bystanders away while operating a power tool.** Distractions can cause you to lose control.

Electrical safety

- ▶ **Power tool plugs must match the outlet. Never modify the plug in any way. Do not use any adapter plugs with earthed (grounded) power tools.** Unmodified plugs and matching outlets will reduce risk of electric shock.
- ▶ **Avoid body contact with earthed or grounded surfaces, such as pipes, radiators, ranges and refrigerators.** There is an increased risk of electric shock if your body is earthed or grounded.
- ▶ **Do not expose power tools to rain or wet conditions.** Water entering a power tool will increase the risk of electric shock.
- ▶ **Do not abuse the cord. Never use the cord for carrying, pulling or unplugging the power tool. Keep cord away from heat, oil, sharp edges and moving parts.** Damaged or entangled cords increase the risk of electric shock.
- ▶ **When operating a power tool outdoors, use an extension cord suitable for outdoor use.** Use of a cord suitable for outdoor use reduces the risk of electric shock.
- ▶ **If operating a power tool in a damp location is unavoidable, use a residual current device (RCD) protected supply.** Use of an RCD reduces the risk of electric shock.

Personal safety

- ▶ **Stay alert, watch what you are doing and use common sense when operating a power tool. Do not use a power tool while you are tired or under the influence of drugs, alcohol or medication.** A moment of inattention while operating power tools may result in serious personal injury.
- ▶ **Use personal protective equipment. Always wear eye protection.** Protective equipment such as dust mask, non-skid safety shoes, hard hat, or hearing protection used for appropriate conditions will reduce personal injuries.
- ▶ **Prevent unintentional starting. Ensure the switch is in the off-position before connecting to power source and/or battery pack, picking up or carrying the tool.** Carrying power tools with your finger on the switch or energising power tools that have the switch on invites accidents.
- ▶ **Remove any adjusting key or wrench before turning the power tool on.** A wrench or a key left attached to a rotating part of the power tool may result in personal injury.
- ▶ **Do not overreach. Keep proper footing and balance at all times.** This enables better control of the power tool in unexpected situations.
- ▶ **Dress properly. Do not wear loose clothing or jewellery. Keep your hair, clothing and gloves away from moving parts.** Loose clothes, jewellery or long hair can be caught in moving parts.
- ▶ **If devices are provided for the connection of dust extraction and collection facilities, ensure these are connected and properly used.** Use of dust collection can reduce dust-related hazards.

14 | English

Power tool use and care

- ▶ **Do not force the power tool. Use the correct power tool for your application.** The correct power tool will do the job better and safer at the rate for which it was designed.
- ▶ **Do not use the power tool if the switch does not turn it on and off.** Any power tool that cannot be controlled with the switch is dangerous and must be repaired.
- ▶ **Disconnect the plug from the power source and/or the battery pack from the power tool before making any adjustments, changing accessories, or storing power tools.** Such preventive safety measures reduce the risk of starting the power tool accidentally.
- ▶ **Store idle power tools out of the reach of children and do not allow persons unfamiliar with the power tool or these instructions to operate the power tool.** Power tools are dangerous in the hands of untrained users.
- ▶ **Maintain power tools. Check for misalignment or binding of moving parts, breakage of parts and any other condition that may affect the power tool's operation. If damaged, have the power tool repaired before use.** Many accidents are caused by poorly maintained power tools.
- ▶ **Keep cutting tools sharp and clean.** Properly maintained cutting tools with sharp cutting edges are less likely to bind and are easier to control.
- ▶ **Use the power tool, accessories and tool bits etc. in accordance with these instructions, taking into account the working conditions and the work to be performed.** Use of the power tool for operations different from those intended could result in a hazardous situation.

Battery tool use and care

- ▶ **Recharge only with the charger specified by the manufacturer.** A charger that is suitable for one type of battery pack may create a risk of fire when used with another battery pack.
- ▶ **Use power tools only with specifically designated battery packs.** Use of any other battery packs may create a risk of injury and fire.
- ▶ **When battery pack is not in use, keep it away from other metal objects, like paper clips, coins, keys, nails, screws or other small metal objects, that can make a connection from one terminal to another.** Shorting the battery terminals together may cause burns or a fire.
- ▶ **Under abusive conditions, liquid may be ejected from the battery; avoid contact. If contact accidentally occurs, flush with water. If liquid contacts eyes, additionally seek medical help.** Liquid ejected from the battery may cause irritation or burns.



Service

- ▶ **Have your power tool serviced by a qualified repair person using only identical replacement parts.** This will ensure that the safety of the power tool is maintained.

Safety Warnings for Drills and Screwdrivers**GSB 18V-60 C**

- ▶ **Wear ear protectors when impact drilling.** Exposure to noise can cause hearing loss.

GSR 18V-60 C / GSB 18V-60 C

- ▶ **Hold power tool by insulated gripping surfaces when performing an operation where the cutting accessory or fastener may contact hidden wiring.** Cutting accessory and fasteners contacting a "live" wire may make exposed metal parts of the power tool "live" and could give the operator an electric shock.
 - ▶ **Use auxiliary handle(s), if supplied with the tool.** Loss of control can cause personal injury.
 - ▶ **Use appropriate detectors to determine if utility lines are hidden in the work area or call the local utility company for assistance.** Contact with electric lines can lead to fire and electric shock. Damaging a gas line can lead to explosion. Penetrating a water line causes property damage.
 - ▶ **Switch off the power tool immediately when the tool insert jams. Be prepared for high reaction torque that can cause kickback.** The tool insert jams when:
 - the power tool is subject to overload or
 - it becomes wedged in the workpiece.
 - ▶ **Hold the machine with a firm grip.** High reaction torque can briefly occur while driving in and loosening screws.
 - ▶ **Secure the workpiece.** A workpiece clamped with clamping devices or in a vice is held more secure than by hand.
 - ▶ **Always wait until the machine has come to a complete stop before placing it down.** The tool insert can jam and lead to loss of control over the power tool.
 - ▶ **Do not open the battery.** Danger of short-circuiting.
-  **Protect the battery against heat, e. g., against continuous intense sunlight, fire, water, and moisture.** Danger of explosion.
- 
- ▶ **In case of damage and improper use of the battery, vapours may be emitted. Ventilate the area and seek medical help in case of complaints.** The vapours can irritate the respiratory system.
 - ▶ **Use the battery only in conjunction with your Bosch power tool.** This measure alone protects the battery against dangerous overload.
 - ▶ **The battery can be damaged by pointed objects such as nails or screwdrivers or by force applied externally.** An internal short circuit can occur and the battery can burn, smoke, explode or overheat.
 - ▶ **The battery is supplied partially charged. To ensure full battery capacity, completely charge the battery in the battery charger before using for the first time.**
 - ▶ **Read the operating instructions of the battery charger.**
 - ▶ **Read the operating instructions of the Bluetooth® Low Energy Module GCY 30-4.**

- ▶ **Adjust the gear switch only when the machine is at a complete stop.**
- ▶ **Always push the gear selector and turn the operating mode selector switch through to the stop.** Otherwise, the machine can become damaged.
- ▶ **Before any work on the machine (e. g., maintenance, tool change, etc.) as well as during transport and storage, set the rotational direction switch to the centre position.** Unintentional actuation of the On/Off switch can lead to injuries.
- ▶ **Caution! When using the power tool with Bluetooth®, interference can occur with other devices and equipment, aircraft and medical devices (e. g. pacemakers, hearing aids). Also, damage to people and animals in the immediate vicinity cannot be completely excluded. Do not use the power tool with Bluetooth® near medical devices, petrol stations, chemical plants, in areas where there is a danger of explosion and where blasting takes place. Do not use the power tool with Bluetooth® in aircraft. Avoid using the product near your body for extended periods.**

The **Bluetooth®** word mark and logos are registered trademarks owned by Bluetooth SIG, Inc. and any use of such marks by Robert Bosch Power Tools GmbH is under licence.

Product Description and Specifications



Read all safety warnings and all instructions. Failure to follow the warnings and instructions may result in electric shock, fire and/or serious injury.

While reading the operating instructions, unfold the graphics page for the machine and leave it open.

Intended Use

The machine is intended for driving in and loosening screws as well as for drilling in wood, metal, ceramics and plastic. GSB machines are additionally intended for impact drilling in bricks, brickwork and masonry.

The light of this power tool is intended to illuminate the power tool's direct area of working operation and is not suitable for household room illumination.

With the **Bluetooth®** Low Energy Module GCY 30-4 inserted, data and settings of the power tool can be transferred between the power tool and a mobile terminal device by means of **Bluetooth®** wireless technology.

Product Features

The numbering of the product features refers to the illustration of the machine on the graphics page.

- 1 Tool holder
- 2 Keyless chuck
- 3 Torque presetting ring
- 4 Mode selector switch (GSB 18V-60 C)
- 5 Gear selector
- 6 Belt clip
- 7 Battery pack
- 8 Battery unlocking button
- 9 Worklight
- 10 Overload protector indicator
- 11 Universal bit holder*
- 12 Rotational direction switch
- 13 On/Off switch
- 14 Handle (insulated gripping surface)
- 15 Cover for **Bluetooth®** Low Energy Module GCY 30-4

*Accessories shown or described are not part of the standard delivery scope of the product. A complete overview of accessories can be found in our accessories program.

Technical Data

Cordless Screwdriver		GSR 18V-60 C	GSB 18V-60 C
Article number		3 601 JG1 1..	3 601 JG2 1..
Rated voltage	V=	18	18
No-load speed			
– 1st gear	min ⁻¹	0 – 600	0 – 600
– 2nd gear	min ⁻¹	0 – 1900	0 – 1900
Impact rate	min ⁻¹	–	0-28 500
Max. torque for soft screwdriving application according to ISO 5393	Nm	31*	31*
Maximum torque, hard screwdriving application according to ISO 5393	Nm	60*	60*

*depending on the battery pack being used

** limited performance at temperatures <0 °C

A) The mobile terminal devices must be compatible with **Bluetooth®** Low Energy devices (version 4.1) and support the Generic Access Profile (GAP).

B) The signal range may vary greatly depending on external conditions, including the receiving device used. The **Bluetooth®** range may be significantly weaker inside closed rooms and through metallic barriers (e. g. walls, shelving units, cases, etc.).

16 | English

Cordless Screwdriver		GSR 18V-60 C	GSB 18V-60 C
Maximum drilling diameter (1st/2nd gear)			
- Wood	mm	38	38
- Steel	mm	13	13
- Brickwork	mm	-	13
Tool holder		1.5 – 13	1.5 – 13
Max. screw dia.	mm	10	10
Weight according to EPTA-Procedure 01:2014	kg	1.5/1.7*	1.5/ 1.8*
Permitted ambient temperature			
- during charging **	°C	0... +45	0... +45
- during operation ** and during storage	°C	-20... +50	-20... +50
Recommended batteries		GBA 18V.. GBA 18V... W	GBA 18V.. GBA 18V... W
Recommended chargers		AL 18.. GAL 3680	AL 18.. GAL 3680
Recommended chargers for wireless charging batteries		GAL 18... W	GAL 18... W
Data transmission			
Bluetooth®		Bluetooth® 4.1 (Low Energy) ^{A)}	Bluetooth® 4.1 (Low Energy) ^{A)}
Signal interval		8 s	8 s
Signal range		maximum 30 m ^{B)}	maximum 30 m ^{B)}

*depending on the battery pack being used

** limited performance at temperatures < 0 °C

A) The mobile terminal devices must be compatible with Bluetooth® Low Energy devices (version 4.1) and support the Generic Access Profile (GAP).

B) The signal range may vary greatly depending on external conditions, including the receiving device used. The Bluetooth® range may be significantly weaker inside closed rooms and through metallic barriers (e. g. walls, shelving units, cases, etc.).

Noise/Vibration Information

Sound emission values determined according to EN 60745-2-1, EN 60745-2-2.

Typically the A-weighted noise levels of the product are: Sound pressure level 87 dB(A); Sound power level 98 dB(A).

Uncertainty K = 3 dB.

Wear hearing protection!

		GSR 18V-60 C	GSB 18V-60 C
Vibration total values a_h (triax vector sum) and uncertainty K determined according to EN 60745-2-2.			
Drilling in metal:			
a_h	m/s^2	<2.5	<2.5
K	m/s^2	1.5	1.5
Impact drilling in concrete:			
a_h	m/s^2	-	8.0
K	m/s^2	-	1.5
Screwdriving:			
a_h	m/s^2	<2.5	<2.5
K	m/s^2	1.5	1.5

The vibration level given in this information sheet has been measured in accordance with a standardised test given in EN 60745 and may be used to compare one tool with another. It may be used for a preliminary assessment of exposure. The declared vibration emission level represents the main applications of the tool. However if the tool is used for different applications, with different accessories or insertion tools or is poorly maintained, the vibration emission may differ. This

may significantly increase the exposure level over the total working period.

An estimation of the level of exposure to vibration should also take into account the times when the tool is switched off or when it is running but not actually doing the job. This may significantly reduce the exposure level over the total working period.

Identify additional safety measures to protect the operator from the effects of vibration such as: maintain the tool and the accessories, keep the hands warm, organisation of work patterns.

Assembly

Inserting the *Bluetooth*® Low Energy Module GCY 30-4 (accessory)

Read the corresponding operating instructions for information about the *Bluetooth*® Low Energy Module GCY 30-4.

Battery Charging

Note: The battery supplied is partially charged. To ensure full capacity of the battery, completely charge the battery in the battery charger before using your power tool for the first time.

The lithium-ion battery can be charged at any time without reducing its service life. Interrupting the charging procedure does not damage the battery.

The lithium-ion battery is protected against deep discharging by the "Electronic Cell Protection (ECP)". When the battery is empty, the machine is switched off by means of a protective circuit: The inserted tool no longer rotates.

- ▶ **Do not continue to press the On/Off switch after the machine has been automatically switched off.** The battery can be damaged.

Removing the battery

The battery **7** is equipped with two locking levels that should prevent the battery from falling out when pushing the battery unlocking button **8** unintentionally. As long as the battery is inserted in the power tool, it is held in position by means of a spring.

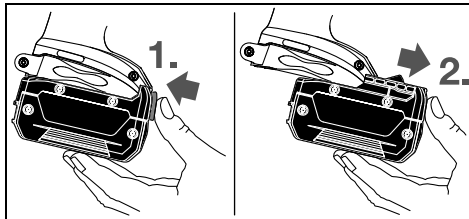

To remove the battery **7**, press the unlocking button **8** and pull out the battery toward the front. **Do not exert any force.**

Changing the Tool (see figure A)

- ▶ **Before any work on the machine itself (e. g. maintenance, tool change, etc.) as well as during transport and storage, remove the battery from the power tool.**

There is danger of injury when unintentionally actuating the On/Off switch.

Open the keyless chuck **2** by turning in rotation direction **1**, until the tool can be inserted. Insert the tool.

Firmly tighten the collar of the keyless chuck **2** by hand in rotation direction **2**. This automatically locks the drill chuck.

Dust/Chip Extraction

- ▶ **Dust from materials such as lead-containing coatings, some wood types, minerals and metal can be harmful to one's health and cause allergic reactions, lead to respiratory infections and/or cancer.** Materials containing asbestos may only be worked by specialists.

- Provide for good ventilation of the working place.
- It is recommended to wear a P2 filter-class respirator.

Observe the relevant regulations in your country for the materials to be worked.

- ▶ **Prevent dust accumulation at the workplace.** Dust can easily ignite.

Operation

Starting Operation

Inserting the battery

Note: Use of batteries not suitable for the machine can lead to malfunctions of or cause damage to the power tool.

Set the rotational direction switch **12** to the centre position in order to avoid unintentional starting. Insert the charged battery **7** into the handle so that it can be felt to engage and faces flush against the handle.

Reversing the rotational direction (see figure B)

The rotational direction switch **12** is used to reverse the rotational direction of the machine. However, this is not possible with the On/Off switch **13** actuated.

- 🔄 **Rotate clockwise:** Move the rotational direction switch **12** on both sides up to the stop into position **◀**.
- 🔄 **Rotate anticlockwise:** Move the rotational direction switch **12** on both sides up to the stop into position **▶**.

Setting the operating mode



Drilling

GSR 18V-60 C:

Set the torque selector setting ring **3** to the required torque.

GSB 18V-60 C:

Set the operating mode selector switch **4** to the "drilling" symbol.



Screwdriving

GSR 18V-60 C:

Set the torque selector setting ring **3** to the "screwdriving" symbol.

GSB 18V-60 C:

Set the operating mode selector switch **4** to the "screwdriving" symbol.



Impact drilling (GSB 18V-60 C)

Set the operating mode selector switch **4** to the "impact drilling" symbol.

18 | English

Switching On and Off

To **start** the machine, press the On/Off switch **13** and keep it pressed.

The LED **10** lights up when the On/Off switch **13** is halfway or fully pressed, and enables illumination of the screwing location in unfavourable light conditions.

To save energy, only switch the power tool on when using it.

Adjusting the Speed

The speed of the switched-on power tool can be variably adjusted, depending on how far the On/Off switch **13** is pressed.

Light pressure on the On/Off switch **13** results in a low rotational speed. Further pressure on the switch results in an increase in speed.

Setting the torque

With the torque preselection ring **3**, the required torque can be preselected in 20 steps. The inserted tool is stopped as soon as the set torque is reached.

Gear selection, mechanical

► **The gear selector 5 can be actuated at standstill or when the machine is running. However, this should not be done while operating at full load or maximum speed.**

1st gear:

Low speed range; for working with large drilling diameters.

2nd gear:

High speed range; for drilling with small drilling diameter.

Temperature Dependent Overload Protection

In normal conditions of use, the power tool cannot be overloaded. If the power tool is overloaded or not kept within the permitted operating temperature range, the speed is reduced. The power tool will not run at full speed again until the permitted operating temperature has been reached.

Activation of the temperature-controlled overload protector is indicated by the LED **10** on the power tool lighting up red. To reach the permitted operating temperature range again, either switch the gear selector **5** to gear 1, run the power tool at no load or wait until the LED **10** extinguishes. When the LED **10** has extinguished, the tool has reached the permitted operating temperature range again.

Protection Against Deep Discharging

The lithium-ion battery is protected against deep discharging by the "Electronic Cell Protection (ECP)". When the battery is empty, the machine is switched off by means of a protective circuit: The inserted tool no longer rotates.

Rapid Shut-off

The rapid shut-off feature enables better control of the power tool. The power tool shuts off in case of sudden and unexpected rotation of the power tool around the drilling axis.

The rapid shut-off feature is indicated by a flashing LED on the power tool.

To **restart the machine**, release the On/Off switch and then actuate again.

► **Rapid shut-off can trigger only when the power tool is running at maximum operating speed and can rotate freely around the drill bit axis.** Choose a suitable work position for this. Otherwise, rapid shut-off will not be ensured.

Connectivity functions

In conjunction with the *Bluetooth*® Low Energy Module GCY 30-4 (accessory), the following connectivity functions are available for the power tool:

- Registration and personalisation
- Status check, output of warning messages
- General information and settings
- Management

Read the corresponding operating instructions for information about the *Bluetooth*® Low Energy Module GCY 30-4.

Working Advice

► **The power tool with inserted *Bluetooth*® Low Energy Module GCY 30-4 (accessory) is equipped with a radio interface. Local operating restrictions, e.g. in aircraft or hospitals, must be observed.**

► **Apply the power tool to the screw only when it is switched off.** Rotating tool inserts can slip off.

An auxiliary tool can be used to remove the screwdriver bit or universal bit holder.

Belt Clip

With the belt clip **6**, the machine can be hung onto a belt. The user has both hands free and the machine is always at hand.

Maintenance and Service**Maintenance and Cleaning**

► **Before any work on the machine itself (e. g. maintenance, tool change, etc.) as well as during transport and storage, remove the battery from the power tool.**

There is danger of injury when unintentionally actuating the On/Off switch.

► **For safe and proper working, always keep the machine and ventilation slots clean.**

When the battery is no longer operative, please refer to an authorised after-sales service agent for Bosch power tools.

After-sales Service and Application Service

Our after-sales service responds to your questions concerning maintenance and repair of your product as well as spare parts. Exploded views and information on spare parts can also be found under:

www.bosch-pt.com

Bosch's application service team will gladly answer questions concerning our products and their accessories.

In all correspondence and spare parts orders, please always include the 10-digit article number given on the nameplate of the product.

Great Britain

Robert Bosch Ltd. (B.S.C.)
P.O. Box 98
Broadwater Park
North Orbital Road
Denham
Uxbridge
UB 9 5HJ

At www.bosch-pt.co.uk you can order spare parts or arrange the collection of a product in need of servicing or repair.

Tel. Service: (0344) 7360109

E-Mail: boschservicecentre@bosch.com

Ireland

Origo Ltd.
Unit 23 Magna Drive
Magna Business Park
City West
Dublin 24

Tel. Service: (01) 4666700

Fax: (01) 4666888

Australia, New Zealand and Pacific Islands

Robert Bosch Australia Pty. Ltd.

Power Tools

Locked Bag 66

Clayton South VIC 3169

Customer Contact Center

Inside Australia:

Phone: (01300) 307044

Fax: (01300) 307045

Inside New Zealand:

Phone: (0800) 543353

Fax: (0800) 428570

Outside AU and NZ:

Phone: +61 3 95415555

www.bosch.com.au

Supplier code ERAC000385

Republic of South Africa**Customer service**

Hotline: (011) 6519600

Gauteng – BSC Service Centre

35 Roper Street, New Centre

Johannesburg

Tel.: (011) 4939375

Fax: (011) 4930126

E-Mail: bsctools@icon.co.za

KZN – BSC Service Centre

Unit E, Almar Centre

143 Crompton Street

Pinetown

Tel.: (031) 7012120

Fax: (031) 7012446

E-Mail: bsc.dur@za.bosch.com

Western Cape – BSC Service Centre

Democracy Way, Prosperity Park

Milnerton

Tel.: (021) 5512577

Fax: (021) 5513223

E-Mail: bsc@zsd.co.za

Bosch Headquarters

Midrand, Gauteng

Tel.: (011) 6519600

Fax: (011) 6519880

E-Mail: rbsa-hq.pts@za.bosch.com

Transport

The contained lithium-ion batteries are subject to the Dangerous Goods Legislation requirements. The user can transport the batteries by road without further requirements.

When being transported by third parties (e. g.: air transport or forwarding agency), special requirements on packaging and labelling must be observed. For preparation of the item being shipped, consulting an expert for hazardous material is required.

Dispatch batteries only when the housing is undamaged.

Tape or mask off open contacts and pack up the battery in such a manner that it cannot move around in the packaging. Please also observe possibly more detailed national regulations.

Disposal

The machine, rechargeable batteries, accessories and packaging should be sorted for environmental-friendly recycling.

Do not dispose of power tools and batteries/rechargeable batteries into household waste!

Only for EC countries:

According to the European Guideline 2012/19/EU, power tools that are no longer usable, and according to the European Guideline 2006/66/EC, defective or used battery packs/batteries, must be collected separately and disposed of in an environmentally correct manner.

Batteries no longer suitable for use can be directly returned at:

Great Britain

Robert Bosch Ltd. (B.S.C.)

P.O. Box 98

Broadwater Park

North Orbital Road

Denham

Uxbridge

UB 9 5HJ

At www.bosch-pt.co.uk you can order spare parts or arrange the collection of a product in need of servicing or repair.

Tel. Service: (0344) 7360109

E-Mail: boschservicecentre@bosch.com

Battery packs/batteries:**Li-ion:**

Please observe the instructions in section "Transport", page 19.

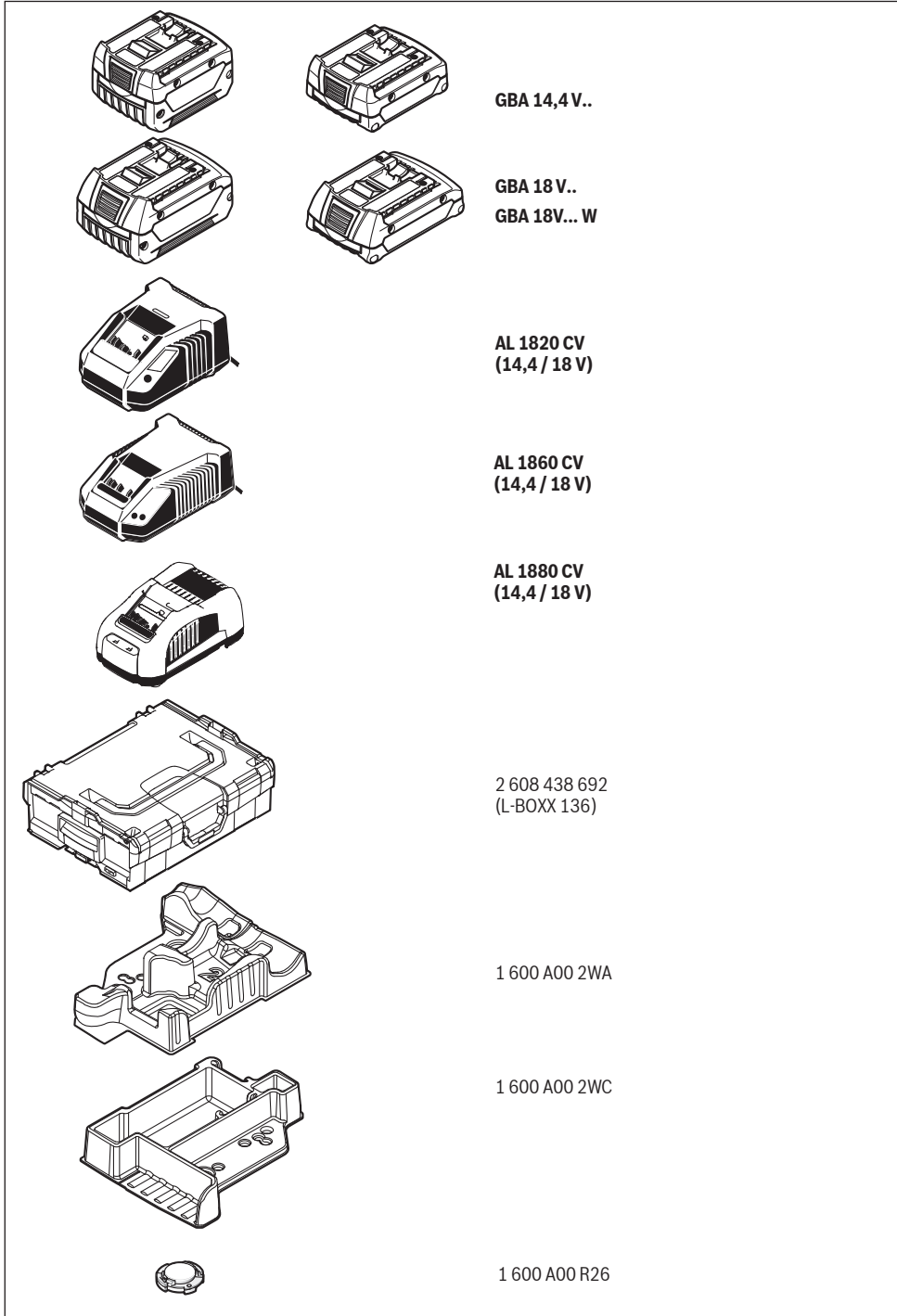

Subject to change without notice.



		CE
de	EU-Konformitätserklärung Akku-Bohrschrauber Sachnummer Akku-Schlagbohr- schrauber	Wir erklären in alleiniger Verantwortung, dass die genannten Produkte allen einschlägigen Bestimmungen der nachfolgend aufgeführten Richtlinien und Verordnungen entsprechen und mit folgenden Normen übereinstimmen. Technische Unterlagen bei: *
en	EU Declaration of Conformity Cordless Drill/Driver Article number Combination Cord- less Drill	We declare under our sole responsibility that the stated products comply with all applicable provisions of the directives and regulations listed below and are in conformity with the following standards. Technical file at: *
fr	Déclaration de conformité UE Perceuse-visseuse N° d'article sans fil Perceuse à percus- sion sans fil	Nous déclarons sous notre propre responsabilité que les produits décrits sont en conformité avec les directives, règlements normatifs et normes énumérés ci-dessous. Dossier technique auprès de: *
es	Declaración de conformidad UE Atornilladora taladra- N° de artículo dora accionada por acumulador Atornilladora-taladra- dora de percusión por acumulador	Declaramos bajo nuestra exclusiva responsabilidad, que los productos nombrados cumplen con todas las disposiciones correspondientes de las Directivas y los Reglamentos mencionados a continuación y están en conformidad con las siguientes normas. Documentos técnicos de: *
pt	Declaração de Conformidade CE Berbequim-apara- N.º do produto fusador sem fio Berbequim de percussão sem fio	Declaramos sob nossa exclusiva responsabilidade que os produtos mencio- nados cumprem todas as disposições e os regulamentos indicados e estão em conformidade com as seguintes normas. Documentação técnica pertencente à: *
it	Dichiarazione di conformità UE Cacciaviti/avvitatore Codice prodotto a batteria Trapano avvitatore a batteria con battente	Dichiariamo sotto la nostra piena responsabilità che i prodotti indicati sono conformi a tutte le disposizioni pertinenti delle Direttive e dei Regolamenti elencati di seguito, nonché alle seguenti Normative. Documentazione Tecnica presso: *
nl	EU-conformiteitsverklaring Accuboorschroeven- Productnummer draaiër Accuklopboor- schroevendraaiër	Wij verklaren op eigen verantwoordelijkheid dat de genoemde producten voldoen aan alle desbetreffende bepalingen van de hierna genoemde richt- lijnen en verordeningen en overeenstemmen met de volgende normen. Technisch dossier bij: *
da	EU-overensstemmelseserklæring Akku-boreskrue- Typenummer trækker Akku-slagboreskrue- trækker	Vi erklærer som eneansvarlige, at det beskrevne produkt er i overensstem- melse med alle gældende bestemmelser i følgende direktiver og forordninger og opfylder følgende standarder. Tekniske bilag ved: *
sv	EU-konformitetsförklaring Sladdlös borrar- Produktnummer dragare Sladdlös slagborrs- kruvdragare	Vi förklarar under eget ansvar att de nämnda produkterna uppfyller kraven i alla gällande bestämmelser i de nedan angivna direktiven och förordningar- nas och att de stämmer överens med följande normer. Teknisk dokumentation: *
no	EU-samsvarserklæring Batteri-boreskrue- Produktnummer trekker Batteri-slagbore- skruttrekker	Vi erklærer under eneansvar at de nevnte produktene er i overensstemmelse med alle relevante bestemmelser i direktivene og forordningene nedenfor og med følgende standarder. Teknisk dokumentasjon hos: *

CE		II
fi	EU-vaatimusten mukaisuusvakuutus Akkuuuvinväännin Tuotenumero Akkuiskuporaruuvinväännin	Vakuutamme täten, että mainitut tuotteet vastaavat kaikkia seuraavien direktiivien ja asetusten asiaankuuluvia vaatimuksia ja ovat seuraavien standardien vaatimusten mukaisia. Tekniset asiakirjat saatavana: *
el	Δήλωση πιστότητας ΕΕ Δραπανοκατσάβιδο Αριθμός ευρετηρίου μπαταρίας Κρουστικό δράπανο μπαταρίας	Δηλώνουμε με αποκλειστική μας ευθύνη, ότι τα αναφερόμενα προϊόντα αντιστοιχούν σε όλες τις σχετικές διατάξεις των πιο κάτω αναφερόμενων οδηγιών και κανονισμών και ταυτίζονται με τα ακόλουθα πρότυπα. Τεχνικά έγγραφα στη: *
tr	AB Uygunluk beyanı Akülü delme/ Ürün kodu vidalama makinesi Akülü darbeli delme/ vidalama makinesi	Tek sorumlu olarak, tanımlanan ürünün aşağıdaki yönetmelik ve direktiflerin geçerli bütün hükümlerine ve aşağıdaki standartlara uygun olduğunu beyan ederiz. Teknik belgelerin bulunduğu yer: *
pl	Deklaracja zgodności UE Wiertarko-wkrętarka Numer katalogowy akumulatorowa Akumulatorowa wiertarko-wkrętarkaz udarem	Oświadczamy z pełną odpowiedzialnością, że niniejsze produkty odpowiadają wszystkim wymaganiom poniżej wyszczególnionych dyrektyw i rozporządzeń, oraz że są zgodne z następującymi normami. Dokumentacja techniczna: *
cs	EU prohlášení o shodě Akumulátorový vrtací Objednací číslo šroubovák Akumulátorový vrtací šroubovák s příklepem	Prohlašujeme na výhradní zodpovědnost, že uvedený výrobek splňuje všechna příslušná ustanovení níže uvedených směrnic a nařízení a je v souladu s následujícími normami: Technické podklady u: *
sk	EU vyhlásenie o zhode Akumulátorový vrtací Vecné číslo skrutkovač Akumulátorový príklepový vrtací skrutkovač	Vyhlasujeme na výhradnú zodpovednosť, že uvedený výrobok spĺňa všetky príslušné ustanovenia nižšie uvedených smerníc a nariadení a je v súlade s nasledujúcimi normami: Technické podklady má spoločnosť: *
hu	EU konformitási nyilatkozat Akumulátoros fűrő- Cikkszám és csavarozógép Akumulátoros ütve- fűrő-csavarozógép	Egyedüli felelősséggel kijelentjük, hogy a megnevezett termékek megfelelnek az alábbiakban felsorolásra kerülő irányelvek és rendeletek valamennyi idevágó előírásainak és megfelelnek a következő szabványoknak. Műszaki dokumentumok megőrzési pontja: *
ru	Заявление о соответствии ЕС Дрель-шурупверт Товарный № Аккумуляторный шурупверт ударного действия	Мы заявляем под нашу единоличную ответственность, что названные продукты соответствуют всем действующим предписаниям нижеуказанных директив и распоряжений, а также нижеуказанных норм. Техническая документация хранится у: *
uk	Заява про відповідність ЄС Акумуляторний Товарний номер дріль-шурупверт Акумуляторний ударний дріль-шурупверт	Ми заявляємо під нашу одноособову відповідальність, що названі вироби відповідають усім чинним положенням нижчеозначених директив і розпоряджень, а також нижчеозначеним нормам. Технічна документація зберігається у: *

III		CE
kk	EO сәйкестік мағлұмдамасы Аккумуляторлық Әнім нөмірі дрель-шуруп бұрауыш Аккумуляторлы перфоратор бұрғысы	Өз жауапкершілікпен біз аталған өнімдер төменде жазылған директикалар мен жарлықтардың тиісті қағидаларына сәйкестігін және төмендегі нормаларға сай екенін білдіреміз. Техникалық құжаттар: *
ro	Declarație de conformitate UE Mașină de găurit și Număr de înșurubat cu acumula- identificare tor Mașină de înșurubat și găurit cu percuție cu acumulator	Declarăm pe proprie răspundere că produsele menționate corespund tuturor dispozițiilor relevante ale directivelor și reglementărilor enumerate în cele ce urmează și sunt în conformitate cu următoarele standarde. Documentație tehnică la: *
bg	ЕС декларация за съответствие Акумулаторен Каталоген номер винтоверт Акумулаторен ударен винтоверт	С пълна отговорност ние декларираме, че посочените продукти отговарят на всички валидни изисквания на директивите и разпоредбите по-долу и съответства на следните стандарти. Техническа документация при: *
mk	EU-Изјава за сообразност Батериска дупчалка- Број на дел/артикул одвртувач Батериски ударни дупчалки- одвртувачи	Со целосна одговорност изјавуваме, дека опишаните производи се во согласност со сите релевантни одредби на следните регулативи и прописи и се во согласност со следните норми. Техничка документација кај: *
sr	EU-izjava o usaglašenosti Akku-bušilica-odvrtač Broj predmeta Akumulatorski uvrtač sa udarcima	Na sopstvenu odgovornost izjavljujemo, da navedeni proizvodi odgovaraju svim dotičnim odredbama naknadno navedenih smernica u uredaba i da su u skladu sa sledećim standardima. Tehnička dokumentacija kod: *
sl	Izjava o skladnosti ES Akumulatorski vrtalni Številka artikla vijačnik Akumulatorski udarni vijačnik	Izjavljamo pod izključno odgovornostjo, da je omenjen izdelek v skladu z vse-mi relevantnimi določili direktiv in uredb ter ustreza naslednjim standardom. Tehnična dokumentacija pri: *
hr	EU izjava o sukladnosti Aku bušilica i odvijač Kataloški br. Aku udarni odvijač	Pod punom odgovornošću izjavljujemo da navedeni proizvodi odgovaraju svim relevantnim odredbama direktiva i propisima navedenima u nastavku i da su sukladni sa sljedećim normama. Tehnička dokumentacija se može dobiti kod: *
et	EL-vastavusdeklaratsioon Akutrell-kruvikeeraja Tootenumber Akulöökpuurtrell- kruvikeeraja	Kinnitame ainuvastutajatena, et nimetatud tooted vastavad järgnevalt loetle-tud direktiivide ja määruste kõikidele asjaomastele nõuetele ja on kooskõlas järgmiste normidega. Tehnilised dokumendid saadaval: *
lv	Deklarācija par atbilstību EK standartiem Akumulatora Izstrādājuma urbjmašina – numurs skrūvgriezis Akumulatora triecienuurbjmašina – skrūvgriezis	Mēs ar pilnu atbildību paziņojam, ka šeit aplūkotie izstrādājumi atbilst visiem tālāk minētajās direktīvās un rīkojumos ietvertajām saistošajām nostādņēm, kā arī sekojošiem standartiem. Tehniskā dokumentācija no: *

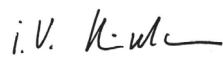
CE		IV	
lt ES atitikties deklaracija		Atsakingai pareiškiame, kad išvardyti gaminiai atitinka visus privalomus žemiau nurodytų direktyvų ir reglamentų reikalavimus ir šiuos standartus. Techninė dokumentacija saugoma: *	
Akumulatorinis gręžtuvas-suktuvus	Gaminio numeris		
Akumulatorinis smūginis gręžtuvas-suktuvus			
GSR 18V-60 C	3 601 JG1 1..	2006/42/EC 2014/30/EU	EN 60745-1:2009+A11:2010 EN 60745-2-1:2010
GSB 18V-60 C	3 601 JG2 1..	2011/65/EU 2009/125/EC (1194/2012)	EN 60745-2-2:2010 EN 55014-1:2006+A1:2009+A2:2011 EN 55014-2:1997+A1:2001+A2:2008 EN 50581:2012
		 BOSCH	* Robert Bosch Power Tools GmbH (PT/ECS) 70538 Stuttgart GERMANY
		Henk Becker Executive Vice President Engineering and Manufacturing	Helmut Heinzelmann Head of Product Certification
			
		Robert Bosch Power Tools GmbH, 70538 Stuttgart, GERMANY Stuttgart, 01.01.2017	