

RoHS Compliant

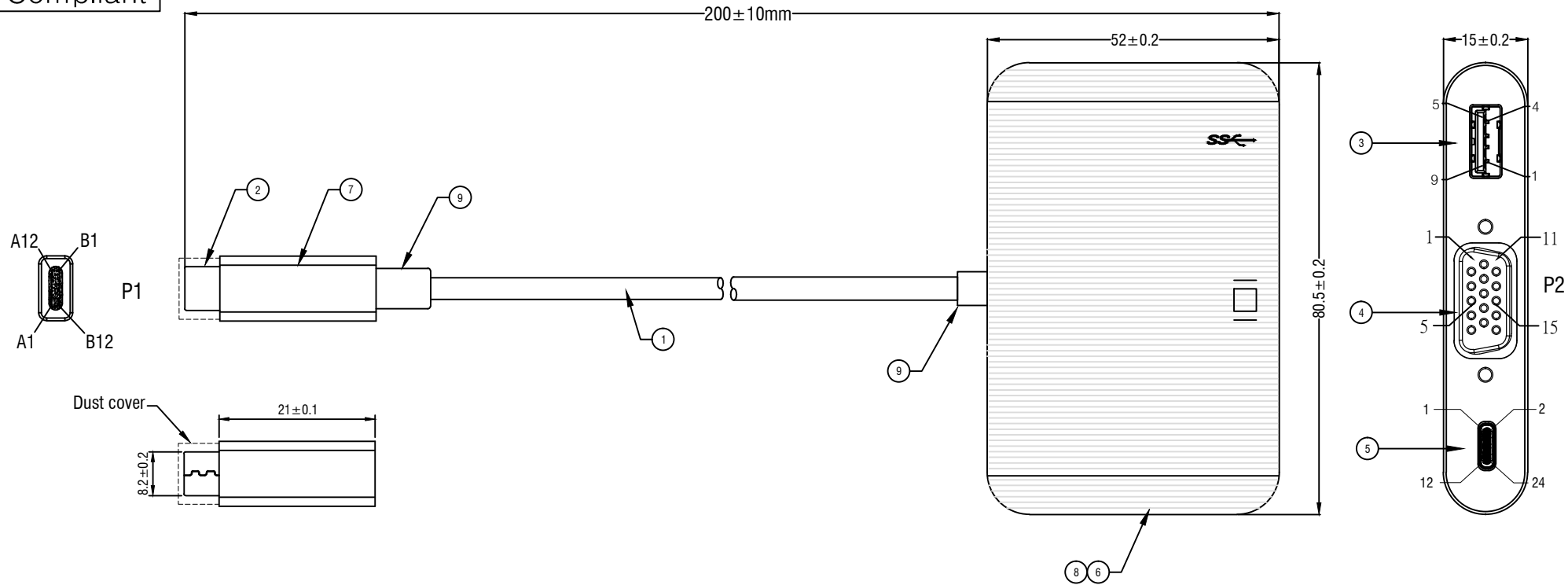

Electrical Test:

- 1.100% TEST OPEN SHORT MIS-WIRE.
- 2.CONTACT RESISTANCE:3Ω MAX.
- 3.INSULATION RESISTANCE:5MΩ MIN.
- 4.HI-POT:300V DC/10MS.
- 5.Real Test Passed 1920 * 1080P 60Hz.
- 6.Real Test Not Twinkling,Double Vision and Decolor.

NUMBER	PRODUCT SPECIFICATIONS	Quantity	Unit
9	BLACK 45P TPE		G
8	USB3.0 AF+HDB 15F+USB TYPE CF Black brushed aluminum shell	1	PCS
7	USB TYPE C MALE Black brushed aluminum shell	1	PCS
6	PCB	1	PCS
5	USB TYPE C FEMALE(Black Insulator Nickel Plated)	1	PCS
4	HDB 15P FEMALE(Blue Insulator Nickel Plated)	1	PCS
3	USB 3.0 A FEMALE(Blue Insulator Nickel Plated)	1	PCS
2	USB TYPE C MALE(Black Insulator Nickel Plated)	1	PCS
1	UL20276(32#*1P+D+AL/MY)*4+32#*6C+24#*2C+AL+B OD=4.6mm,BLACK PVC JACKET.	1	PCS

D		
C		
B		
VER.A	REVISE	DATE

Company: CONRAD		
Item		
Draw	Kobe	Date: 2016.07.29
Approval		
Maker	F16	
Sample NO.	29039c219	Drawings of 1 (1) Proportion: 1:1 Unit(mm)