

CONSTRUCTION MANUAL

Gear Assembly Set G494B, 1:494

Item no. **96751**

Conrad No. 1534271

Motor for micro-models, enclosed. Brass with steel axle, developed specifically for 1:87 lorries.

Originally developed as a motor for 1:87 lorries, this small gear unit is also excellently suited for light motors on larger vehicles. It can even be used to implement winches and special functions.

The G494B is an enclosed gear assembly set with a gear reduction of 1:494. Ideal for street and off-road lorries.

The gear assembly set is screwed together, so it can always be disassembled and is service-friendly. The G494B further has M1 mounting holes and can therefore be screwed to the vehicle frame. Because of its compact size the G494B can be built into the vehicle frame to even build tractor units. The gear unit comes as an assembly set.

Detailed illustrated instructions for easy assembly.

Gear assembly set G494B,
fully assembled

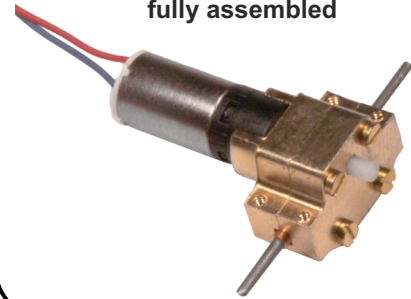

Mechanical data:	
Length	22 mm
Width (axle beam)	12 mm
Width (between frame sides)	8.5 mm
Height	9 mm
Height (axle to bottom edge)	4 mm
Weight	4.5
Ratio	1:494
Electrical data:	
Voltage:	3.7 V

Number:	Parts list:	Components:
1	Transmission G26	
2	Transmission halves	
1	Axis 24 mm	
1	Screw S15	
1	Gear Z19	
4	Screw M1x5	

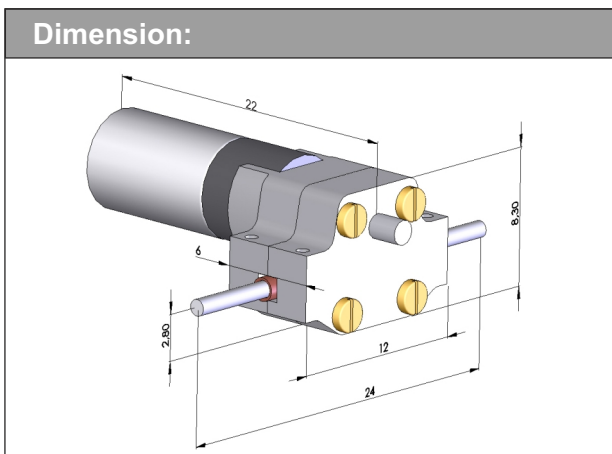

Gear Assembly Set G494B,
installed in a 1zu87 wheel loader

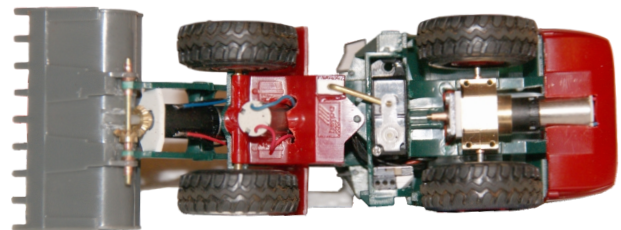

Note on constructing the gear assembly set:

- The metal parts should be deburred as necessary.
- Before soldering/gluing, clean and degrease the parts. When using adhesive, be sure to observe the indicated drying time.
- When soldering the cog to the axle, do not allow soldering tin to get into the teeth. The soldering point must be clean and free of grease. Remove any excess tin at the soldering point with the scalpel after soldering. Otherwise the copper sockets will not fit. The same applies to excess adhesives in cemented areas.
- First loosely fix the gear cover. Then start the motor at a low voltage. Whilst in operation, tighten the screws one by one. The performance of the motor indicates if certain parts are jamming or catching. After a short run-in period the gear should run smoothly in both directions.

CONSTRUCTION MANUAL

Gear Assembly Set G494B, 1:494

 Item no. **96751**

Motor for micro-models, enclosed. Brass with steel axle, developed specifically for 1:87 lorries.

Construction of the gear assembly set:

Push in the worm all the way in:

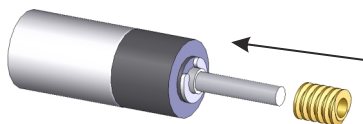
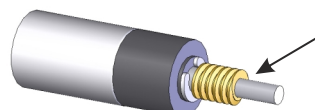
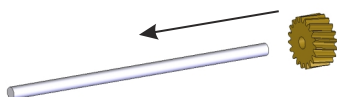
 Use superglue sparingly (*leave the glue to set per glue instructions*):

 Solder on the cog in the middle or cement in place with good metal adhesive (*leave the glue to set per glue instructions*):

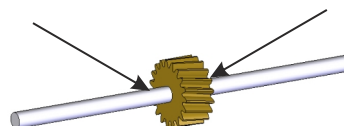
Remove excess tin / glue:

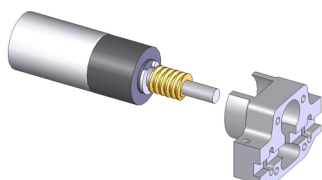
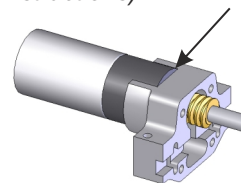

Mount the gearbox, slide the motor in all the way:

 Use superglue sparingly (*leave the glue to set per glue instructions*):

Slide on the copper bushings (must turn easily on the axle) then insert axle:

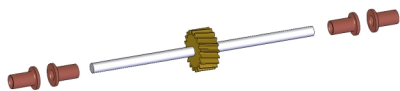

The axle should have minimum play (horizontal) in the uptake and not jam:

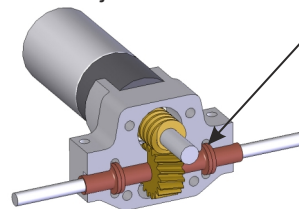

Screw on the gear cover loosely then tighten crosswise after running in:

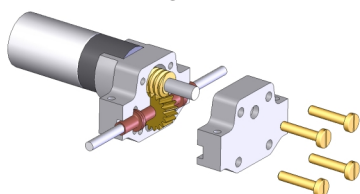

M1 thread for mounting in the chassis

