

**Professional all-in-one Weather Station**  
**Model: WMR500**  
**USER MANUAL**

**CONTENTS**

**Introduction**..... 1

**Packaging Contents** ..... 1

**All-in-one sensor** ..... 1

**Accessories - sensors** ..... 2

**Overview**..... 2

    Main unit..... 2

    Real and bottom view..... 2

    Lcd display ..... 2

    All-in-one sensor ..... 3

**Installation**..... 3

    Assemble the wind sensor ..... 3

    Remove The Tape On The Debris Collector ..... 3

    Power the base station..... 4

    Power the all-in-one sensor ..... 4

    Mounting the all-in-one sensor ..... 4

**Pairing the sensor** ..... 4

**Pair your smart device with the weather station** ..... 4

**Setting the clock time** ..... 4

**Moon phase**..... 4

**Weather forecast** ..... 4

**Temperature and humidity** ..... 5

    Temperature and humidity trend ..... 5

**Wind chill / direction / speed** ..... 5

**Uv/rainfall/ barometer/pmi** ..... 5

    Rainfall ..... 5

    Uv index (optional) ..... 5

    Barometer ..... 5

    Pmi (optional)..... 5

**Backlight** ..... 5

**Reset**..... 5

**Maintainance**..... 6

**Specifications** ..... 6

    Main Unit..... 6

    All-in-one sensor ..... 6

    Indoor barometer..... 6

    Indoor temperature..... 6

    Indoor relative humidity..... 6

    Outdoor temperature..... 6

    Outdoor relative humidity ..... 6

    Wind sensor ..... 6

    Rain gauge..... 6

**Precautions** ..... 6

**About Oregon Scientific** ..... 7

**EU-Declaration Of Conformity**..... 7

**FCC Statement** ..... 7

    Declaration of Conformity..... 7

**Information for users** ..... 7

**INTRODUCTION**

Thank you for selecting the Oregon Scientific™ Weather Station (WMR500). This product can provide you with weather information through an all-in-one sensor with high levels of accuracy. Download the dedicated app to set up your weather station and experience all of the features of the WMR500. The App remembers the data for a time range for you to monitor and analyze the weather status. The base station is compatible with other weather sensors. To purchase additional sensors, please contact your local retailer.

**NOTE**

Please read this user manual before using your product and keep it for future reference. For the complete operation instructions, please visit <http://global.oregonscientific.com/customerSupport.php>.

**PACKAGING CONTENTS**

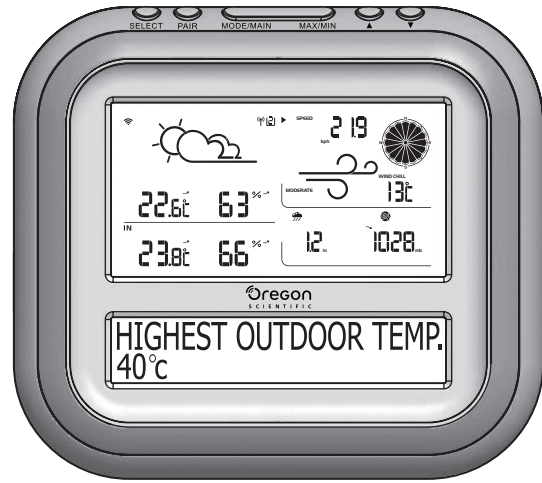

1 x Base Station



3 x AA UM-3 1.5V batteries

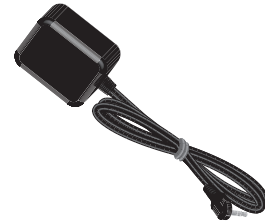

1x Power Adapter

**ALL-IN-ONE SENSOR**

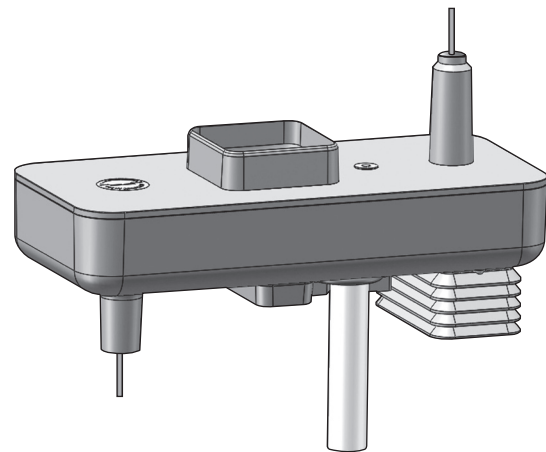

1x Main unit

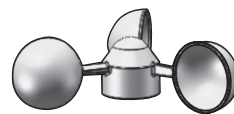

1x Wind cups

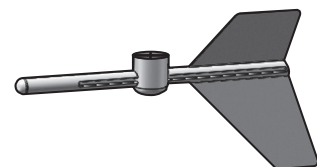

1x Wind vane

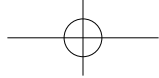

EN

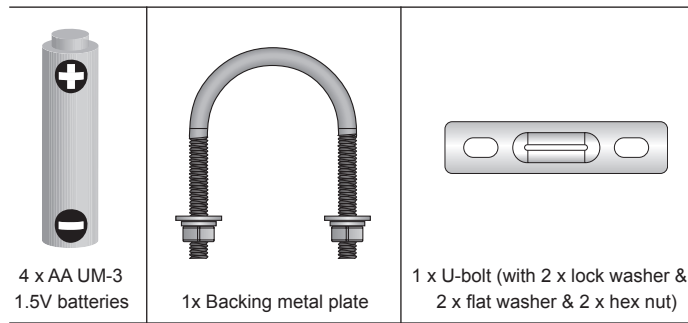

### ACCESSORIES - SENSORS

This product can work with other sensors to maximize the performance of your weather station.

Optional wireless remote sensors (Oregon Scientific brand) such as those listed below can be purchased separately. For more information, please contact your local retailer.\* Please visit our website at [www.oregonscientific.com](http://www.oregonscientific.com) for more details about these sensors.

- Dust sensor
- UV sensor (UV index)

\* Features and accessories will not be available in all countries.

### OVERVIEW

#### MAIN UNIT

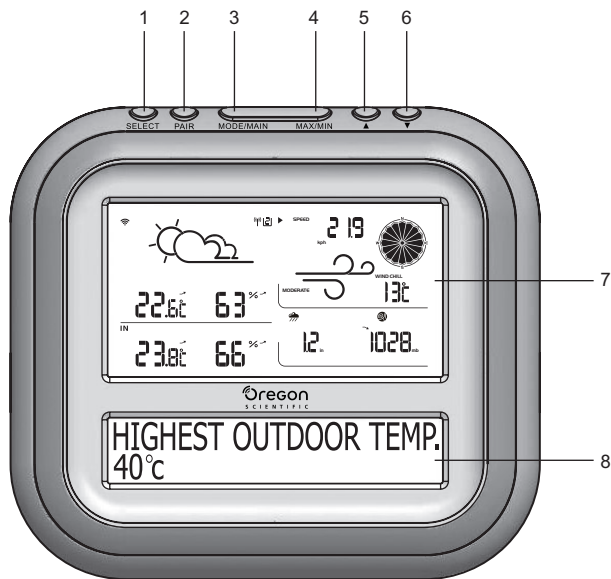

1. **SELECT**: Switch among the different areas
2. **PAIR**: Enter and confirm pairing mode
3. **MODE/MAIN**: Toggle among the different display modes
4. **MAX/MIN**: Read today max/min memory readings
5. **▲**: Increase value; toggle to browse outdoor channels; select pairing mode
6. **▼**: Decrease value; toggle to browse outdoor channels; remove sensor; select pairing mode
7. All weather information display area
8. Dot matrix display area

#### REAL AND BOTTOM VIEW

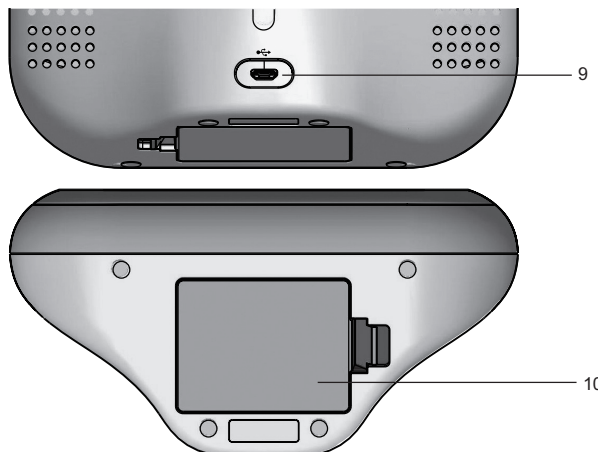

9. Micro USB power jack
10. Battery compartment

### LCD DISPLAY

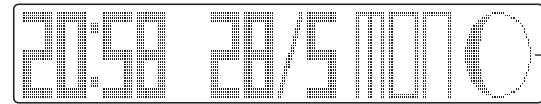
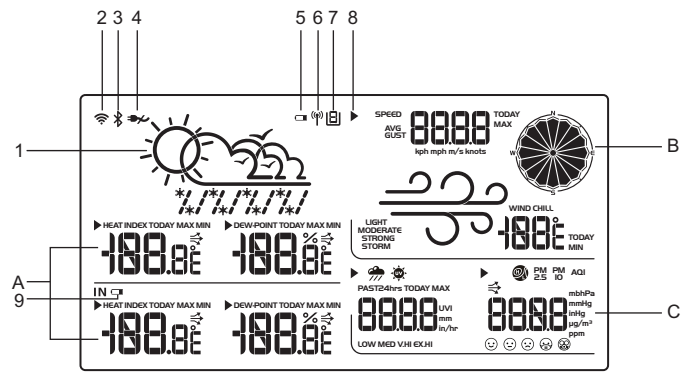

- A. Temperature/Heat Index /Humidity/Dew-point area
  - B. Wind speed/Wind direction/ Wind chill area
  - C. UV/ Rainfall / Barometric pressure/Air quality area
  - D. Alert message; Clock /Calendar/Weekday/Moon Phase area
1. Weather forecast
  2. Wi-Fi connection indicator
  3. Bluetooth indicator
  4. No main power supply
  5. Low battery indicator for the sensor
  6. Sensor searching indicator
  7. Sensor channel
  8. Selected area icon
  9. Low battery indicator for the base station

#### A Temperature/Heat Index /Humidity/Dew-point area

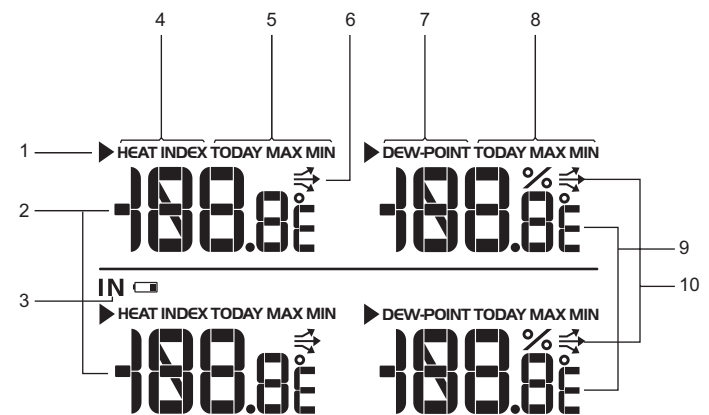

1. Selected area icon
2. Indoor/Outdoor temperature reading (°C for EU/°F for US)
3. Indoor temperature/humidity indicator
4. Heat index
5. Today Max/Min temperature/heat index
6. Temperature trend
7. Dew-point
8. Today Max/Min humidity/dew-point
9. Humidity /dew-point reading
10. Humidity trend

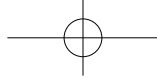

### B Wind speed/Wind direction/ Wind chill area

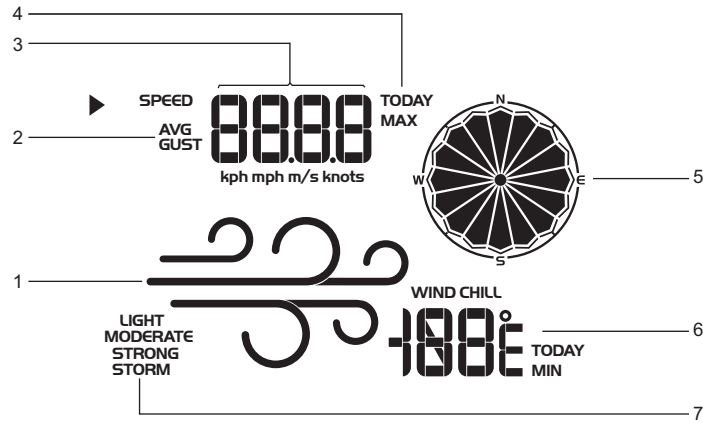

1. Wind speed level indicator
2. Wind speed indicator (AVG/GUST)
3. Wind speed reading (m/s, knots, kph or mph)
4. Today max wind speed memory
5. Wind direction indicator
6. Today minimum wind chill
7. Wind speed level description

### C UVI/ Rainfall area / Barometric pressure / Air quality area

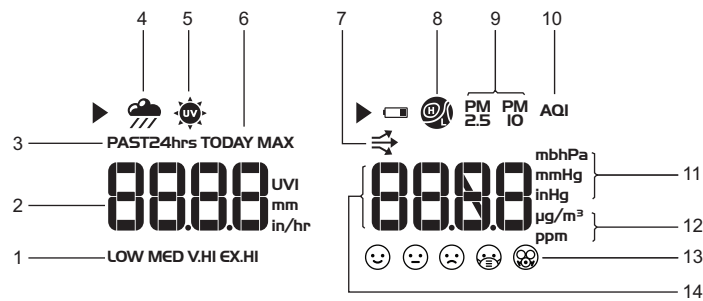

1. UVI level indicator
2. UVI/rainfall reading (UVI; mm; inch; mm/hr; in/hr)
3. Today/Past 24 hours rainfall
4. Rainfall/rain rate indicator
5. UVI indicator
6. Current/Max UVI or rain rate
7. Barometric pressure trend
8. Barometric pressure indicator
9. PM (Particle Matter) reading indicator
10. AQI (Air quality index)
11. Barometric pressure unit (mb/hPa/mmHg/inHg)
12. PM2.5/PM10 unit ( $\mu\text{g}/\text{m}^3/\text{ppm}$ )
13. AQI level indicator
14. Barometric pressure /PPM reading

### D Clock /Calender/Weekday/Moon Phase area

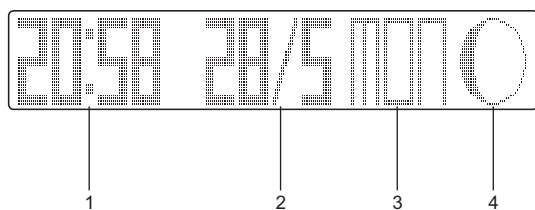

1. Clock
2. Date
3. Weekday
4. Moon phase

### ALL-IN-ONE SENSOR

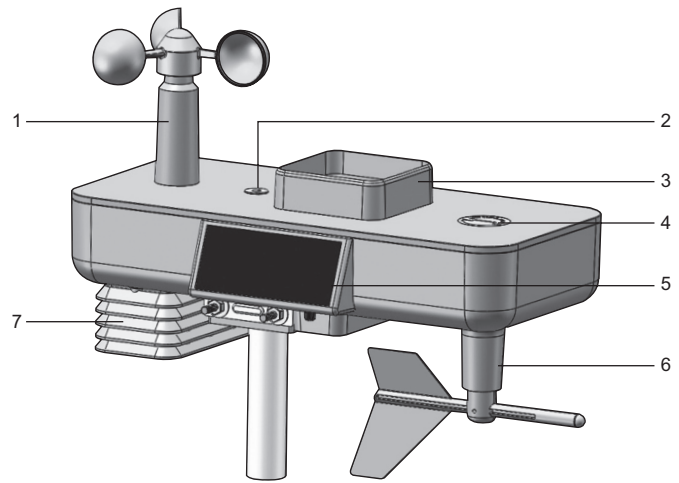

1. Wind speed sensor: Measures wind speed
2. Level indicator: Indicates whether the sensor is level or needs adjustment
3. Rain gauge with collector: Takes rainfall readings/ Collects rain
4. UV sensor (not included) location: Take UV readings
5. Solar panel: Provide power to the sensor and prolongs battery life
6. Wind direction vane: Takes wind direction
7. Dust sensor (not included) location: Take PM 2.5/PM 10 readings
8. Temperature/Humidity sensor (not shown): Measures temperature and humidity readings

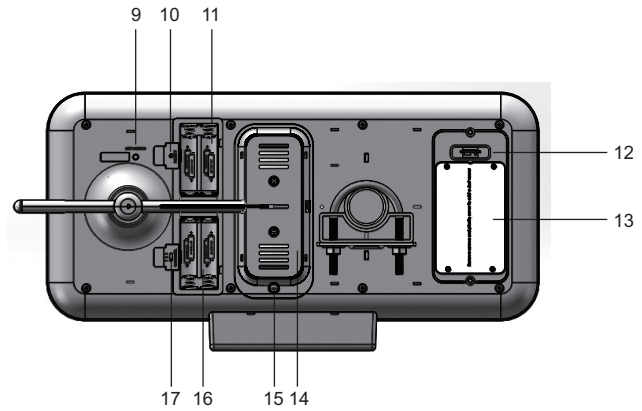

9. **SET NORTH:** Calibrate the direction of wind sensor
10. **RESET:** Returns unit to default settings
11. Battery compartment for the all-in-one sensor
12. Temperature/Humidity sensor location
13. Dust sensor location (optional)
14. Debris collector
15. Screw to open/close the debris collector
16. Battery compartment for dust sensor (optional)
17. **CHANNEL 1, 2, 3:** Select sensor channel

### INSTALLATION

#### ASSEMBLE THE WIND SENSOR

1. Loosen the screws in the wind cups and wind vane.
2. Insert the top of the wind sensor unit into the wind cups securely with some pressure and then twist the screw tightly.
3. Insert the bottom of the wind sensor unit into the wind vane securely with some pressure and then twist the screw tightly.

#### REMOVE THE TAPE ON THE DEBRIS COLLECTOR

A debris collector is located under the rain collector and fixed by fiber tape. Unscrew it and remove the tape before first time using.

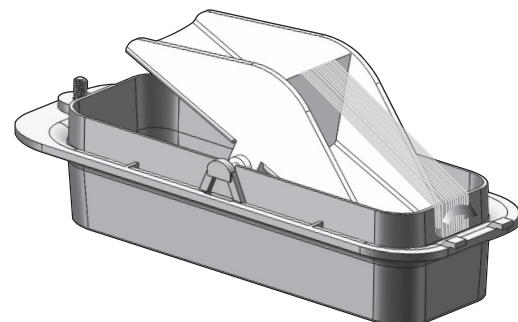

## POWER THE BASE STATION

Insert the 3 AA batteries (included) to the battery compartment of the base station for back-up usage, matching the polarity symbols (+ and -) marked inside.

Connect the supplied power adapter to the Micro USB power jack, then plug into a standard AC outlet.

## POWER THE ALL-IN-ONE SENSOR

Insert the 4 AA batteries (included) to the **MAIN UNIT** battery compartment, matching the polarity symbols (+ and -) marked inside.

(Optional) Install 4 AA batteries (not included) to the **DUST SENSOR** battery compartment for back-up usage, matching the polarity symbols (+ and -) marked inside.

### NOTE

- If you will be connecting more than one all-in-one sensor, slide the channel switch **CHANNEL 1, 2, 3** to select another channel before replace the battery compartment cover.
- For longer performance, recommend to use alkaline batteries and consumer grade lithium batteries in temperatures below freezing.
- Replace the batteries when  displays on the base station. Press **RESET** after each battery replacement.
- The power adapter is intended to be correctly oriented in a vertical or floor mount position. The prongs are not designed to hold the plug in place if it is plugged into a ceiling, under-the-table or cabinet outlet. The socket-outlet shall be installed near the equipment and shall be easily accessible.

## MOUNTING THE ALL-IN-ONE SENSOR

The sensor is capable of transmitting data to the base station wirelessly within an approximate operating range of 300 m (1000 feet). Ideal locations for the sensor would be in any location on the roof of a building that is in an open area away from trees or other obstructions preventing from the wind flow for an accurate reading. Additionally, locate the sensor in direct sunlight for optimal power supply to the solar panel.

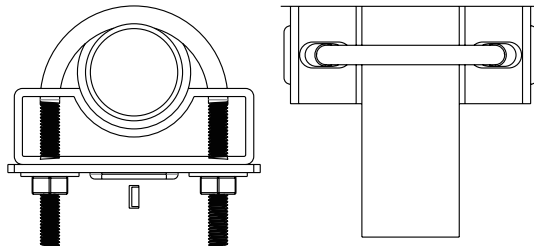

Solar panel facing:	If you reside in the:
North	Southern Hemisphere
South	Northern Hemisphere

### Secure the all-in-one sensor connector in the desired location:

- Align the back of the sensor connector to an existing pole.
- Secure in place by inserting the ends of the U-bolt into the holes on the sensor connector and securing it with washers and bolts.
- Securely locate the pole in your desired outdoor area.

### NOTE

- Make sure the water bubble in the level indicator on the top surface stays within the circle. Check the balance status regularly for an accurate rainfall rate reading.
- Ensure the wind sensor is pointing North to enable it be record accurate readings. Press **SET NORTH**  at the bottom of the sensor to calibrate the direction. You can use a compass to look for an accurate direction of north if necessary.
- Press **RESET** button on the main unit to erase all testing data.

## PAIRING THE SENSOR

- Press and hold **PAIR** for 3 seconds on the base station, two pairing options will display on the dot matrix display area.
  - Wi-Fi joining
  - All-in-one sensor pairing
- Press **▲** or **▼** to select "All-in-one sensor pairing", then press **PAIR** to confirm.  will flash on the display and the base station starts to search for the sensor. When successfully paired, the channel no. and weather contents will show on the LCD display.

### To add a new sensor or replace the sensor

- Slide the channel switch to select a channel.
- Power up or press **RESET** on the new sensor.
- Follow the above pairing steps 1-2 to pair the new sensor.

### To remove a sensor

- Press **SELECT** repeatedly to navigate  icon to the outdoor temperature/heat index/dew-point area.
- Press **▲** or **▼** to select a sensor channel. Press and hold **▼** for 3 seconds to remove/disconnect the specific sensor (channel).

### NOTE

- Complete the pairing within 30 minutes after you power up or reset the sensor. Otherwise, the base station will stop searching the sensor.
- To replace a specific sensor, remove it before replacing.
- If the new sensor is successfully paired, the new channel number and weather contents will display. Otherwise, the base station will still display the data from the old sensor.
- If the base station cannot receive the weather data from the sensor, or "- -" displays as the data value. Press and hold **PAIR** to search the sensor again.
  - "- -" means lost link.
  - "NA" means data not available or data cannot be calculated.

## PAIR YOUR SMART DEVICE WITH THE WEATHER STATION

You can view the weather contents and weather forecast, set the altitude, select the display units, and review the history data by monthly, weekly, daily and hourly from different sensor channel on the App.

### Download the App

Scan the QR code or search "**Oregon Scientific Smart Living**"  to find the App and download on your smart device. The App is available on both Apple App Store and Google Play.

### Join the Wi-Fi network

- Make sure your Wi-Fi network is on and your smart device is Wi-Fi connected.
- Open the App, follow the screen instructions to register an account and log in.
- Press and hold **PAIR** for 3 seconds to enter pairing mode, select "Wi-Fi joining", then press **PAIR** to confirm. The weather station starts to search the Wi-Fi network.
- A message "Wait wifi setting" displays on the dot matrix display area, then tap **START CONFIG** on your smart device. "Join wifi..." will display.
- After successfully paired, a message "WIFI CONNECTING SUCCESS!" appears. The channel number,  icon and the weather information will show on the LCD display. The current clock time/date/weekday/moon phase will be displayed.
- Tap **BIND DEVICE** on your smart device to bind your smart device with the weather station.

**NOTE** Always keep Wi-Fi connected for the weather station to store data to the server.









## SETTING THE CLOCK TIME

The main unit will automatically synchronize the clock time when connected with our server and App via Wi-Fi.

You can also set the language (English, French, German, Italian, Spanish), time zone (-12 to 14) and hour format (12/24 hr) on the App.

## MOON PHASE





Following icons illustrate how the moon will appear on the base station.

	New Moon		Full Moon
	Waxing Crescent		Waning Gibbous
	First quarter		Third quarter
	Waxing Gibbous		Waning Crescent

**NOTE** The moon phase displays in opposite orientation if you are in southern hemisphere.

## WEATHER FORECAST

The weather station displays the current weather within a 30-50 km (19-31 mile) radius. You can view the weather forecast for 7 days on App.

ICON	DESCRIPTION
	Sunny
	Partly cloudy
	Cloudy
	Rainy
	Snowy

## TEMPERATURE AND HUMIDITY

You can view the current indoor/outdoor temperature/heat index, humidity, dew-point and the max/min memories on the base station.  
Select the temperature unit on App: °C (for EU)/°F (for US).

**To view current temperature, heat index and TODAY MAX/MIN readings on the device:**

1. Press **SELECT** repeatedly to navigate  icon to the temperature/heat index area.
2. Press **MODE** repeatedly to toggle between the temperature/heat index displays.
3. Press **MAX / MIN** to toggle among current / MAX /MIN readings.
4. Press **▲** or **▼** to change channel (outdoor temperature only).

**To view humidity, TODAY MAX/MIN and dew-point readings on the device:**

1. Press **SELECT** repeatedly to navigate  icon to the humidity/dew-point area.
2. Press **MODE** repeatedly to toggle between the humidity/dew-point displays.
3. Press **MAX / MIN** to toggle among current/MAX/MIN readings.

**NOTE** The heat index provides an indication on how hot it feels based on air temperature and relative humidity.

**NOTE** The dew point advises at what temperature condensation will form.

## TEMPERATURE AND HUMIDITY TREND

The trend lines are shown next to the temperature and humidity readings. The trend is shown as follows:

RISING	STEADY	FALLING
		

## WIND CHILL / DIRECTION / SPEED

You can view and set the numeric wind speed with maximum memory display on our dedicated App.

Select the wind units on the App.

- Kilometers per hour (**kph**)
- Miles per hour (**mph**)
- Meters per second (**m/s**)
- Knots (**knots**)

**View on the device:**

The base station provides wind speed and wind direction information.

To read the wind direction, find the compass point  is pointing to.

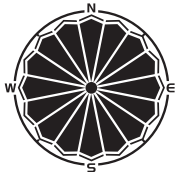

**To select wind display mode:**



Press **MODE** on wind area to toggle between:

- **GUST** (Gust)
- **AVG** (Average)

The wind level is shown by a series of text icon:

LIGHT	MODERATE	STRONG	STORM
2 -8 mph (3-13 km/h)	9-25 mph (14-41 km/h)	26-54 mph (42-87 km/h)	>55 mph (>88 km/h)

**To read the wind direction:**

Status	Wind Direction Indicator	Meaning
<b>GUST</b>		Real-time wind direction
<b>AVG</b>		Real-time average wind direction
<b>AVG</b>	} (Max 6 sets)	Wind direction of last hour

**To view today maximum wind speed and minimum wind chill readings:**

1. Press **SELECT** repeatedly to navigate  icon to the wind speed/wind direction/wind chill area.
2. Press **MAX / MIN** to toggle between current/MAX wind speed and current/MIN wind chill readings.



**NOTE** The wind chill factor is based on the combined effects of temperature and wind speed.

## UV/RAINFALL/ BAROMETRIC PRESSURE/PM

The station is capable of displaying the UV index, the current or last 24 hours of rainfall, max rain rate, barometric pressure and air quality readings.

### RAINFALL

**To view the recorded rainfall/rain rate of the current hour or last 24 hours:**



1. Press **SELECT** repeatedly to navigate  icon to the UV/Rainfall area.
2. Press **MODE** repeatedly to select .
3. Press **MAX / MIN** repeatedly to toggle among current / max rain rate, past 24 hours, or today accumulated rainfall readings.

**Select the measurement unit for the rainfall/rain rate on the App:**

- **mm** (millimeter); **in** (inch)
- **mm/hr** (millimeter per hour); **In/hr** (inch per hour)

### UV INDEX (OPTIONAL)

**To view the UV reading:**

1. Press **SELECT** repeatedly to navigate  icon to the UV/rainfall area.
2. Press **MODE** repeatedly to select .
3. Press **MAX / MIN** to toggle between current/MAX UV index display.

### BAROMETRIC PRESSURE

**To view the barometric pressure reading:**

1. Press **SELECT** repeatedly to navigate  icon to the barometric pressure/PM area.
2. Press **MODE** repeatedly to select .

**To view pressure trend:**

The barometric pressure trend icons are based on recent sensor readings.

The trend lines are shown next to the pressure readings. The trend is shown as follows:

RISING	STEADY	FALLING
		

**Select the measurement unit for the barometer on the App:**

- Barometric pressure: **mmHg** (Millimeters of mercury)
- **inHg** (inches of mercury), **mbar** (millibars)
- **hPa** (hectopascal).

**Set the altitude level compensation:**

The altitude reflects the distance from sea level at your position. You can set the altitude level compensation for the barometric pressure readings on the App.

**NOTE** When altitude is set to 0 meter, the pressure reading is the local pressure. If the altitude is set to the current location, the new pressure reading is an offset pressure to the sea level.





### PM (OPTIONAL)

**To view the PM reading:**

1. Press **SELECT** repeatedly to navigate  icon to the Barometric pressure/PM area.
2. Press **MODE** repeatedly to select **PM 2.5, PM10, AQI**.

**Select the measurement unit for the PM on the App:**

- **ppm**=( $\mu\text{g}/\text{m}^3$  value) (24.45)/(molecular weight)
- **$\mu\text{g}/\text{m}^3$** = (ppm value) (molecular weight)/24.5

Indicator	Index	Grade	Description
	0-50	1	Good
	51-100	2	Moderate
	101-150	3	Lightly polluted
	151-200	4	Moderately polluted
	201-300	5	Heavily polluted

### BACKLIGHT

Press any button on the base station to activate the backlight.

### RESET

Press **RESET** to return to the default settings.

**NOTE** You need take off the battery compartment cover to do pressing.

**MAINTAINANCE****Maintain the Rain Gauge**

Clean the hole of the rain collector and the debris collector for maintaining accuracy is very important. Unscrew the debris collector and clean the dirt by water periodically.

**Maintain the Wind Sensor**

If the wind cup doesn't spin in the wind or does not spin as fast as they should. Remove the wind cup and clear out all bugs, spider webs or debris.

**NOTE** Do not apply any fluid lubricant on the shaft and bearing. It probably breaks the inner electronic components.

**SPECIFICATIONS****BASE STATION**

Dimension (L x W x H)	180 x 90 x 160 mm (7 x 3.54 x 6.3 inches)
Weight	427.5 g (0.94 lbs) without battery
Battery	4 x 1.5 V AA batteries
AC/DC Adaptor	Input: 100-240 V, 50-60 Hz 300 mA Output: DC 5V, 1000 mA

**ALL-IN-ONE SENSOR**

Dimension (L x W x H)	385 x 195 x 315 mm (15.16 x 7.68 x 12.4 inches)
Weight	1139 g (2.51 lbs) without battery
RF transmission frequency	EU: 868mhz, US: 915mhz
No. of channel	3
RF transmission range	250 - 300 m (internal antenna)
Transmission Cycle	15 seconds
Battery	4 x 1.5 V AA + 4 x 1.5 V AA (optional for dust sensor)
Battery life	with dust sensor: 6 months (8 x 1.5 V AA) without dust sensor: 12 months (4 x 1.5 V AA)

**BAROMETRIC PRESSURE**

Unit	mb, inHg, mmHg and hPa
Measuring range	700 – 1050 hPa
Accuracy	+/- 7 hPa
Altitude setting	Sea level User setting for offset pressure to sea level
Weather display	Sunny, Partly Cloudy, Cloudy, Rainy and Snowy

**INDOOR TEMPERATURE**

Temperature unit	°C / °F (°C for EU, °F for US)
Measuring Range	-5 to 50 °C (23 – 122 °F)
Accuracy	0 – 40 °C (32 – 104 °F): +/-1 °C (+/- 2 °F) -5 to 0 °C (23 – 32.0 °F): +/-2 °C (+/- 4 °F) 40 – 50 °C (104 – 122 °F): +/-2 °C (+/- 4 °F)
Resolution	0.1 °C or 0.1 °F (remark: 0.1 °F convert from 0.1 °C display)
Memory	Current, Min. and Max.

**RELATIVE HUMIDITY**

Measuring Range	25% - 90% RH
Accuracy	40% - 80%RH: +/-5% RH 25% - 40%RH and 80%- 90%RH: +/-7% RH
Resolution	1%
Memory	Current, Min and Max

**OUTDOOR TEMPERATURE**

Temp. unit	°C / °F (°C for EU, °F for US)
Measuring Range	-30 to 60°C (-22 to 140°F)
Accuracy	-20 to 0 °C: +/-2.0°C (+/- 4.0°F) 0 – 40°C: +/-1.0°C (+/- 2.0°F) 40 – 50°C: +/-2.0°C (+/- 4.0°F) 50 – 60°C: +/- 3.0°C (+/- 6.0°F)
Temperature resolution	0.1°C (0.2°F)
Memory	Current, Min and Max

**WIND SENSOR**

Wind speed unit	m/s, knots, kph, mph
Speed accuracy	2 - 10 m/s (+/-2 m/s) 10 - 56 m/s (+/-10%)
Direction resolution	22.5 degree
Memory	Max wind speed

**RAIN GAUGE**

Rainfall unit	mm , inch (mm for EU, inch for US)
Rain rate unit	mm/hr and inch/hr
Measuring range for rainfall	0 mm to 9999 mm (0-393.6 inches)
Measuring range for rain rate	0, 0.04 in/hr (1mm/hr) to 40 in/hr (1016 mm/hr)
Accuracy	0 - 15 mm (0 - 0.6")/hr : +/- 1 mm/hr (0.04") 15 - 991 mm/hr (0.6 - 39") : +/- 10 %
Memory	Past 24 hrs, hourly from last memory reset

**PRECAUTIONS**

- Use only fresh batteries of the required size and type. Do not mix old and new batteries, different types of batteries.
- Do not dispose old batteries as unsorted municipal waste. Collection of such waste separately for special treatment is necessary.
- If you do not plan to use the product for a long time, remove the batteries. Batteries can leak chemicals that can damage electronic parts.
- Do not subject the device to excessive force, shock, dust, temperature or humidity.
- Do not immerse the device in water. If you spill liquid over it, dry it immediately with a soft, lint-free cloth.
- Do not clean the device with abrasive or corrosive materials.
- Do not tamper with the device's internal components. Doing so invalidates the warranty.
- Images shown in this manual may differ from the actual display.
- When disposing of this product, ensure it is collected separately for special treatment.
- The contents of this manual may not be reproduced without the permission of the manufacturer.

**NOTE** The technical specifications for this product and the contents of the user manual are subject to change without notice.

**NOTE** Features and accessories will not be available in all countries. For more information, please contact your local retailer. To download an electronic version of the user manual, please visit <http://global.oregonscientific.com/customerSupport.php>.

## ABOUT OREGON SCIENTIFIC

Visit our website [www.oregonscientific.com](http://www.oregonscientific.com) to learn more about Oregon Scientific products.



For any inquiry, please contact our Customer Services at [info@oregonscientific.com](mailto:info@oregonscientific.com). Oregon Scientific Global Distribution Limited reserves the right to interpret and construe any contents, terms and provisions in this user manual and to amend it, at its sole discretion, at any time without prior notice. To the extent that there is any inconsistency between the English version and any other language versions, the English version shall prevail.

## EU-DECLARATION OF CONFORMITY

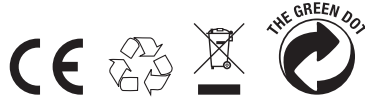
Hereby, IDT Technology Limited, declares that Professional all-in-one Weather Station (model: WMR500) is in compliance with the essential requirements and other relevant provisions of Directive RED 2014/53/UE. A copy of the signed and dated Declaration of Conformity is available on request via our Oregon Scientific Customer Service.



### COUNTRIES RED APPROVAL COMPLIED

All EU countries, Switzerland   
and Norway 

## FCC STATEMENT

This device complies with Part 15 of the FCC Rules. Operation is subject to the following two conditions: (1) This device may not cause harmful interference, and (2) This device must accept any interference received, including interference

**WARNING** Changes or modifications not expressly approved by the party responsible for compliance could void the user's authority to operate the equipment.

**NOTE** This equipment has been tested and found to comply with the limits for a Class B digital device, pursuant to Part 15 of the FCC Rules. These limits are designed to provide reasonable protection against harmful interference in a residential installation.

This equipment generates, uses and can radiate radio frequency energy and, if not installed and used in accordance with the instructions, may cause harmful interference to radio communications. However, there is no guarantee that interference will not occur in a particular installation. If this equipment does cause harmful interference to radio or television reception, which can be determined by turning the equipment off and on, the user is encouraged to try to correct the interference by one or more of the following measures:

- Reorient or relocate the receiving antenna.
- Increase the separation between the equipment and receiver.
- Connect the equipment into an outlet on a circuit different from that to which the receiver is connected.
- Consult the dealer or an experienced radio / TV technician for help.

## DECLARATION OF CONFORMITY

The following information is not to be used as contact for support or sales. Please call our customer service number (listed on our website at [www.oregonscientific.com](http://www.oregonscientific.com)), or on the warranty card for this product) for all inquiries instead.

**We**

Name: Oregon Scientific, Inc.  
Address: 10778 SW Manhasset Dr.  
DEVICE B-2 Tualatin,  
Or 97062 USA  
Telephone No.: 1-800-853-8883

### declare that the product

Product No.: WMR500  
Product Name: Professional all-in-one Weather Station  
Manufacturer: IDT Technology Limited  
Address: Block C, 9/F, Kaiser Estate,  
Phase 1, 41 Man Yue St.,  
Hung Hom, Kowloon,  
Hong Kong

## INFORMATION FOR USERS



Pursuant to and in accordance with Article 14 of the Directive 2012/19/EU of the European Parliament on waste electrical and electronic equipment (WEEE), and pursuant to and in accordance with Article 20 of the Directive 2006/66/EC of the European Parliament on batteries and accumulators and waste batteries.

The barred symbol of the rubbish bin shown on the equipment indicates that, at the end of its useful life, the product must be collected separately from other waste.

Please note that the batteries/rechargeable batteries must be removed from the equipment before it is given as waste. To remove the batteries/accumulators refer to the specifications in the user manual. Therefore, any products that have reached the end of their useful life must be given to waste disposal centers specializing in separate collection of waste electrical and electronic equipment, or given back to

the dealer when purchasing a new WEEE, pursuant to and in accordance with Article 14 as implemented in the country.

The adequate separate collection for the subsequent start-up of the equipment sent to be recycled, treated and disposal of in an environmentally compatible way contributes to preventing possible negative effects on the environment and

health and optimizes the recycling and reuse of components making up the apparatus. Abusive disposal of the product by the user involves application of the administrative sanctions according to the laws in force.