



Makeblock Co., Ltd.

Address: 4th Floor, Building C3, Nanshan iPark, No.1001 Xueyuan Avenue,
Nanshan District, Shenzhen, Guangdong Province, China

Technical support: support@makeblock.com

www.makeblock.com



Airblock

Modular&Programmable Drone

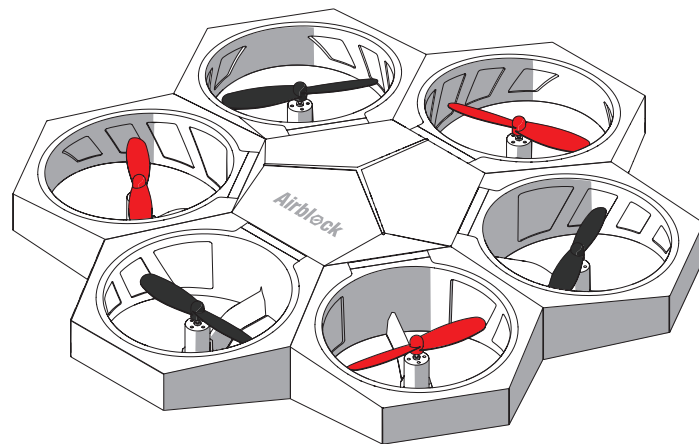

USER MANUAL

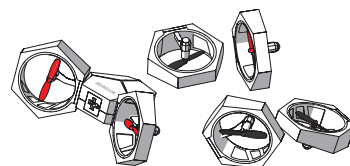
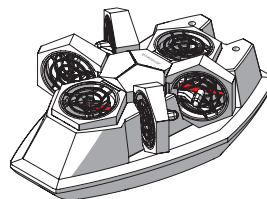

Table of Contents

P02 **Software Download**

P03 **Parts List**

P04 **Introduction to Main Control Module**

P05 **Introduction to Battery**

P06 **Introduction to Power Module**

P10 **Introduction to Stickers**

P12 **User Guide to Aircraft Mode**

· Operating Environment · Warning
· Installation Steps · Control

P18 **User Guide to Hovercraft Mode**

· Operating Environment · Warning
· Installation Steps · Control

P27 **User Guide to Custom Mode**

· Operating Methods · Operating Environment
· Warning · Programming

P30 **FAQs**

Software Download

A tablet or smartphone is required to control the Airblock.



Download from App Store

Search "Makeblock" and install the application from app store.

Download from Official Website

<http://learn.makeblock.com/en/software/>

Login to download the corresponding version.

System and Device Requirements

For iOS Devices: Requires iOS 9.0 or later versions. Compatible with iPhone5, iPad mini, iPad 3 or later models. For Android Devices: Requires Android 4.3 or later versions.

Apple, the Apple logo, iPad and iPhone are trademarks of Apple Inc, registered in the U.S. and other countries.

App Store is a service mark of Apple Inc.

Android and the Google logo are trademarks of Google Inc.

Parts List

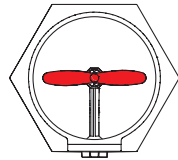
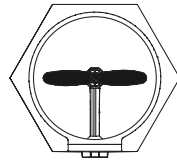
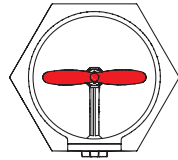
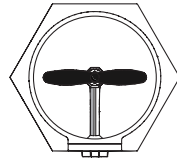
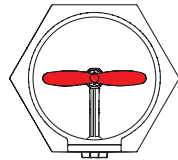
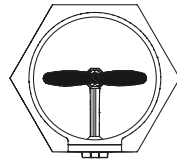
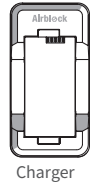
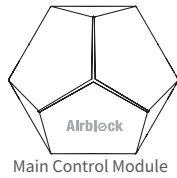

Power Modules

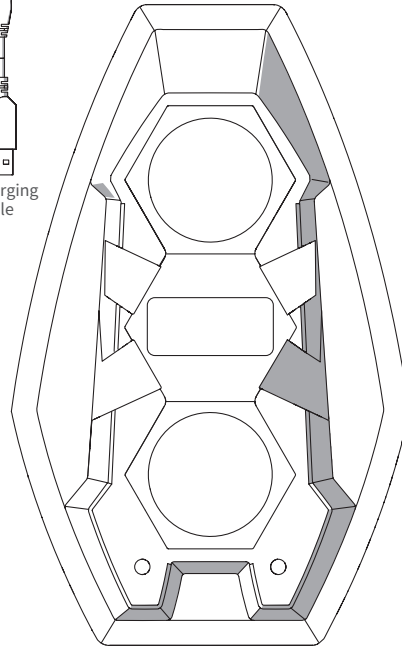

Hovercraft Base

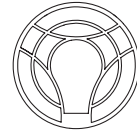
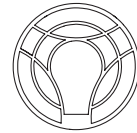

Protective Cover

User Guide to Aircraft Mode

The main control module includes 6 power module plug-in sockets, 3 LEDs, an ultrasonic sensor, a barometer, a gyroscope, Bluetooth, a microcontroller chip, etc.

Ultrasonic sensor is used for distance measurement. Works together with barometer to measure height change of the aircraft.

LED works as power supply indicator. Brightness and color is adjustable through programming.

The following are built-in sensors:

Barometer can sense height changes.

Gyroscope can sense position and orientation of the main control module.

Bluetooth module can establish connection with tablets or smartphones. Application program can read the real-time data collected by sensors.

Front View

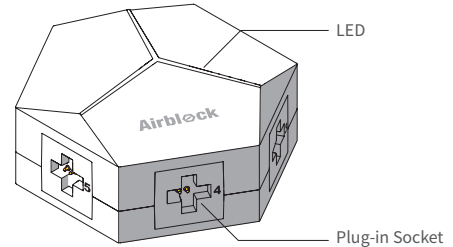

Back View

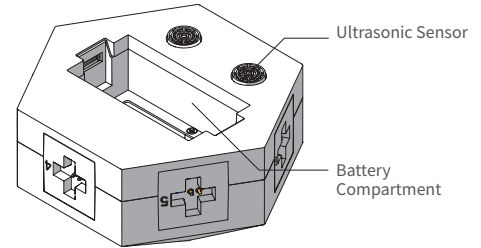

Battery

Airblock does not have a power switch. When a fully charged battery is inserted into the main controller, the controller automatically enters standby mode.

When inserting battery into main control module or battery charger, please ensure that the contact points are placed in the correct direction.

A red light indicates that charging is ongoing. A green light indicates that the battery is fully charged.

Warning:

- If unused for an extended period, battery should be removed from the main control module, and charged for half an hour before safekeeping to prevent damage due to overdischarging.
- Do not charge the battery for more than 12 hours.
- Do not use battery in high temperature or high humidity environment. Battery failure and explosion may be caused by battery impact.
- Electric wires, plugs, cases and other assembly units must be checked regularly whether they are damaged or not. Do not use it if there is any damage until it has been fully repaired.
- Battery types which can be used: Airblock special rechargeable lithium battery.
 - a. Rechargeable battery must be used under adults' supervision.
 - b. Rechargeable battery should be removed from the product before charging.
 - c. The battery should be put in with the correct polarity.
 - d. Exhausted battery should be removed from the main control module.
- Power terminal shall not short-circuit.

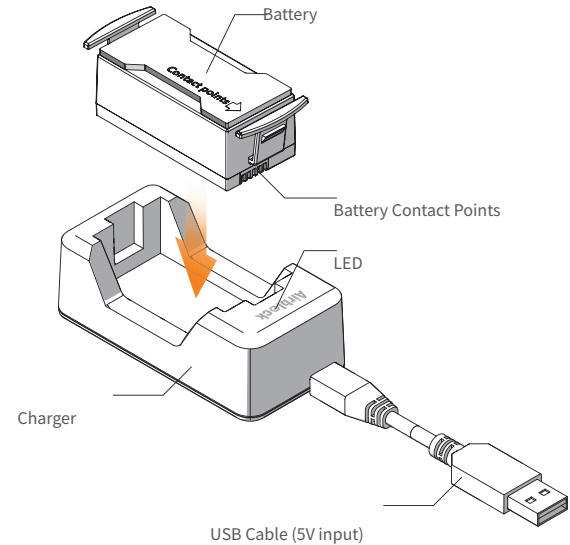

Power Module

Introduction to structure

The Power Module includes a motor, a propeller, a plug, a frame, etc.

LED is installed on the frame. LED lights up when the motor is activated.

LED on aircraft front power module and foot pad are red.
Foot pads on other power modules are black. LED as indicators are green.

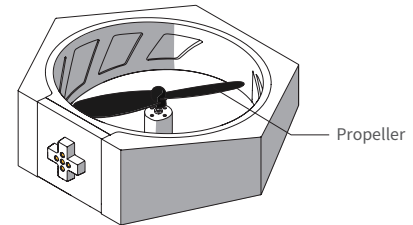
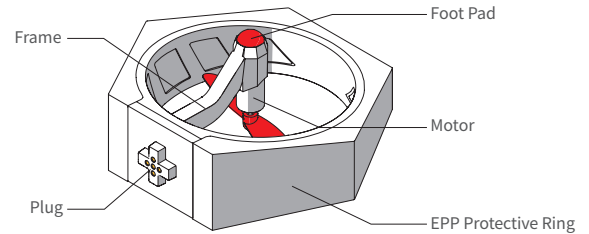

Power Module

Introduction to Operating Principles

In order to offset the self-rotation of the aircraft, the propellers are classified in red (counter-clockwise rotation) and black (clockwise rotation). Motors are also classified as clockwise and counter-clockwise rotation. After connecting to main control module, the motor starts spinning and pushes air downwards to generate an upward thrust.

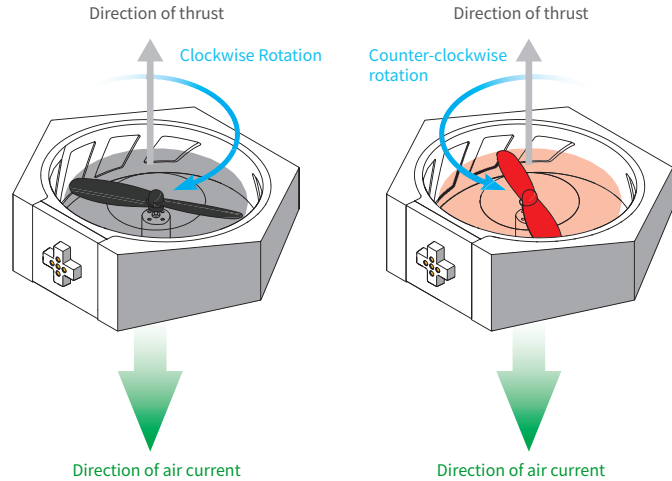

Power Module

Installation Angle

Each power module may be installed onto its corresponding port on the main control module at 4 different angles.

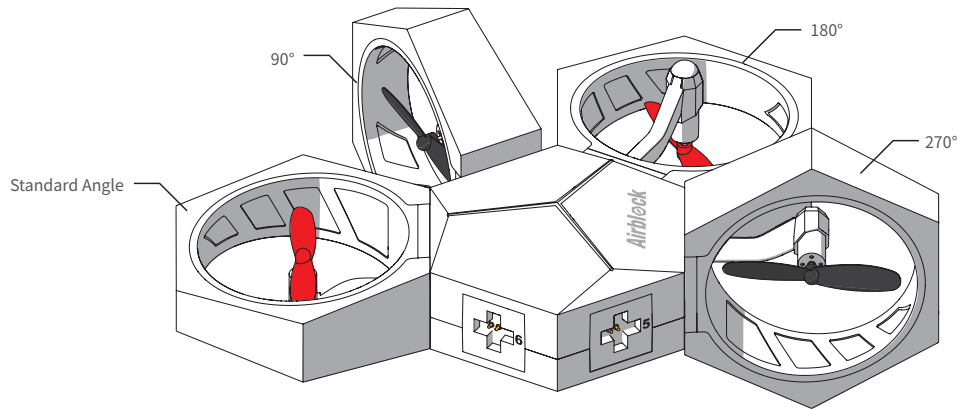

Power Module

Port Numbers

The power modules of red propellers are connected to Ports 1, 3, 5 respectively, with the front module to Port 1.

Connect the power modules of black propellers to Ports 2,4,6.

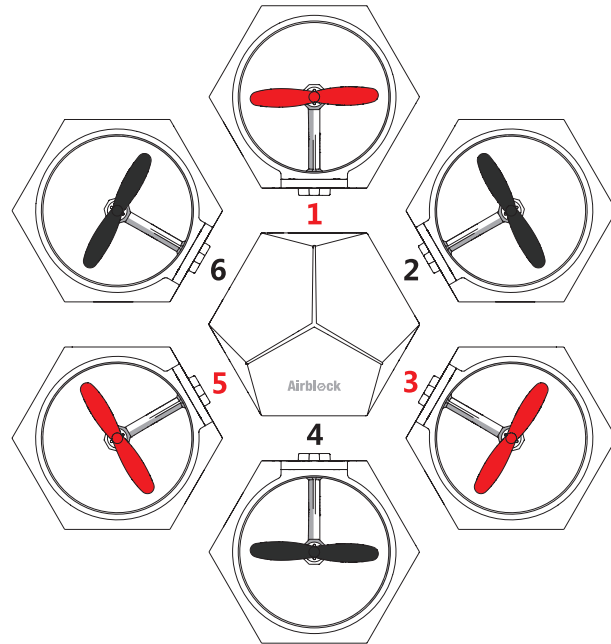

Stickers

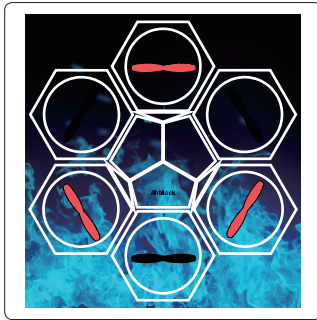

Fuselage Stickers

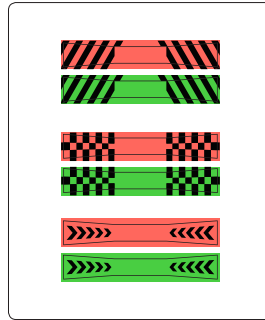

Power Module Stickers

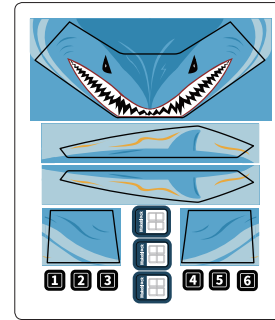

Hovercraft Stickers

Stickers

Power Module Stickers:

Attached to power module side in order to distinguish the direction of Airblock during flight. It is recommended to attach a red sticker to the aircraft front power module (Position 1) and a green sticker to the black propeller power module (Position 4). Other power modules do not need stickers.

There are 3 different styles of stickers -- you can choose according to your favor.

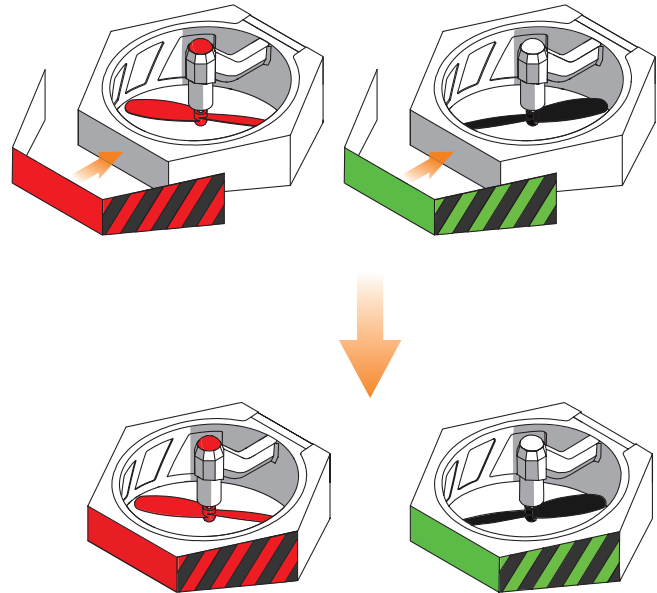
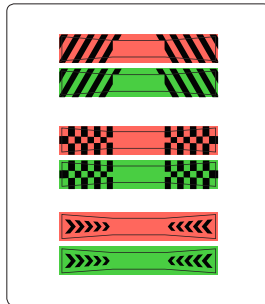

User Guide to Aircraft Mode

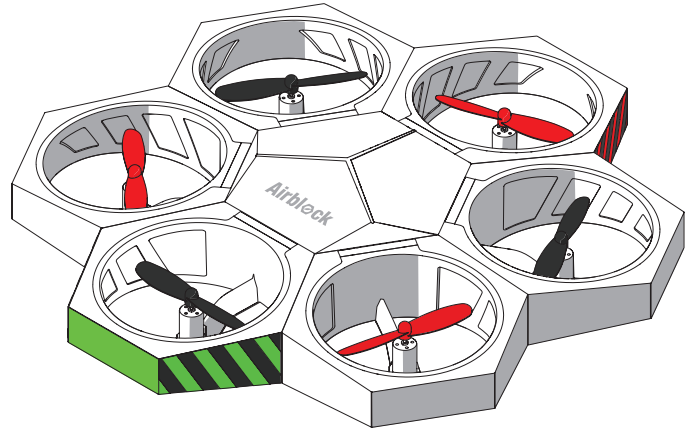

Operating Environment

Space larger than 3m×3m×3m is recommended for indoor flying.



Warning:

- Land: soft surfaces such as carpets and grass may cause interference to the ultrasonic sensor. It is recommended to take off from hard and flat surfaces.
- Water: do not start or fly the aircraft over water to prevent accidental falling into water, which can cause short circuit and fire damage to the machine.
- Outdoors: a windy environment may interfere the aircraft's normal flight.
- Before starting, make sure each module is assembled correctly and the protective cover is removed. The protective cover could affect the airflow and aircraft takeoff can be interfered. Place the aircraft on an open ground. Ensure no obstacles within a two-meter radius.
- Shutting down power on Makeblock App during flight can cause sudden drop to the aircraft. This may damage the equipment.
- Aerobatic flight needs a larger space in order to avoid collisions.
- High speed rotating motors and propellers may cause injury. Please keep a safety distance from the aircraft before operating Airblock.
- Dust, hair, fur, or water trapped in Airblock may result in motor malfunction or damage to electronic parts.

Installation Step 1

Installing the aircraft front power module

Install aircraft front power module with red foot pad onto Port 1 of the main control module.

 **Warning:**

If the front module is installed improperly, the direction of flight can not be controlled properly.

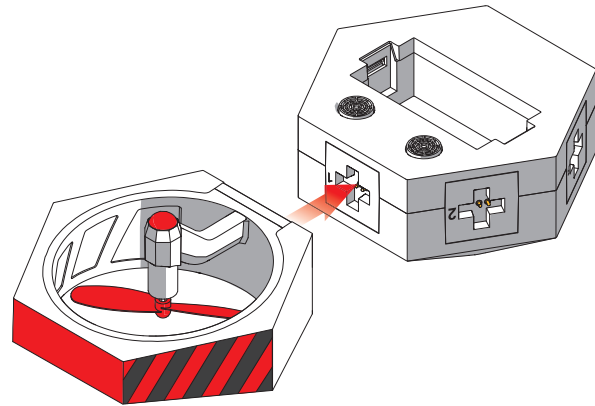

Installation Step 2

Install other power modules

Install the remaining power modules in sequence onto the main control module.

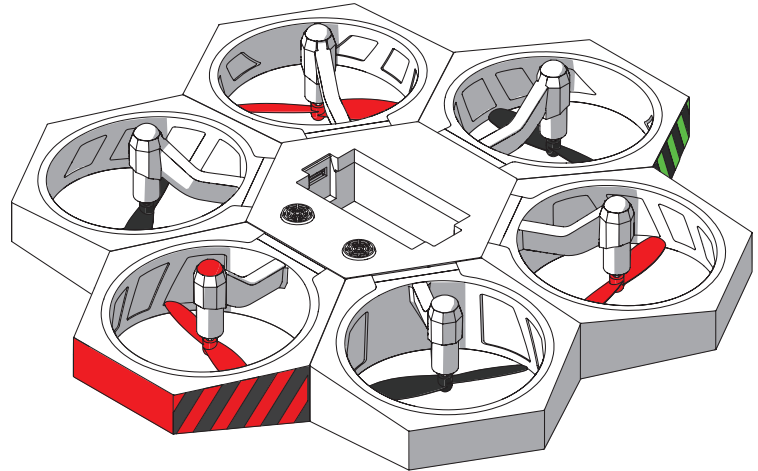

Installation Step 3

Battery Installation

After a fully charged battery is inserted, Airblock will be automatically turned on and enters the standby mode. The LED on the main control module top will display a white light. When Bluetooth is successfully connected, the light in front will turn red, and the light at rear will turn green.

Warning:

Before taking off, please ensure Airblock has its top facing upward and Airblock is placed on a flat ground. The picture on the right shows the situation when Airblock has its bottom facing upward.

In Aircraft mode, the protective cover must be removed.

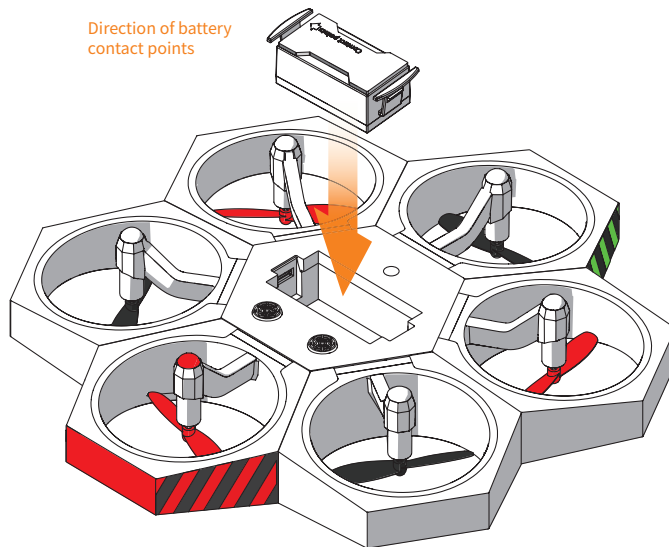

Control



Step 1

Follow the instructions on the first page of User Guide to download and install the application. Open the Makeblock application and move the tablet or smartphone close to the running Airblock, Bluetooth connection should be paired.



Step 2

Enter the control interface after successful connected. (Note: interface or icons may vary after software updates. Please follow the interface of the latest version. This instruction manual is for reference purpose only.) Follow the procedures on the New User Guide to familiarize with the functions of different keys and learn how to use the Airblock.

User Guide to Hovercraft Mode

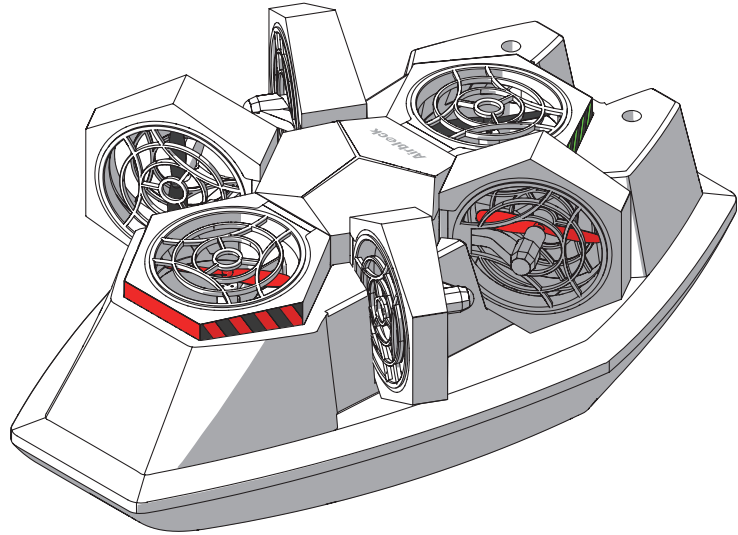

Operating Environment

Recommended to operate in open area.



Warning:

- Software: Choose Land or Water mode to control depending on the environment.
- Land: do not drive the hovercraft on muddy , rugged , or mesh surfaces.
- Water: do not drive the hovercraft on water with waves or obstacles. Do not use Hovercraft over wide water area, as the Bluetooth connection range is limited.
- High speed rotating motors and propellers may cause injury. Please keep a safety distance from the aircraft before operating Airblock.
- Dust, hair, fur, or water trapped in Airblock may result in motor malfunction or damage to electronic parts.
- Hovercraft must be installed correctly under user manual before operating on the water.

Installation Step 1

Battery Installation

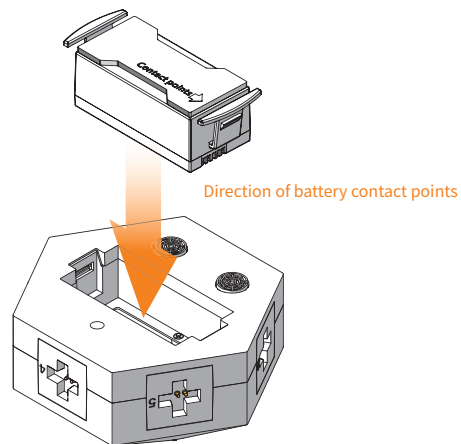

Installation Step 2

Install the protective cover

The protective covers must be installed in Hovercraft mode to protect the propellers and prevent the propellers from causing damage.

The protective covers of Port1 and 4 are required only on the top side of the power modules.

There are two types of protective covers; Pay attention to their difference during installation.

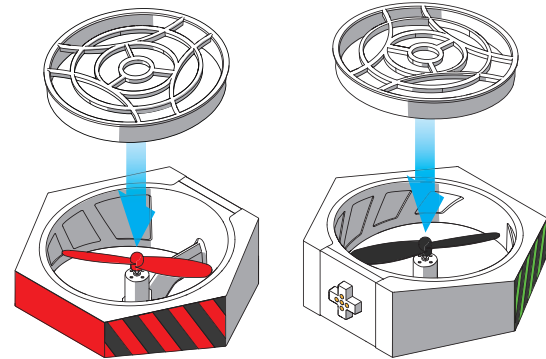
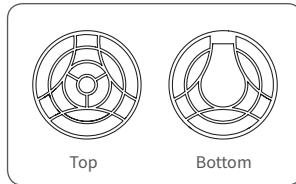

Installation Step 3

Connect the front power module and a black propeller power module to Port 1 and 4 on the main control module respectively.

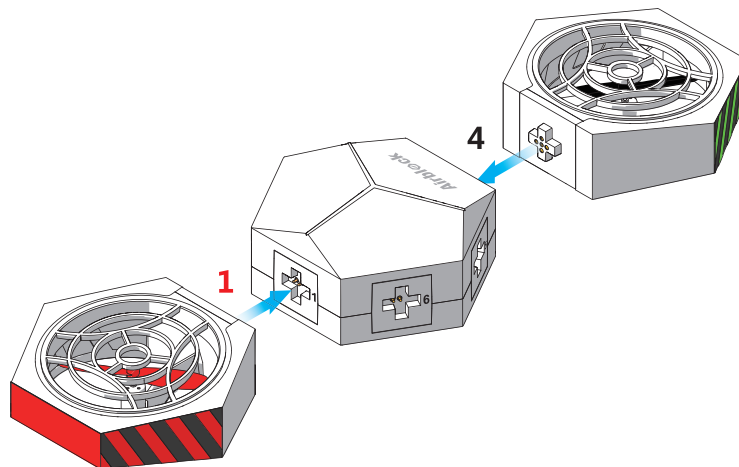

Installation Step 4

After connecting power modules to the main control module, fit the main control module onto the hovercraft hull.

 **Warning:**

Port 1 faces forwards (the smaller end of the hull is the bow)
The main control module must be installed in the correct direction, or it will not be able to control the direction of the hovercraft.

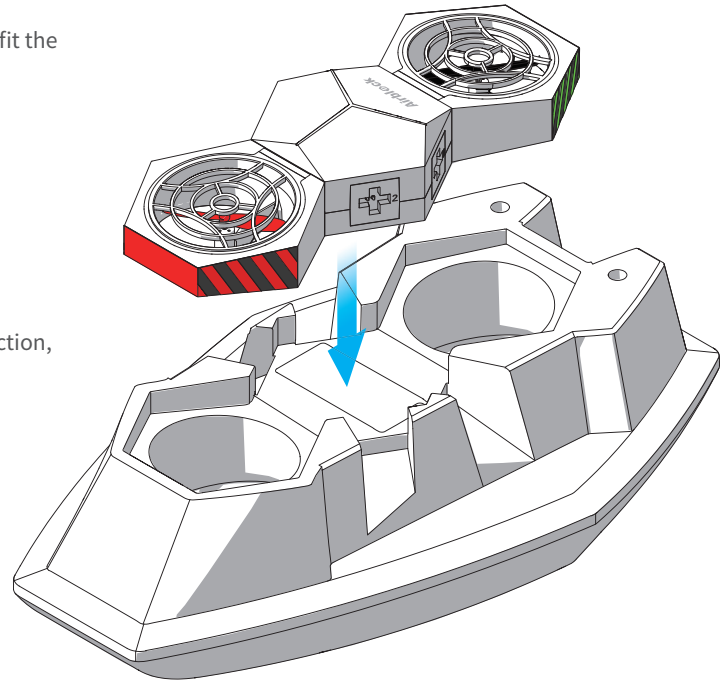

Installation Step 5

Protective covers are required on both top and bottom sides of other power modules.

There are two types of protective covers; Pay attention to their difference during installation.

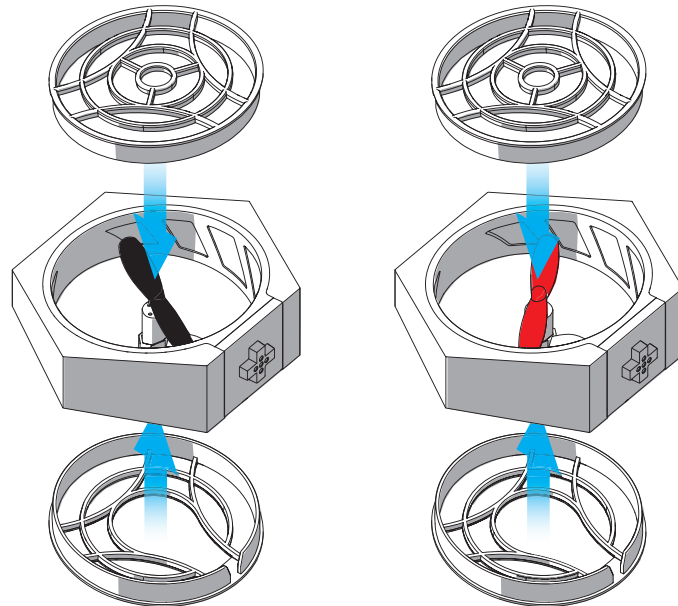
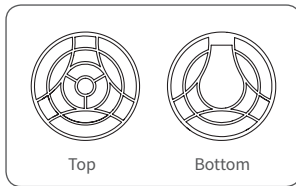

Installation Step 6

After fitting the protective covers, attach the 4 power modules onto the main control module according to directions indicated in the diagram below. Check if the protective covers are fitted in the accurate places and if the power modules are attached securely to the main control module.

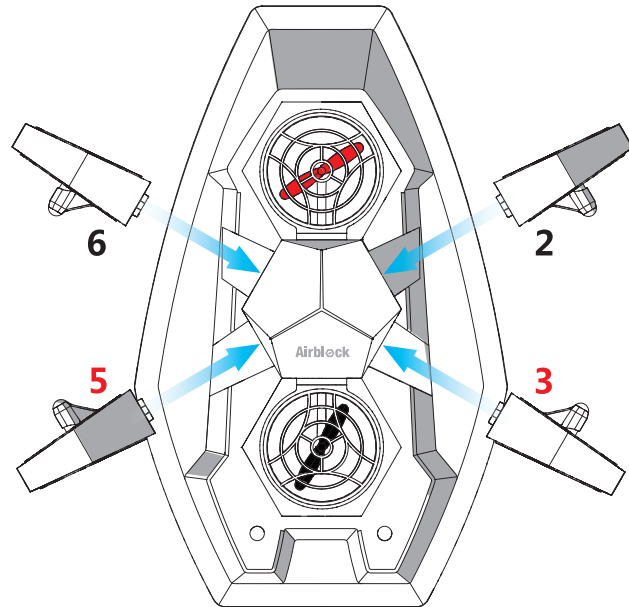

Control

Step 1

Follow the instructions on the first page of User Guide to download and install the application. Open the Makeblock application and move tablet or smartphone within close distance to running Airblock, Bluetooth connection should be paired.

Step 2

Enter the hovercraft control interface after successful connection. (Choose Land or Water Mode according to the corresponding environment. Incorrect mode selection may cause safety problems; please pay attention! Software interface or icons may vary after software updates. Please follow the directions of the latest version. This instruction manual is for reference purpose only.)

Follow procedures on the New User Guide to familiarize with the functions of the different keys and learn how to use Airblock.

User Guide to Custom Mode

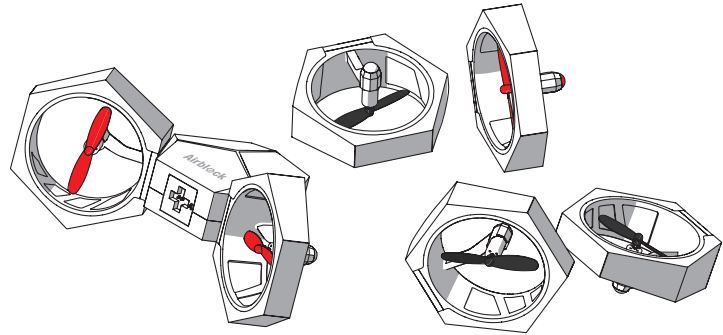

Operating Methods

Based on your own ideas, you can mount the power modules at different angles as either propellers or air-blowers. Programming different rotational velocities of motors can achieve corresponding airflow velocities and thrusts in different directions.

Operating Environment

Recommended for use on flat, clean floors or tables.



Warning:

- Land: soft surfaces such as carpets and grass may cause interference to the ultrasonic sensor. It is recommended to take off from hard and flat surfaces.
- Water: do not start or fly the aircraft over water to prevent accidental falling into water, which can cause short circuit and fire damage to the machine.
- In the air: Airblock is unable to fly normally in Custom Mode.
- Keep a distance of at least 2 meters from people or animals before running Airblock.
- High speed rotating motors and propellers may cause injury. Please keep a safety distance from the aircraft before operating Airblock.
- Dust, hair, fur, or water trapped in Airblock may result in motor malfunction or damage to electronic parts.

Programming

Examples for reference: <http://learn.makeblock.com>

Step 1

Follow the instructions on the first page of User Guide to download and install the application. Open the Makeblock application and move the tablet or smartphone close to the running Airblock, Bluetooth connection should be paired.

Step 2

Tap on the "New Project" option and select "Customize" to create a new controlling program for Airblock

Step 3

In "DESIGN" mode, drag and drop required keys modules into the edit area on the right. Tap on the module to enter the "Code" mode.

Step 4

In "Code" mode, drag the motor speed block to "When button pressed" and enter the corresponding number to set the motor speed.

At the same time, make sure the motor speed is "0" for "when button released"; otherwise the motor may continue uncontrolled, which can cause danger.

Examples for reference: <http://bbs.makeblock.com>

Troubleshooting

Propellers are not spinning

Poor connection

1. Check if the connection of the power module and the main control module is too widely-spaced, connection is uneven, or foreign matter is present.
 2. Check if the contact points of metal spring pins have been oxidized or have been damaged.
-

The motor shaft gets stuck.

Check if any foreign matter is tangled on the motor shaft; remove the foreign matter.

Bluetooth disconnected

Use application to reconnect to Bluetooth.

Application settings error

When programming the motor in Custom Mode, check if the motor runs when the application is launched, check whether the port numbers in the block are correct.

Direction is incorrect

Aircraft head module is installed in the wrong position

1. When in Aircraft mode, if you have problems in controlling the direction, check if the aircraft front power module with red LED is in the right position, and follow the installation steps in User Guide to re-install.
2. When in Hovercraft mode, check if the main control module is installed in the correct direction, and follow the installation steps in User Guide to re-install.

Power supply LED does not light up

Battery has no power

Try again after charging battery for half an hour or longer.

Incorrect battery installation

Battery is installed in the incorrect position. Re-install the battery correctly and confirm that battery is installed properly.

Static electricity causing abnormality

Static electricity may cause an abnormal shutdown. Remove the battery to reinstall.

Fail to take off

Power supply is insufficient

After successful connection to the application, you may check the power supply level in the control interface. If power supply is less than 20%, please charge the battery.

Protective cover is not removed

Protective cover must be removed for Aircraft mode. Protective cover is only applicable for using Hovercraft mode.

Power module is installed in the wrong direction

Check all power modules; the foot pad side must be facing downwards.

Firmware upgrade

To optimize user experience, Makeblock will continue to upgrade the software. After connecting to the Bluetooth device, you can click the setting icon on the upper left corner of the application. Select firmware information to view the current firmware version of the device. If there is an upgrade released, you may click and upgrade your device. If the upgrade fails, you may try again after connecting the Bluetooth.

Any Changes or modifications not expressly approved by the party responsible for compliance could void the user's authority to operate the equipment.

FCC Statement

Note: This equipment has been tested and found to comply with the limits for a Class B digital device, pursuant to part 15 of the FCC Rules. These limits are designed to provide reasonable protection against harmful interference in a residential installation. This equipment generates uses and can radiate radio frequency energy and, if not installed and used in accordance with the instructions, may cause harmful interference to radio communications. However, there is no guarantee that interference will not occur in a particular installation. If this equipment does cause harmful interference to radio or television reception, which can be determined by turning the equipment off and on, the user is encouraged to try to correct the interference by one or more of the following measures:

- Reorient or relocate the receiving antenna.
- Increase the separation between the equipment and receiver.
- Connect the equipment into an outlet on a circuit different from that to which the receiver is connected.
- Consult the dealer or an experienced radio/TV technician for help.

RF warning statement

The device has been evaluated to meet general RF exposure requirement. The device can be used in portable exposure condition without restriction.

DECLARATION OF CONFORMITY

Declaration of conformity Hereby, Makeblock Co., Ltd., declares that this product is in compliance with the essential requirements and other relevant provisions of Directive RED 2014/53/EU and the RoHS directive 2011/65/EU

WARNING:

CHOKING HAZARD- Small parts. Not for children under 3 years.
To be used by children only when under adult supervision.

