

HM160 Instruction Manual

Global Exclusive Patent Technology

The P.C.T. number:087461

RF Radiation Information

RF Radiation Profile

Your radio is designed and tested to comply with a number of national and international standards and guidelines (listed below) regarding human exposure to radio frequency electromagnetic energy. This radio complies with the IEEE and ICNIRP exposure limits for occupational/controlled RF exposure environment at operating duty factors of up to 50% transmitting and is authorized by the FCC for occupational use only. In terms of measuring RF energy for compliance with the FCC exposure guidelines, your radio radiates measurable RF energy only while it is transmitting (during talking in PTT mode), not when it is receiving (listening) or in standby mode.

The device complies with SAR and/or RF field strength limits of RSS-102 requirement

RF Radiation Safety

In order to ensure user health, experts from relevant industries including science, engineering, medicine and health work with international organizations to develop standards for safe exposure to RF radiation. These standards consist of:

- United States Federal Communications Commission, Code of Federal Regulations; 47CFR part 2 sub-part J;
- American National Standards Institute (ANSI)/Institute of Electrical and Electronic Engineers (IEEE) C95. 1-1992;
- Institute of Electrical and Electronic Engineers (IEEE) C95. 1 – 1999;
- International Commission on Non-Ionizing Radiation Protection (ICNIRP) 1998;

FCC Regulations

Federal Communication Commission (FCC) requires that all radio communication products should meet the requirements set forth in the above standards before they can be marketed in the U.S, and the manufacturer shall post a RF label on the product to inform users of operational instructions, so as to enhance their occupational health against exposure to RF energy.

Part 15 Compliance

This equipment has been tested and found to comply with the limits for a Class B digital device, pursuant to part 15 of the FCC Rules. These limits are designed to provide reasonable protection against harmful interference in a residential installation. This equipment generates uses and can radiate radio frequency energy and, if not installed and used in accordance with the instructions, may cause harmful interference to radio communications. However, there is no guarantee that interference will not occur in a particular installation. If this equipment does cause harmful interference to radio or television reception, which can be determined by turning the equipment off and on, the user is encouraged to try to correct the interference by one or more of the following measures:

- Reorient or relocate the receiving antenna.
- Increase the separation between the equipment and receiver.
- Connect the equipment into an outlet on a circuit different from that to which the receiver is connected.
- Consult the dealer or an experienced radio/TV technician for help. Note: “Changes or modifications to this unit not expressly approved by the party responsible for compliance could void the user’ s authority to operate the equipment.”

EU Regulatory Conformance

As certified by the qualified laboratory, the product is in compliance with the essential requirements and other relevant provisions of the Directive 1999/5/EC. Please note that the above information is applicable to EU countries only.

CE 0678 !

Waterproof Design Warning:

This product is the IP67 waterproof design, in order to achieve the best performance, before the end-user use it, and please pay the highest attention for the following three points:

1, To tightening the antenna because there is an O-ring at the bottom of antenna side

2, To rotate tightly the round socket cap because there is an O-ring design around the cap

3, Non-professionals can not disassemble the machine.

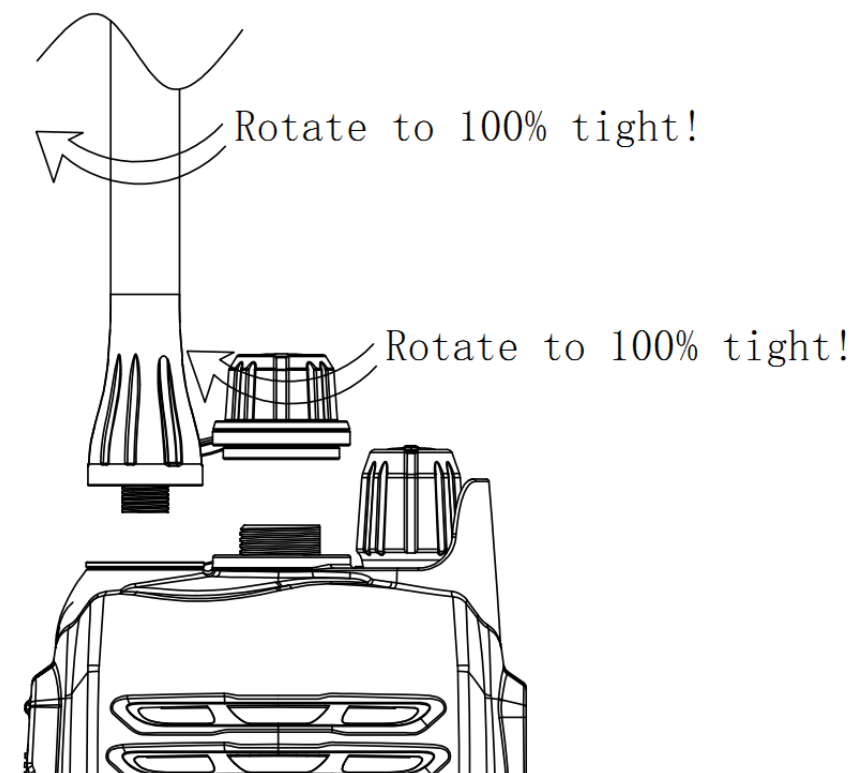

TABLE OF CONTENT

A. KEY FUNCTION (HM160)	5
A.1 KEY ARRANGEMENT (HM160)	5
A.2 HM160 LCD	5
B. DIRECT KEY OPERATION	6
B.1 POWER ON/OFF (HARDWARE)	6
B.2 VOLUME CONTROL (HARDWARE)	6
B.3 SQUELCH	6
B.4 UP/DOWN	6
B.5 16/9 CHANNEL	6
B.6 Hi/Lo Tx POWER	7
B.7 Wx	7
B.8 BAND	8
B.9 SCAN	8
B.10 MEM	8
B.11 WATCH	9
B.12 BACKLIGHT	9
B.13 KEY LOCK	10
C. SPECIAL FUNCTION OPERATION	10
C.1 TX TIME OUT	10
C.2 POWER SAVE MODE	10
C.3 DISTINCT TONE	FEHLER! TEXTMARKE NICHT DEFINIERT.
C.4 TX INDICATOR	10
D. EUROPEAN KEY OPERATION	10
D1. PROGRAMMING ATIS ID	10
D2 SPECIAL FUNCTION KEYS	12
APPENDIX A – NEAR LIGHTNING STRIKE TEST	12
APPENDIX B – CHANNEL LIST	13

A. KEY FUNCTION (HM160)

Key	Short Press (< 3 sec)	Long Press (> 3 sec)
HI/Lo /Lock	TX Power Hi/Low	Key Lock
16/9	CH 16	CH09
DW/TriW	Dual Watch mode	Tri Watch mode
WX/ALT	Weather Channel	Alert enable/disable
SCAN	All Scan/all memory Scan	Priority all/memory Scan
MEM	MEMORY Mode	Save/Delete Memory Channel
Up/Down	Channel/ Setting Up/Down	Channel Fast up/Fast down
CH*/UIC	Private channel	UIC Band
Sql	Sql Set	

Rotary Key

Volume	Power ON / OFF and Adjust the volume level
--------	--

A.1 Key arrangement (HM160)

PTT	CH/WX/UIC	UP	UIC
SQL	16/9	DOWN	HI/LO/LOCK
	SCAN	MEM	DW/TRIW

A.2 HM160 LCD

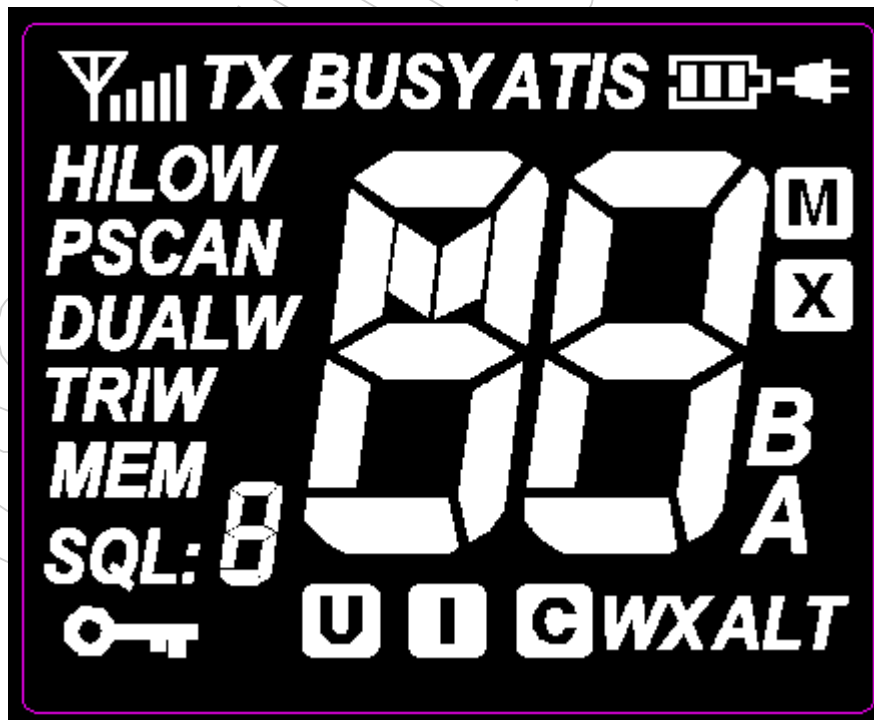

B. DIRECT KEY OPERATION

B.1 Power ON/OFF (Hardware)

Turn the Volume key knob clockwise until a click sound heard the unit will power on.
[The volume VR include the power switch]

The unit will start with Normal mode.

- Turn on the 1000Hz tone for 100ms
- Turn on the backlit in full scale for 5 sec
- Recall the last channel number, TX power settings and operational mode
- If no last channel info, go to Channel 16, TX Power be Hi

B.2 Volume Control (Hardware)

Adjust the volume knob to control the loudspeaker volume level.

B.3 Squelch

At the radio mode to adjust the squelch level, short press the SQL key will Flash SQL's level , press UP/DOWN key to select SQL level accordingly.

B.4 UP/DOWN

At the normal mode, they act as Channel Up/Down. When it press > 0.5 sec, the unit will start scrolls through the channels at 125ms intervals. It returns to normal mode when key press is released.

B.5 16/9 CHANNEL

Summary of CH16/9 Key operation:

1. Jump to either Channel 16 or 9 (priority channel) directly by pressing the 16 / 9 Key (short press to jump to priority CH16 at High Power and long press to jump to priority CH9 at High Power) if the current channel is not the priority channel.

Note: Accessing the priority channel will change the power setting to high power. The user can change the power setting to low power by pressing Hi/Lo/LOCK key. If the priority channel is limited by the cloning software for 1-W only, accessing priority channel will still follow the low power limitation. The setting in the cloning software takes precedent. It is done to make it consistent with the Fix VHF radio.

2. After the channel is tuned to the priority channel, the "P" icon is lit to indicate that the priority CH16 or CH9 has been reached. UP and Down key functions normally.

3. When the radio already tunes to the priority channel pressing 16/9 key will revert radio to the previously used working channel depending on how it being press (see flow chart above).

To reprogram a secondary priority channel:

1. Tune to priority CH9. It is indicated by “P” icon. It is done by pressing “16/9” key for more than 3 saccs.
2. Then, press and hold the “16/9”key for 3 seconds.
3. and the current secondary priority channel number should start flashing.
4. While the channel number is flashing, it can be changed with the “UP” and “DOWN” arrow buttons. The selection can be saved by pressing the “16/9” key (short) and the screen display “P” icon to indicate that the secondary priority channel has been changed.
5. The user can reprogram the secondary priority channel on the HM160

B.6 Hi/Lo Tx Power

Short press the HI/LO/LOCK key will toggle the TX power from Hi to Lo or vice versa. The corresponding HI or Lo icon will turn on the LCD.

Some of the channel has been limited to be low power only or high power only. Thus, the software needs to check against the channel setting stored in the EEPROM.

If the operation request is denied, error beeps tone will out

For some channel is allowed to over-rule the restriction temporary such as CH 13 & 67 in USA band. Press and hold the PTT key and hold the HI/LO/LOCK key to switch the TX power to Hi power

B.7 Wx

Short press WX/ALT key will enter Wx mode. Press Up/Down key to change Wx channel.

Weather Alert Operation:

1. Weather Alert is toggled (switch ON and OFF) by pressing and holding WX button in the weather mode. In the Weather Mode, toggling the Weather Alert function ON and OFF will toggle the icon “Alert” accordingly.
2. When Weather Alert function is enabled. Every 4 seconds the last used weather channel should be checked for weather alert tone when the radio is tuned to working channel. With Weather Alert Function enable, if the alert tone is detected, the “WX” and “Alert” symbol should flash and a short alarm tone should sound. The radio would automatically tune to the current monitor WX channel where the weather alert has been detected. The alert should be detected in all the modes of operation (Standby, Dual and Tri-watch, Scan etc.)

B.8 Private Channel

Short press CH/* /UIC key will enter Private channel. short Press Up/Down key to change private channel. The screen will display "--" if no private channel save in the eeprom

B.9 Scan

This is the function to scan for broadcasting channels. When available channel detected, the receiver will stop at that channel and continue to search when that transmission ceased.

There are 4 Scan modes available – All SCAN, Memory Scan, Priority Scan & Priority memory Scan, Default is All Scan

1. Short press the SCAN key to activate the SCAN function.
2. When the radio in the normal mode, All Scan will be initiated. When the radio in the All Scan mode, all channel will be scan in sequence.
3. When the radio in the memory mode, Memory Scan will be initiated. When either All Scan or Memory Scan is active, long press the Scan key will initiate Priority Scan.
4. Long press SCAN key during Scan operation will toggle All Scan or Memory Scan with Priority Scan. The "P" icon (priority icon) would be lit accordingly.

The memory channel will be stated whenever signal received. Once the transmission finished, the SCAN will automatically carry on to searching for next channel.

All Memory Scan

M1 – M2 – M3 - ... M10 – M1 - ...

All Scan

CH1-CH2-CH3-.....-CH88-CH1

Priority Memory Scan

M1 – CH 16 – M2 – CH 16 - ... CH 16 – M1 – M16 - ...

(M1; M2; M3 means 1st, 2nd, 3rd programmed channel)

Priority All Scan

CH1-CH16-CH2-CH16-CH3-CH16-.....CH88-CH16-L1-CH16-...

(The radio only has L1 as its private channel)

B.10 MEM

Press the MEM to enter the memory mode when there is at least one channel in the memory. The channel sequences will follow the programmed channels in the memory. The "MEM" icon will be turned on. Short press the SCAN will start MEMORY SCAN.

Adding/Deleting CH from the memory:

1. During the normal mode, use the UP/DOWN key to select the desired channel for programming.
2. Long press the MEM key to store up the channel as memory channel.
3. The “M” icon shows up to indicate the current channel has been saved in the memory. No limited of memory channels.
4. Separate memory channel exists for USA, International, and Canadian Frequency group.
5. During the normal mode, use the UP/DOWN key to select the channel to be deleted.
6. Long press the MEM key to delete the channel from the memory.

B.11 Watch

Dual Watch

Short press DW/TriW key to activate the DUAL WATCH mode. Monitor the current channel and Ch 16 in cycle.

Whenever, Weather Alert is activated, the Wx Alert channel will be monitored once every 4sec.

Current Channel - CH 16 – Current Channel – CH 16 – Wx Alert - Current Channel -...

Tri Watch

Long press DW/TRI key to activate the TRI WATCH mode. Monitor the Ch 16, current channel and the 2nd Priority CH in cycle.

Note: programmed channel is the secondary priority Channel. Default secondary priority channel is CH9.

Current Channel – CH 16 – 2nd Priority CH – Current Channel – CH 16 – 2nd Priority CH – Current Channel - ...

Note: When weather Alert is enabled, similar scheduling as the Dual-watch is used.

B.12 Backlight

Any key press will turn on the backlit (if backlit setting is ON) except the PTT key. The backlit should be remaining on for 5 sec if no any keys pressed. The time out will be reset if any key pressed within the time frame.

B.13 Key Lock

Long press for 4 sec the Hi/Lo/Lock key will lock the keypad except the PTT key and backlight function. A key lock icon will be displayed. Long press the Hi/Lo/Lock key again will release the key lock function.

C. SPECIAL FUNCTION OPERATION

C.1 TX Time Out

The transmission will be automatically turn off after PTT key pressed over 5 consecutive minutes. The Tx mode will be terminate and back to Rx mode. Once the PTT key is released, the TX time out timer will be reset. PTT key will work back normally.

C.2 Power save Mode

Normal Mode
100ms ON, 300ms OFF

C.3 TX Indicator

When the radio is transmitting, the "TX" icon will be lit up.

D. EUROPEAN KEY OPERATION

Most of the functions in the radio are the same as the US model. These are the functions that work differently.

D1. Programming ATIS ID

ATIS function only exists in European Model. Therefore, it only functions when the European radio is tuned to the International Frequency Group. After ATIS ID is being program into the radio via the keypad or the cloning software, the ATIS function will be enabled all the time. The user cannot disable it.

To enable the customer to enter ATID ID into the radio from the keypad, the check box next to the ATIS entry by user on the Cloning software has to be ticked.

Programming ATIS ID from the Keypad

1. Programming start with the radio turn OFF.
2. Long press Hi/Lo/Lock and turn radio ON to access the ATIS mode.
3. The front digit will indicate the digit position of the ATIS ID. The rear digit will blink continuously. The rear digit indicates the ATIS ID. Changing the value of the rear digit can be achieved using the "UP/DOWN" Key.
4. Press "MEM" key to confirm the selection and move to the next digit.
5. After the user complete the 9 digit ATIS ID, the user has to enter the ATIS ID the second time to avoid invalid entry. If different ATIS ID is entered, operation will be canceled The user has to repeat step one to initiate the ATID ID entering sequence.

6. After entering a valid ATID ID for the second time, the ATIS ID will be flashed in sequence one time on the screen, and the radio will revert into previously working channel saved in the memory before the radio is turn off. If no channel is found in the memory, the radio will revert to CH16 at High Power setting

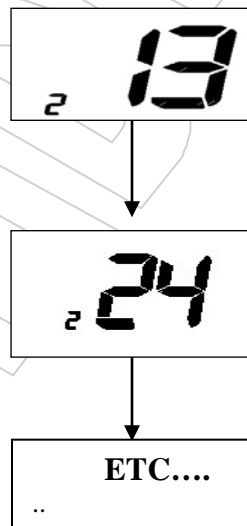

7. Store the ATIS ID permanently into the radio by turning the radio off.
8. After the ATIS ID being programmed into the radio, from OFF position holding HI/LO/Lock and turning the radio ON will make the radio flash its ATIS ID. After this stage, only with the cloning software the ATIS ID be modified or erased.

D2 Special function keys

If you press the AX/ALT key and power key then you can enter the upgrade mode directly

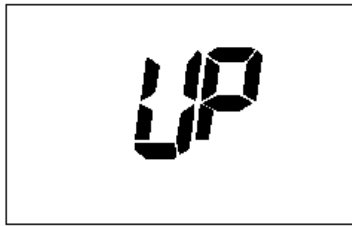

Press the DW/TRW key and the power key , then you can enter the writing channel mode directly

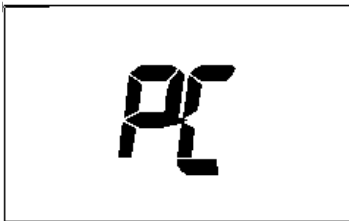

Appendix A – Near Lightning Strike Test

This appendix describes the general procedure for evaluating the immunity to near lightning strikes (NLS) of the HM160 VHF Radio.

The test simulates a slow, high-energy pulse produced by an NLS event.

Related External Documents

- **BS EN 61000-4-5 : 2006**
- **EMC Directive 2004/108/EC**

List of Abbreviations

AE	Auxiliary Equipment
CE	Conducted Emissions
EMC	Electromagnetic Compatibility
EN	European Norm
EUT	Equipment Under Test
FTB	Fast Transient Burst
MED	Marine Equipment Directive
QP	Quasi Peak

Safety

The high voltage interference pulse can contain a very large quantity of energy and every precaution shall be taken to avoid contact with EUT during a test. It is highly recommended that at least one other person is present (or very close by) during the test.

Test Configuration

EUT Setup

The EUT shall be setup in a typical system configuration on an isolated wooden bench with NO GROUNDPLANE. The power to the EUT and auxiliary equipment shall be from 12V or 24V sealed lead-acid batteries via a suitable fuse. The length of the EUT power cable shall be no more than 2m. Any screens within the system shall be terminated at the battery –vet connection.

EUT Operating Configuration

All operating configurations should be tested with appropriate performance criteria defined for each test.

Performance Criteria

From BS EN 61000-4-5 : 2006

Performance criteria C: Temporary loss of function or degradation of performance, the correction of which requires operator intervention.

Appendix B – Channel List

International Marine VHF Channels and Frequencies

CH No.	XMIT Freq	RCV Freq	Single	Freq Use
01	156.050	160.650		Public Correspondence, Port Operations and Ship Movement
02	156.100	160.700		Public Correspondence, Port Operations and Ship Movement
03	156.150	160.750		Public Correspondence, Port Operations and Ship Movement
04	156.200	160.800		Public Correspondence, Port Operations and Ship Movement
05	156.250	160.850		Public Correspondence, Port Operations and Ship Movement
06	156.300	156.300	x	Intership 1
07	156.350	160.950		Public Correspondence, Port Operations and Ship Movement
08	156.400	156.400	x	Intership
09	156.450	156.450	x	Intership, Port Operations and Ship Movement
10	156.500	156.500	x	Intership, Port Operations and Ship Movement 2
11	156.550	156.550	x	Port Operations and Ship Movement
12	156.600	156.600	x	Port Operations and Ship Movement
13	156.650	156.650	x	Intership Safety, Port Operations and Ship Movement 3
14	156.700	156.700	x	Port Operations and Ship Movement
15	156.750	156.750	x	Intership and On-board Communications at 1W only 4
16	156.800	156.800	x	Distress, Safety and Calling
17	156.850	156.850	x	Intership and On-board Communications at 1W only 4
18	156.900	161.500		Public Correspondence, Port Operations and Ship Movement
19	156.950	161.550		Public Correspondence, Port Operations and Ship Movement
20	157.000	161.600		Public Correspondence, Port Operations and Ship Movement
21	157.050	161.650		Public Correspondence, Port Operations and Ship Movement
22	157.100	161.700		Public Correspondence, Port Operations and Ship Movement
23	157.150	161.750		Public Correspondence, Port Operations and Ship Movement
24	157.200	161.800		Public Correspondence, Port Operations and Ship Movement
25	157.250	161.850		Public Correspondence, Port Operations and Ship Movement
26	157.300	161.900		Public Correspondence, Port Operations and Ship Movement
27	157.350	161.950		Public Correspondence, Port Operations and Ship Movement
28	157.400	162.000		Public Correspondence, Port Operations and Ship Movement
60	156.025	160.625		Public Correspondence, Port Operations and Ship Movement
61	156.075	160.675		Public Correspondence, Port Operations and Ship Movement
62	156.125	160.725		Public Correspondence, Port Operations and Ship Movement
63	156.175	160.775		Public Correspondence, Port Operations and Ship Movement
64	156.225	160.825		Public Correspondence, Port Operations and Ship Movement
65	156.275	160.875		Public Correspondence, Port Operations and Ship Movement
66	156.325	160.925		Public Correspondence, Port Operations and Ship Movement
67	156.375	156.375	x	Intership, Port Operations and Ship Movement 2
68	156.425	156.425	x	Port Operations and Ship Movement
69	156.475	156.475	x	Intership, Port Operations and Ship Movement
71	156.575	156.575	x	Port Operations and Ship Movement

72	156.625	156.625	x	Intership
73	156.675	156.675	x	Intership 2
74	156.725	156.725	x	Port operations and Ship movement
75	156.775	156.775	x	See Note 5
76	156.825	156.825	x	See Note 5
77	156.875	156.875	x	Intership
78	156.925	161.525		Public correspondence, Port Operations and Ship Movement
79	156.975	161.575		Public correspondence, Port Operations and Ship Movement
80	157.025	161.625		Public correspondence, Port Operations and Ship Movement
81	157.075	161.675		Public correspondence, Port Operations and Ship Movement
82	157.125	161.725		Public correspondence, Port Operations and Ship Movement
83	157.175	161.775		Public correspondence, Port Operations and Ship Movement
84	157.225	161.825		Public correspondence, Port Operations and Ship Movement
85	157.275	161.875		Public correspondence, Port Operations and Ship Movement
86	157.325	161.925		Public correspondence, Port Operations and Ship Movement
87	157.375	157.375	x	Port Operations and Ship Movement
88	157.425	157.425	x	Port Operations and Ship Movement

- Intership channels are for communications between ship stations. Intership communications should be restricted to Channels 6, 8, 72 and 77. If these are not available, the other channels marked for Intership may be used.
- Channel 70 is used exclusively for Digital Selective Calling (DSC) and is not available for regular voice communications.

Notes:

1. Channel 06 may also be used for communications between ship stations and aircraft engaged in coordinated search and rescue operations. Ship stations should avoid harmful interference to such communications on channel 06 as well as to communications between aircraft stations, ice breakers and assisted ships during ice seasons.
2. Within the European Maritime Area and in Canada, channels 10, 67 and 73 may also be used by the individual administrations concerned for communication between ship stations, aircraft stations and participating land stations engaged in coordinated search and rescue and anti-pollution operations in local areas. Channels 10 or 73 (depending on location) are also used for the broadcast of Marine Safety Information by the Maritime and Coast Guard Agency in the UK only.
3. Channel 13 is designated for use on a worldwide basis as a navigation safety communication channel, primarily for intership navigation safety communications.
4. Channels 15 and 17 may also be used for on-board communications provided the effective radiated power does not exceed 1 Watt.
5. The use of Channels 75 and 76 should be restricted to navigation related communication only and all precautions should be taken to avoid harmful interference to channel 16. Transmit power is limited to 1 Watt.

U.S. Marine VHF Channels and Frequencies

CH. No	XMIT Freq	RCV Freq	Single	Freq Use
01A	156.050	156.050	x	Port Operations and Commercial, VTS. Available only in New Orleans / Lower Mississippi area. 1
03A	156.150	156.150	x	U.S. Government only
05A	156.250	156.250	x	Port Operations or VTS in the Houston, New Orleans and Seattle areas.
06	156.300	156.300	x	Intership Safety
07A	156.350	156.350	x	Commercial
08	156.400	156.400	x	Commercial (Intership only)
09	156.450	156.450	x	Boater Calling. Commercial and Non-Commercial.
10	156.500	156.500	x	Commercial
11	156.550	156.550	x	Commercial. VTS in selected areas.
12	156.600	156.600	x	Port Operations. VTS in selected areas.
13	156.650	156.650	x	Intership Navigation Safety (Bridge-to-bridge). Ships >20meters in length maintain a listening watch on this channel in US waters. 2, 6
14	156.700	156.700	x	Port Operations. VTS in selected areas.
15	-	156.750	x	Environmental (Receive only). Used by Class 'C' EPIRBs. 3
16	156.800	156.800	x	International Distress, Safety and Calling. Ships required to

Channel	Frequency (MHz)	Frequency (MHz)	Usage
			carry radio, USCG, and most coast stations maintain a listenin watch on this channel. 4
17	156.850	156.850	x State Control 5
18A	156.900	156.900	x Commercial
19A	156.950	156.950	x Commercial
20	157.000	161.600	Port Operations (duplex)
20A	157.000	157.000	x Port Operations
21A	157.050	157.050	x U.S. Coast Guard only
22A	157.100	157.100	x Coast Guard Liaison and Maritime Safety Information Broadcasts. Broadcasts announced on channel 16.
23A	157.150	157.150	x U.S. Coast Guard only
24	157.200	161.800	Public Correspondence (Marine Operator)
25	157.250	161.850	Public Correspondence (Marine Operator)
26	157.300	161.900	Public Correspondence (Marine Operator)
27	157.350	161.950	Public Correspondence (Marine Operator)
28	157.400	162.000	Public Correspondence (Marine Operator)
61A	156.075	156.075	x U.S. Government only
63A	156.175	156.175	x Port Operations and Commercial, VTS. Available only in New Orleans / Lower Mississippi area.
64A	156.225	156.225	x U.S. Coast Guard only
65A	156.275	156.275	x Port Operations
66A	156.325	156.325	x Port Operations
67	156.375	156.375	x Commercial. Used for Bridge-to-bridge communications in lower Mississippi River. Intership only. 6
68	156.425	156.425	x Non-Commercial
69	156.475	156.475	x Non-Commercial
71	156.575	156.575	x Non-Commercial
72	156.625	156.625	x Non-Commercial (Intership only)
73	156.675	156.675	x Port Operations
74	156.725	156.725	x Port Operations
77	156.875	156.875	x Port Operations (Intership only) 5
78A	156.925	156.925	x Non-Commercial
79A	156.975	156.975	x Commercial. Non-Commercial in Great Lakes only.
80A	157.025	157.025	x Commercial. Non-Commercial in Great Lakes only
81A	157.075	157.075	x U.S. Government only – Environmental protection operations.
82A	157.125	157.125	x U.S. Government only
83A	157.175	157.175	x U.S. Coast Guard only
84	157.225	161.825	Public Correspondence (Marine Operator)
85	157.275	161.875	Public Correspondence (Marine Operator)
86	157.325	161.925	Public Correspondence (Marine Operator)
87	157.375	161.975	Public Correspondence Marine Operator)
88	157.425	162.025	Public Correspondence only near Canadian border
88A	157.425	157.425	x Commercial, Intership only

- Recreational boaters normally use channels listed as Non-Commercial: 68, 69, 71, 72, 78A.
- Channel 70 is used exclusively for Digital Selective Calling (DSC) and is not available for regular voice communications.
- Channels 75 and 76 are reserved as guard bands for Channel 16 and are not available for regular voice communications.

Notes:

1. The letter "A" following a channel number indicates simplex use of the ship station transmit side of an international semi-duplex channel. Operations are different from that of international operations on that channel.
2. Channel 13 should be used to contact a ship when there is danger of collision. All ships of length 20 meters or greater are required to guard VHF channel 13, in addition to VHF channel 16, when operating within U.S. territorial waters.
3. Channel is Receive Only.
4. Channel 16 is used for calling other stations or for distress alerting.
5. Output power is fixed at 1 watt only.
6. Output power is initially set to 1 watt. User can temporarily override this restriction to transmit at high power.

Canadian Marine VHF Channels and Frequencies

CH No.	XMIT Freq	RCV Freq	Area of Operation Use
01	156.050	160.650	PC Public Correspondence
02	156.100	160.700	PC Public Correspondence
03	156.150	160.750	PC Public Correspondence
04A	156.200	156.200	PC Intership, Ship/Shore and Safety: Canadian Coast Guard S&R
04A	156.200	156.200	EC Intership, Ship/Shore and Commercial: Commercial fishing only
05A	156.250	156.250	Ship Movement
06	156.300	156.300	All areas Intership, Commercial, Non-commercial and Safety: May be used for search and rescue communications between ships and aircraft.
07A	156.350	156.350	All areas Intership, Ship/Shore, Commercial
08	156.400	156.400	WC, EC Intership, Commercial and Safety: Also assigned for operations in the Lake Winnipeg area.
09	156.450	156.450	AC Intership, Ship/Shore, Commercial, Non-commercial and Ship Movement: May be used to communicate with aircraft and helicopters in predominantly maritime support operations.
10	156.500	156.500	AC, GL Intership, Ship/Shore, Commercial, Non-commercial, Safety and Ship Movement: May also be used for communications with aircraft engaged in coordinated search and rescue and antipollution operations.
11	156.550	156.550	PC, AC, GL Intership, Ship/Shore, Commercial, Non-commercial and Ship Movement: Also used for pilotage purposes.
12	156.600	156.600	WC, AC, GL Intership, Ship/Shore, Commercial, Non-commercial and Ship Movement: Port operations and pilot information and messages.
13	156.650	156.650	All areas Intership, Commercial, Non-commercial and Ship Movement: Exclusively for bridge-to-bridge navigational traffic. Limited to 1-watt maximum power.
14	156.700	156.700	AC, GL Intership, Ship/Shore, Commercial, Non-commercial and Ship Movement: Port operations and pilot information and messages.
15	156.750	156.750	All areas Intership, Ship/Shore, Commercial, Non-commercial and Ship Movement: All operations limited to 1-watt maximum power. May also be used for on-board communications.
16	156.800	156.800	All areas International Distress, Safety and Calling ²
17	156.850	156.850	All areas Intership, Ship/Shore, Commercial, Non-commercial and Ship Movement: All operations limited to 1-watt maximum power. May also be used for on-board communications.
18A	156.900	156.900	All areas Intership, Ship/Shore and Commercial: Towing on the Pacific Coast.
19A	156.950	156.950	All areas except PC Intership and Ship/Shore: Canadian Coast Guard only.
19A	156.950	156.950	PC Intership and Ship/Shore: Various Government departments
20	157.000	161.600	All areas Ship/Shore, Safety and Ship Movement: Port operation
21A	157.050	157.050	All areas Intership and Ship/Shore: Canadian Coast Guard only.
21B	-	161.650	All areas Safety: Continuous Marine Broadcast (CMB) service. ³
22A	157.100	157.100	All areas Intership, Ship/Shore, Commercial and Non-commercial: For communications between Canadian Coast Guard and non-Canadian Coast Guard stations only.
23	157.150	161.750	PC Ship/Shore and Public Correspondence: Also in the inland waters of British Columbia and the Yukon.
24	157.200	161.800	All areas Ship/Shore and Public Correspondence
25	157.250	161.850	PC Ship/Shore and Public Correspondence: Also assigned for operations in the Lake Winnipeg area.
25B	-	161.850	AC Safety: Continuous Marine Broadcast (CMB) service.
26	157.300	161.900	All areas Ship/Shore, Safety and Public Correspondence
27	157.350	161.950	AC, GL, PC Ship/Shore and Public Correspondence
28	157.400	162.000	PC Ship/Shore, Safety and Public Correspondence
28B	-	162.000	AC Safety: Continuous Marine Broadcast (CMB) service.
60	156.025	160.625	PC Ship/Shore and Public Correspondence
61A	156.075	156.075	PC Intership and Ship/Shore: Canadian Coast Guard only.
61A	156.075	156.075	EC Intership, Ship/Shore and Commercial: Commercial fishing only.
62A	156.125	156.125	PC Intership and Ship/Shore: Canadian Coast Guard only.
62A	156.125	156.125	EC Intership, Ship/Shore and Commercial: Commercial fishing only.
64	156.225	160.825	PC Ship/Shore and Public Correspondence
64A	156.225	156.225	EC Intership, Ship/Shore and Commercial: Commercial fishing only.
65A	156.275	156.275	Intership, Ship/Shore, Commercial, Non-commercial, Safety: Search & rescue and antipollution operations on the Great Lakes. Towing on the Pacific Coast. Port operations only in the St. Lawrence River areas with 1W maximum power. Pleasure craft in the inland waters of Alberta,

66A	156.325	156.325	Saskatchewan and Manitoba (excluding Lake Winnipeg and the Red River). Intership, Ship/Shore, Commercial, Non-commercial, Safety and Ship Movement: Port operations only in the St. Lawrence River/Great Lakes Areas with 1-watt maximum power.
67	156.375	156.375	EC Intership, Ship/Shore and Commercial: Commercial fishing only.
67	156.375	156.375	All areas except EC Intership, Ship/Shore, Commercial, Non-commercial, Safety: May also be used for communications with aircraft engaged in coordinated search and rescue and antipollution operations.
68	156.425	156.425	All areas Intership, Ship/Shore and Non-commercial: For marinas and yacht clubs.
69	156.475	156.475	All areas except EC Intership, Ship/Shore, Commercial and Non-commercial
69	156.475	156.475	EC Intership, Ship/Shore and Commercial: Commercial fishing only.
71	156.575	156.575	PC Intership, Ship/Shore, Commercial, Non-commercial, Safety and Ship Movement
71	156.575	156.575	Intership, Ship/Shore and Non-commercial: For marinas and yacht clubs on the East Coast and on Lake Winnipeg.
72	156.625	156.625	EC, PC Intership, Commercial and Non-commercial: May be used to communicate with aircraft and helicopters in predominantly maritime support operations.
73	156.675	156.675	EC Intership, Ship/Shore and Commercial: Commercial fishing only
73	156.675	156.675	All areas except EC Intership, Ship/Shore, Commercial, Non-commercial, Safety: May also be used for communications with aircraft engaged in coordinated search and rescue and antipollution operations.
74	156.725	156.725	EC, PC Intership, Ship/Shore, Commercial, Non-commercial and Ship Movement.
77	156.875	156.875	Intership, Ship/Shore, Safety and Ship Movement: Pilotage on Pacific Coast. Port operations only in the St. Lawrence River/Great Lakes areas with 1W maximum power.
78A	156.925	156.925	EC, PC Intership, Ship/Shore and Commercial
79A	156.975	156.975	EC, PC Intership, Ship/Shore and Commercial
80A	157.025	157.025	EC, PC Intership, Ship/Shore and Commercial
81A	157.075	157.075	Intership and Ship/Shore: Canadian Coast Guard use only in the St. Lawrence River/Great Lakes areas.
81A	157.075	157.075	PC Intership, Ship/Shore and Safety: Canadian Coast Guard antipollution.
82A	157.125	157.125	PC Intership, Ship/Shore and Safety: Canadian Coast Guard use only.
82A	157.125	157.125	Intership and Ship/Shore: Canadian Coast Guard use only in the St. Lawrence River/Great Lakes areas.
83	157.175	161.775	PC Ship/Shore and Safety: Canadian Coast Guard use only.
83A	157.175	157.175	EC Intership and Ship/Shore: Canadian Coast Guard and other Government agencies.
83B	-	161.775	AC, GL Safety: Continuous Marine Broadcast (CMB) Service.
84	157.225	161.825	PC Ship/Shore and Public Correspondence
85	157.275	161.875	AC, GL, NL Ship/Shore and Public Correspondence
86	157.325	161.925	PC Ship/Shore and Public Correspondence
87	157.375	161.975	AC, GL, NL Ship/Shore and Public Correspondence
88	157.425	162.025	AC, GL, NL Ship/Shore and Public Correspondence

AC: Atlantic Coast, Gulf and St. Lawrence River up to and including Montreal

EC (East Coast): includes NL, AC, GL and Eastern Arctic areas

GL: Great Lakes (including St. Lawrence above Montreal)

NL: Newfoundland and Labrador

PC: Pacific Coast

WC (West Coast): Pacific Coast, Western Arctic and Athabasca-Mackenzie Watershed areas

All areas: includes East and West Coast areas

Notes:

1. An "A" following a channel number indicates simplex use of the ship station transmit side of an international duplex channel. Operations are different from that of international operations on that channel.
2. Channel 16 is used for calling other stations or for distress alerting.
3. The letter "B" following a channel number indicates simplex use of the coast station transmit side of an international duplex channel. That is, the channel is Receive Only.
4. Channel 70 is used exclusively for Digital Selective Calling (DSC) and is not available for regular voice communications.
5. Channels 75 and 76 are reserved as guard bands for Channel 16 and are not available for regular voice communications.

European Private Channels and Frequencies

In addition to the channels listed above in the International Marine VHF Channels & Frequencies table, your radio may also include some of the following private channels. Which channels are included depend upon the country in which the radio is to be operated and whether you possess the appropriate licensing.

Country	CH No.	XMIT Freq	RCV Freq	Freq Use
Belgium	96	162.425	162.425	Marina
Denmark	L1	155.500	155.500	Leisure
	L2	155.525	155.525	Leisure
Denmark, Finland, Norway & Sweden	F1	155.625	155.625	Fishing
	F2	155.775	155.775	Fishing
	F3	155.825	155.825	Fishing
Finland, Norway&Sweden	L1	155.500	155.500	Leisure
	L2	155.525	155.525	Leisure
	L3	155.650	155.650	Leisure
Netherlands	31	157.550	162.150	Marina
	37	157.850	157.850	Leisure
UK	M1	157.850	157.850	Marina
	M2	161.425	161.425	Marina

Note: A license may be required to operate the radio on the private channels. It is your responsibility to obtain the proper license to operate the radio on these frequencies.