

DATE	DESCRIPTION	REV.
10.08.13	CHANGE AS PER ECN 13-091	A
3.30.17	CHANGE AS PER ECN 17-028	B

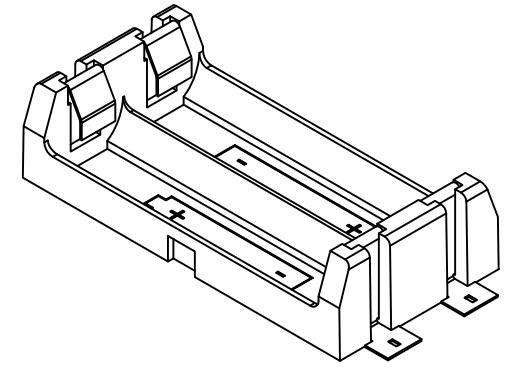
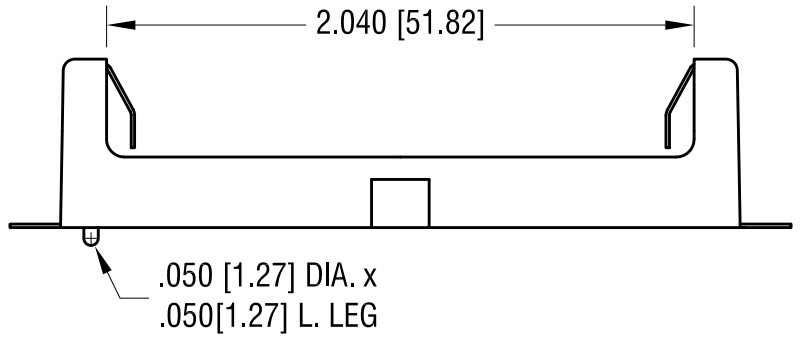
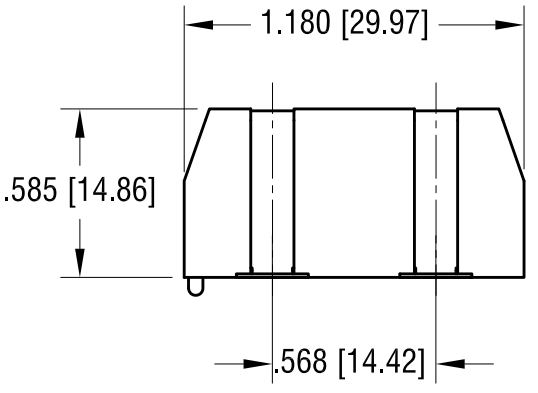
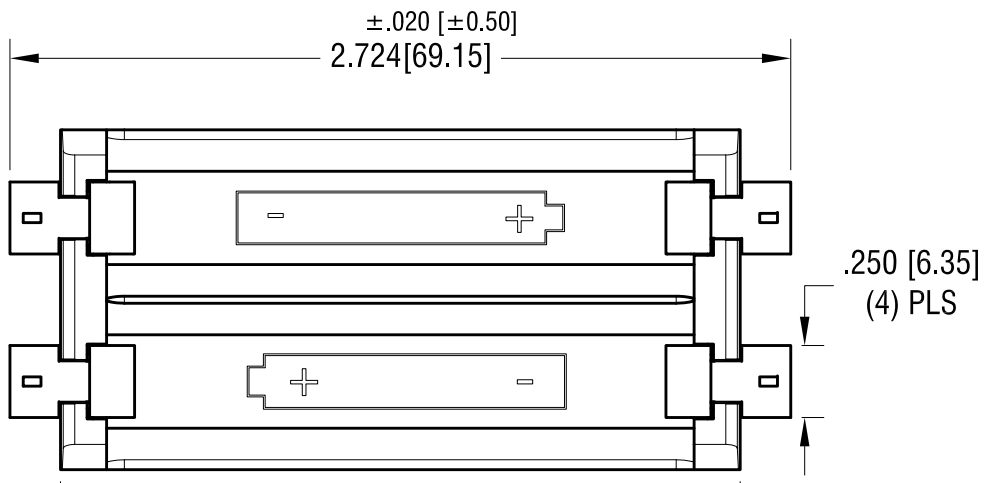
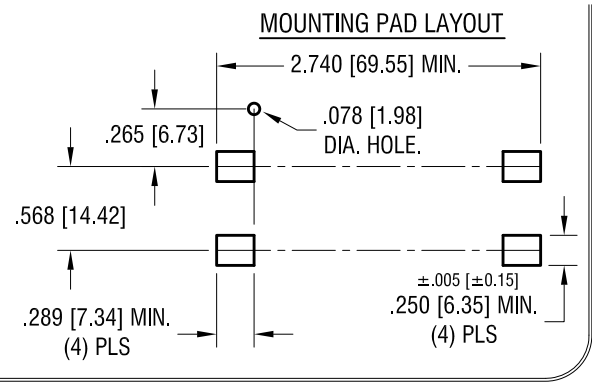

NOTE:
 1. BASE:
 MAT'L: HEAT RESISTANCE NYLON
 (UL 94V-0)
 2. CONTACT:
 MAT'L: .012 [0.30] THK STAINLESS STEEL
 FINISH: GOLD FLASH, OVER NICKEL PLATE.

THIS DOCUMENT IS THE PROPERTY OF KEYSTONE ELECTRONICS CORP. AND SHALL NOT BE REPRODUCED, DISTRIBUTED OR USED AS A BASIS FOR MANUFACTURE WITHOUT PRIOR WRITTEN PERMISSION FROM KEYSTONE ELECTRONICS CORP.

KEYSTONE ELECTRONICS CORP.			
www.keyelco.com • ASTORIA, N.Y. 11105-2017 • Tel (718) 956-8900			
PART NAME SM BATTERY HOLDER, (2) AA			
MATERIAL AS NOTED			
FINISH AS NOTED		DRN BY NT	DATE 5.18.10
		APPD LN	SCALE 1.5X
TOLERANCES DECIMAL ANGULAR	INCH [MM] ± .010 [± 0.25] ± 1°	CODE C	DWG NO. 1012
UNLESS OTHERWISE SPECIFIED			