

DATE	DESCRIPTION	REV.
9.14.14	CHANGE AS PER ECN 14-097	A

MOUNTING PAD LAYOUT

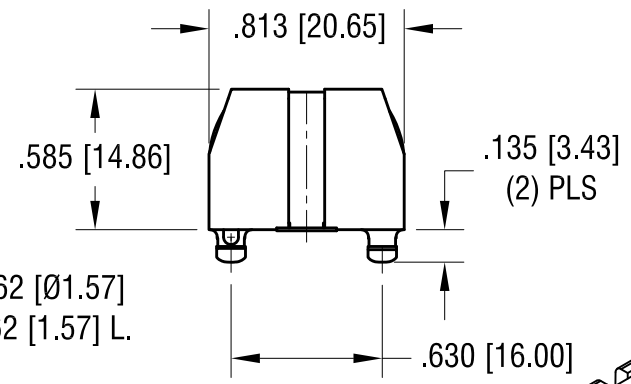

Ø.062 [Ø1.57]
x .062 [1.57] L.

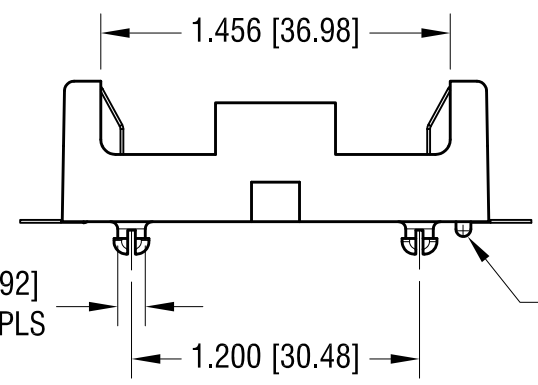
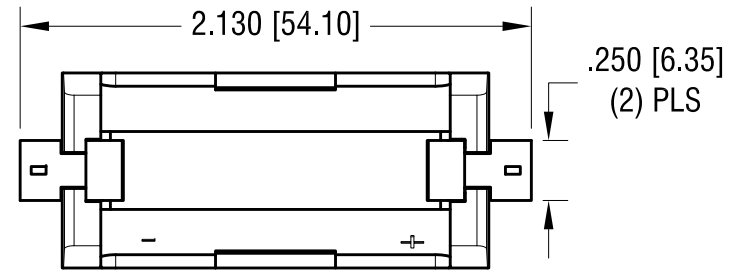
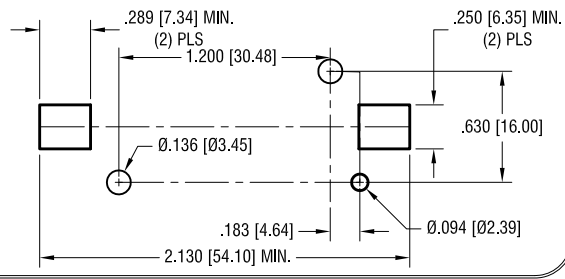
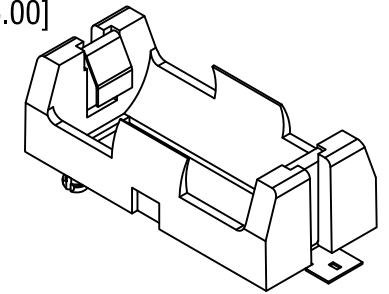
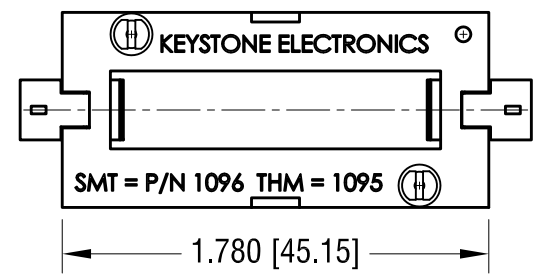

ACTUAL SIZE

NOTE:

- BASE:
MAT'L: HEAT RESISTANCE NYLON
STANYL 46 OR EQUIVALENT
- CONTACT:
MAT'L: .012 [0.30] THK STAINLESS STEEL
FINISH: GOLD FLASH, OVER NICKEL PLATE

KEYSTONE ELECTRONICS CORP.			
www.keyelco.com • ASTORIA, N.Y. 11105-2017 • Tel (718) 956-8900			
PART NAME			
PC BATTERY HOLDER , 18350			
MATERIAL			
AS NOTED			
FINISH	DRN BY	DATE	
AS NOTED	NT	7.30.14	
	APPD	SCALE	
	LN	1.25X	
TOLERANCES	INCH	[MM]	CODE
DECIMAL	± .010	[± 0.25]	C
ANGULAR	± 1°		DWG NO.
UNLESS OTHERWISE SPECIFIED			1096

THIS DOCUMENT IS THE PROPERTY OF KEYSTONE ELECTRONICS CORP. AND SHALL NOT BE REPRODUCED, DISTRIBUTED OR USED AS A BASIS FOR MANUFACTURE WITHOUT PRIOR WRITTEN PERMISSION FROM KEYSTONE ELECTRONICS CORP.