

Datasheet

Item no. 1566434, 1564999, 1565000, 1566435, 1565001,
1566436-1566438

V1_0917_01_en

Waterproof fan, IP 58 rating, 12V (0.5A, 0.16A , 0.08A, 0.37A); IP 58 rating, 24V, (0.13A, 0.09A, 0.21A, 0.26A)

Model no.: RD12038B12H

| | |
|---|--|
| 1 · Mechanical | |
| 1 1 · External dimension | 120*120*38mm |
| 1 2 · Weight | 246g/pcs (Lead wire length x 300mm & without connector) |
| 1 3 · Bearing | Two Ball bearing |
| 2 · Electrical characteristics(in free air at rated voltage) | |
| 2 1 · Rated voltage | 12V |
| 2 2 · Rated current | 0.5±10%A |
| 2 3 · Rated input power | 6.0±10%W |
| 3 · Efficiency | |
| 3 1 · Rated speed(range) | 2800RPM±10% |
| 3 2 · Maximum air flow | 113 99CFM |
| 3 3 · Maximum static air pressure | 8 66mm H2O |
| 4 · Characteristics | |
| 4 1 · Operating voltage range | 7.5V 13.8V |
| 4 2 · Starting voltage | 7.5V(ON/OFF) |
| 4 3 · Locked current | 0.55A(Reference) |
| 4 4 · Operating temperature | 10°C +70°C |
| 4 5 · Storage temperature | 30°C +85°C |
| 4 6 · Waterproof class | Grade IP58 to an immersion depth of 1.0 metre in water |
| 4 8 · Insulation resistance | At least 10M Ω at 500 VDC between housing and both lead wires |
| 4 9 · Dielectric strength | Withstand 500 VAC 1 minute 1mA between housing and both lead wires |
| 4 10 · MTBF : 50,000Hours | |
| Life expectancy:50,000Hours continuous operation at rated voltage and normal temperature & humidity | |
| 4 11 · Tensile strength of connector | Connector will not be any broken at 1 Kg for 15 seconds per piece |
| 4 12 · Accoustic sound level | 44 6dB A(Max 44 6dB A) |
| 4 12 1 · Accoustic sound level test descriptions | |

At rated voltage in sound proof room

Background noise:14.9dB A

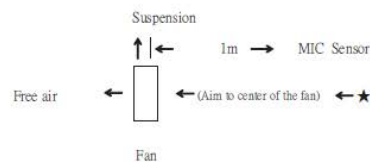

9 · Notes:

9 1 ·

We will not guarantee the products if the application of our products are exceeded the limitation which is specified on this specification

9 2 ·

In case of changes of the specification specified on this document A written notice is requested in advance

9 3 ·

Please do not touch the impeller with the pressure and never bring the fan with lead wire The bearing and lead wire may be damaged

9 4 ·

No guarantee on the products against the safety problem or failure caused by powder dust or insect

9 5 ·

If there is any data or related documentation different from this data sheet This data sheet is the principle reference

9 6 ·

Please do not use the fan in the environment of corrosive liquid or detrimental gas

9 7 ·

Please do not store the fan in the environment of high/low temperature or detrimental gas

9 8 ·

While the fan is in operation, please do not lock the fan intentionally for a long periods of time, since the continuous stoppage will result in overheat and thus burnt out the fan

9 9 ·

During the installation of the fan, please pay substantial attention to possible noise caused by resonance vibration and shock

9 10 ·

It is very important to notify that avoid to drop from 60cm height when in any movement or operation, it will impact the balance of blade. Especially ball bearing structure is avoided to drop down

9 11 ·

The torque of the screw which locked the frame should not exceed 4 Kgf

Datasheet

Item no. 1566434, 1564999, 1565000, 1566435, 1565001, 1566436-1566438

V1_0917_01_en

Waterproof fan, IP 58 rating, 12V (0.5A, 0.16A, 0.08A, 0.37A); IP 58 rating, 24V, (0.13A, 0.09A, 0.21A, 0.26A)

4.13 Characteristics definition:

- 4.13.1 Rated current, rated speed, and rated input power shall reach bottom line of specification after 5 minutes continuous rotation at rated voltage and reach standard specification after 10 minutes continuous at rated voltage
- 4.13.2 Starting voltage is the least voltage that enables to start the fan by sudden power on

5 Protection:

Reversal voltage test: We took 200pcs for reversal voltage test at 12V for 1 minutes and all remain still Fans work normally after corrected voltage

| | | | |
|----------|----|----|------|
| 6 Safety | UL | CE | RoHS |
| | | ✓ | ✓ |

7 Material

| Item | Major components | Material & Specification | Grade | Rmark |
|------|------------------------|---|-------------|--|
| 7.1 | Fan housing | PBT 70% + Fiber 30% | 94V 0 | |
| 7.2 | Fan blade | PBT 85% + Fiber 15% | 94V 0 | |
| 7.3 | Stator core | Stainless steel (SUS420J2) | | |
| 7.4 | Bearing | Ball bearing or sleeve bearing (Cu+GLY) 2100 | | Two Ball bearing |
| 7.5 | Rubber magnet | Strontium ferrite (BOB 14W) | | |
| 7.6 | Silicon steel strip | (H23) (H 8) | | |
| 7.7 | Enamelled copper wires | Material & Specification 0.22 0.23mm | MW 2 UEW | Heat resistance 120°C |
| 7.8 | Printed Circuit Board | Wiring printed single layer board | 94V 0 | CAM 1 T:0.8mm |
| 7.9 | Lead wires | Polyvinyl Chloride enamelled copper wires (AWG#22) | 94V 0 | Red wire: +polarity Black wire: -polarity |
| 7.10 | Label | Polyester | | |

8 Product inspection procedure

Inspection procedures below are extremely followed

8.1 100% Electric, rotating, dead spot, fan blade fasten, and primary noise test on production line

8.2 100% Current wave test with scope on production line

8.3 100% Strike test by hand and noise filter in quiet room

8.4 10 cm drop test at random in accordance with MIL STD 105E standard

8.5 Random inspection in accordance with MIL STD 105E standard

8.6 Pass/Reject standard:

Critical AQL:0.4 Major AQL:0.65 Minor AQL:1.0

10 RPM detection

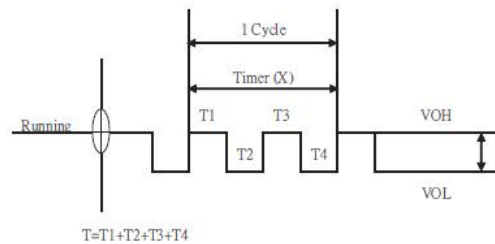

Voltage Strength(y)
(Magnetism Strength)

1 Output waveform: square wave

- 2 When the voltage value is higher (Voltage Y) then output waveform is higher
- 3 When the fan is shutdown then output waveform is a horizontal line
- 4 The cyclic distance is longer then the RPM is Slower
- 5 RPM formula as follows:

$$RPM = \frac{4200}{X(ns)}$$

Example

X=15ns

Ls=1000ns

Lmin=4200ns

$$RPM = \frac{4200}{15} = 2800$$

11 Installation drawing

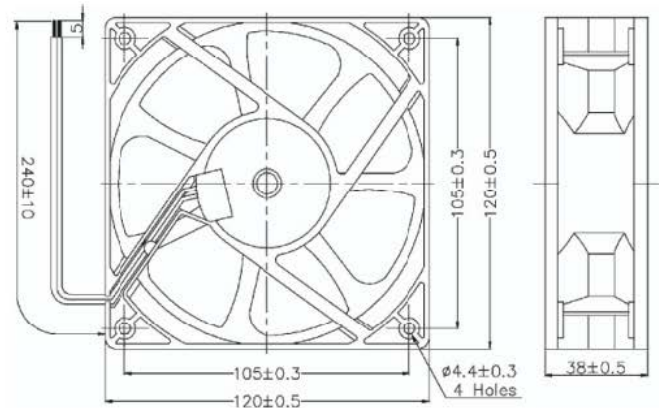

Unit:mm

This is a publication by Conrad Electronic SE, Klaus-Conrad-Str. 1, D-92240 Hirschau (www.conrad.com).

All rights including translation reserved. Reproduction by any method, e.g. photocopy, microfilming, or the capture in electronic data processing systems require the prior written approval by the editor. Reprinting, also in part, is prohibited. This publication represents the technical status at the time of printing.

© Copyright 2017 by Conrad Electronic SE.

Datasheet

Item no. 1566434, 1564999, 1565000, 1566435, 1565001,
1566436-1566438

V1_0917_01_en

Waterproof fan, IP 58 rating, 12V (0.5A, 0.16A , 0.08A, 0.37A); IP 58 rating, 24V, (0.13A, 0.09A, 0.21A, 0.26A)

Model no.: RD12038B12L1

| | |
|---|--|
| 1 · Mechanical | |
| 1.1 · External dimension | 120*120*38mm |
| 1.2 · Weight | 246g/pcs (Lead wire length x 300mm & without connector) |
| 1.3 · Bearing | Two Ball bearing |
| 2 · Electrical characteristics(in free air at rated voltage) | |
| 2.1 · Rated voltage | 12V |
| 2.2 · Rated current | 0.08±10%A |
| 2.3 · Rated input power | 0.96±10%W |
| 3 · Efficiency | |
| 3.1 · Rated speed(range) | 1500RPM±10% |
| 3.2 · Maximum air flow | 65.9CFM |
| 3.3 · Maximum static air pressure | 2.2mm H2O |
| 4 · Characteristics | |
| 4.1 · Operating voltage range | 7.5V-13.8V |
| 4.2 · Starting voltage | 7.5V(ON/OFF) |
| 4.3 · Locked current | 0.16A(Reference) |
| 4.4 · Operating temperature | 10°C-+70°C |
| 4.5 · Storage temperature | 30°C-+85°C |
| 4.6 · Waterproof class | Grade IP58 to an immersion depth of 1.0 metre in water |
| 4.8 · Insulation resistance | At least 10MΩ at 500 VDC between housing and both lead wires |
| 4.9 · Dielectric strength | Withstand 500 VAC 1 minute 1mA between housing and both lead wires |
| 4.10 · MTBF : 50,000Hours | |
| Life expectancy:50,000Hours continuous operation at rated voltage and normal temperature & humidity | |
| 4.11 · Tensile strength of connector | Connector will not be any broken at 1 Kg for 15 seconds per piece |
| 4.12 · Acoustic sound level | 27.0dBA(Max 27.0dBA) |
| 4.12.1 · Acoustic sound level test descriptions | |

At rated voltage in sound proof room
Background noise:14.9dBA

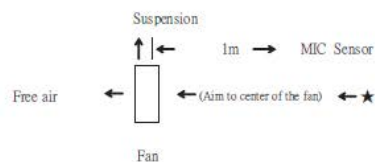

9 · Notes:

- 9.1 · We will not guarantee the products if the application of our products are exceeded the limitation which is specified on this specification
- 9.2 · In case of changes of the specification specified on this document A written notice is requested in advance
- 9.3 · Please do not touch the impeller with the pressure and never bring the fan with lead wire The bearing and lead wire may be damaged
- 9.4 · No guarantee on the products against the safety problem or failure caused by powder dust or insect
- 9.5 · If there is any data or related documentation different from this data sheet This data sheet is the principle reference
- 9.6 · Please do not use the fan in the environment of corrosive liquid or detrimental gas
- 9.7 · Please do not store the fan in the environment of high/low temperature or detrimental gas
- 9.8 · While the fan is in operation, please do not lock the fan intentionally for a long periods of time, since the continuous stoppage will result in overheat and thus burnt out the fan
- 9.9 · During the installation of the fan, please pay substantial attention to possible notice caused by resonance vibration and shock
- 9.10 · It is very important to notify that avoid to drop from 60cm height when in any movement or operation it will impact the balance of blade Especially ball bearing structure is avoided to drop down
- 9.11 · The torque of the screw which locked the frame should not exceed 4 Kgf

Datasheet

Item no. 1566434, 1564999, 1565000, 1566435, 1565001, 1566436-1566438

V1_0917_01_en

Waterproof fan, IP 58 rating, 12V (0.5A, 0.16A , 0.08A, 0.37A); IP 58 rating, 24V, (0.13A, 0.09A, 0.21A, 0.26A)

4.13 · Characteristics definition:

4.13.1 · Rated current, rated speed, and rated input power shall reach bottom line of specification after 5 minutes continuous rotation at rated voltage and reach standard specification after 10 minutes continuous at rated voltage

4.13.2 · Starting voltage is the least voltage that enables to start the fan by sudden power on

5 · Protection:

Reversal voltage test: We took 200pcs for reversal voltage test at 12V for 1 minutes and all remain still Fans work normally after corrected voltage

| | | | |
|------------|----|----|------|
| 6 · Safety | UL | CE | RoHS |
| | | ✓ | ✓ |

7 · Material

| Item | Major components | Material & Specification | Grade | Remark |
|------|------------------------|---|-------------|---|
| 7.1 | Fan housing | PBT 70% + Fiber 30% | 94V 0 | |
| 7.2 | Fan blade | PBT 85% + Fiber 15% | 94V 0 | |
| 7.3 | Stator core | Stainless steel (SUS420J2) | | |
| 7.4 | Bearing | Ball bearing or sleeve bearing (C1+GL Y) 2100 | | Two Ball bearing |
| 7.5 | Rubber magnet | Strontium ferrite (BOB 14W) | | |
| 7.6 | Silicon steel strip | (H23) (H 8) | | |
| 7.7 | Enamelled copper wires | Material & Specification 0.22 0.23mm | MW 2 UEW | Heat resistance 120°C |
| 7.8 | Printed Circuit Board | Wiring printed single layer board | 94V 0 | CAM 1 T:0.8mm |
| 7.9 | Lead wires | Polyvinyl Chloride enamelled copper wires (AWG#22) | 94V 0 | Red wire: +polarity Black wire: polarity |
| 7.10 | Label | Polyester | | |

8 · Product inspection procedure

Inspection procedures below are extremely followed

8.1 · 100% Electric, rotating, dead spot, fan blade fasten, and primary noise test on production line

8.2 · 100% Current wave test with scope on production line

8.3 · 100% Strike test by hand and noise filter in quiet room

8.4 · 10 cm drop test at random in accordance with MIL STD 105E standard

8.5 · Random inspection in accordance with MIL STD 105E standard

8.6 · Pass/Reject standard:

Critical AQL:0.4 Major AQL:0.65 Minor AQL:1.0

10 · RPM detection

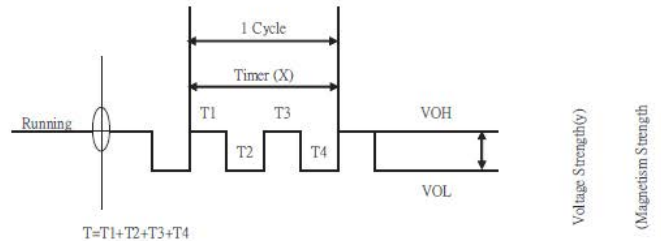

1 · Output waveform: square wave

2 · When the voltage value is higher (Voltage Y) then output waveform is higher

3 · When the fan is shutdown then output waveform is a horizontal line

4 · The cyclic distance is longer then the RPM is Slower

5 · RPM formula as follows:

$$RPM = \frac{2250}{X(ns)}$$

Example

X=15ns

Ls=1000ns

Lmin=22500ns

$$RPM = \frac{2250}{15} = 1500$$

11 · Installation drawing

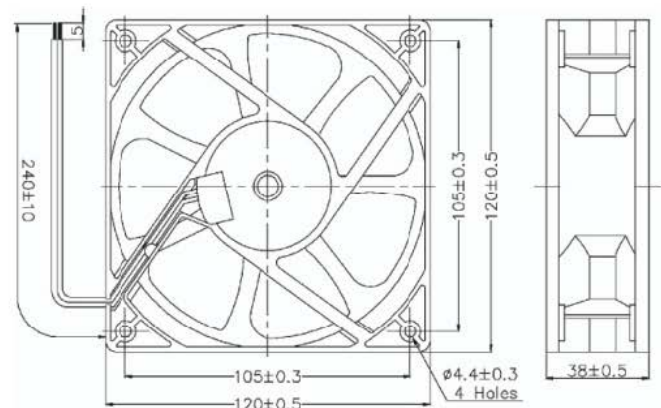

Unit:mm

This is a publication by Conrad Electronic SE, Klaus-Conrad-Str. 1, D-92240 Hirschau (www.conrad.com).

All rights including translation reserved. Reproduction by any method, e.g. photocopy, microfilming, or the capture in electronic data processing systems require the prior written approval by the editor. Reprinting, also in part, is prohibited. This publication represents the technical status at the time of printing.

© Copyright 2017 by Conrad Electronic SE.

Datasheet

Item no. 1566434, 1564999, 1565000, 1566435, 1565001,
1566436-1566438

V1_0917_01_en

Waterproof fan, IP 58 rating, 12V (0.5A, 0.16A , 0.08A, 0.37A); IP 58 rating, 24V, (0.13A, 0.09A, 0.21A, 0.26A)

Model no.: RD12038B12L

| | |
|--|--|
| 1 · Mechanical | |
| 1 1 · External dimension | 120*120*38mm |
| 1 2 · Weight | 246g/pcs (Lead wire length x 300mm & without connector) |
| 1 3 · Bearing | Two Ball bearing |
| 2 · Electrical characteristics(in free air at rated voltage) | |
| 2 1 · Rated voltage | 12V |
| 2 2 · Rated current | 0.16±10%A |
| 2 3 · Rated input power | 1.92±10%W |
| 3 · Efficiency | |
| 3 1 · Rated speed(range) | 1950RPM±10% |
| 3 2 · Maximum air flow | 83 6CFM |
| 3 3 · Maximum static air pressure | 4 72mm H2O |
| 4 · Characteristics | |
| 4 1 · Operating voltage range | 7.5V 13.8V |
| 4 2 · Starting voltage | 7.5V (ON/OFF) |
| 4 3 · Locked current | 0.24A (Reference) |
| 4 4 · Operating temperature | 10°C +70°C |
| 4 5 · Storage temperature | 30°C +85°C |
| 4 6 · Waterproof class | Grade IP58 to an immersion depth of 1.0 metre in water |
| 4 8 · Insulation resistance | At least 10MΩ at 500 VDC between housing and both lead wires |
| 4 9 · Dielectric strength | Withstand 500 VAC 1 minute 1mA between housing and both lead wires |
| 4 10 · MTBF : 50,000Hours | |
| Life expectancy: 50,000Hours continuous operation at rated voltage and normal temperature & humidity | |
| 4 11 · Tensile strength of connector | Connector will not be any broken at 1 Kg for 15 seconds per piece |
| 4 12 · Acoustic sound level | 34 0dBA(Max 34 0dBA) |
| 4 12 1 · Acoustic sound level test descriptions | |

At rated voltage in sound proof room
Background noise: 14.9dBA

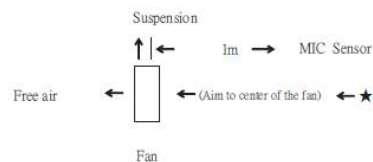

9 · Notes:

- 9 1 · We will not guarantee the products if the application of our products are exceeded the limitation which is specified on this specification
- 9 2 · In case of changes of the specification specified on this document A written notice is requested in advance
- 9 3 · Please do not touch the impeller with the pressure and never bring the fan with lead wire The bearing and lead wire may be damaged
- 9 4 · No guarantee on the products against the safety problem or failure caused by powder dust or insect
- 9 5 · If there is any data or related documentation different from this data sheet This data sheet is the principle reference
- 9 6 · Please do not use the fan in the environment of corrosive liquid or detrimental gas
- 9 7 · Please do not store the fan in the environment of high/low temperature or detrimental gas
- 9 8 · While the fan is in operation, please do not lock the fan intentionally for a long periods of time, since the continuous stoppage will result in overheat and thus burnt out the fan
- 9 9 · During the installation of the fan, please pay substantial attention to possible noise caused by resonance vibration and shock
- 9 10 · It is very important to notify that avoid to drop from 60cm height when in any movement or operation, it will impact the balance of blade Especially ball bearing structure is avoided to drop down
- 9 11 · The torque of the screw which locked the frame should not exceed 4 Kgf

Datasheet

Item no. 1566434, 1564999, 1565000, 1566435, 1565001, 1566436-1566438

V1_0917_01_en

Waterproof fan, IP 58 rating, 12V (0.5A, 0.16A , 0.08A, 0.37A); IP 58 rating, 24V, (0.13A, 0.09A, 0.21A, 0.26A)

4.13 Characteristics definition:

4.13.1 Rated current, rated speed, and rated input power shall reach bottom line of specification after 5 minutes continuous rotation at rated voltage and reach standard specification after 10 minutes continuous at rated voltage

4.13.2 Starting voltage is the least voltage that enables to start the fan by sudden power on

5 Protection:

Reversal voltage test: We took 200pcs for reversal voltage test at 12V for 1 minutes and all remain still Fans work normally after corrected voltage

| | | | |
|----------|----|----|------|
| 6 Safety | UL | CE | RoHS |
| | | ✓ | ✓ |

7 Material

| Item | Major components | Material & Specification | Grade | Remark |
|------|------------------------|--|----------|---|
| 7.1 | Fan housing | PBT 70% + Fiber 30% | 94V 0 | |
| 7.2 | Fan blade | PBT 85% + Fiber 15% | 94V 0 | |
| 7.3 | Stator core | Stainless steel (SUS420J2) | | |
| 7.4 | Bearing | Ball bearing or sleeve bearing (Cu+GLY) 2100 | | Two Ball bearing |
| 7.5 | Rubber magnet | Strontium ferrite (BOB 14W) | | |
| 7.6 | Silicon steel strip | (H23) (H 8) | | |
| 7.7 | Enamelled copper wires | Material & Specification 0.22 0.23mm | MW 2 UEW | Heat resistance 120°C |
| 7.8 | Printed Circuit Board | Wiring printed single layer board | 94V 0 | CAM 1 T:0.8mm |
| 7.9 | Lead wires | Polyvinyl Chloride enamelled copper wires (AWG#22) | 94V 0 | Red wire: polarity Black wire: polarity |
| 7.10 | Label | Polyester | | |

8 Product inspection procedure

Inspection procedures below are extremely followed

8.1 100% Electric, rotating, dead spot, fan blade fasten, and primary noise test on production line

8.2 100% Current wave test with scope on production line

8.3 100% Strike test by hand and noise filter in quiet room

8.4 10 cm drop test at random in accordance with MIL STD 105E standard

8.5 Random inspection in accordance with MIL STD 105E standard

8.6 Pass/Reject standard:

Critical AQL:0.4 Major AQL:0.65 Minor AQL:1.0

10 RPM detection

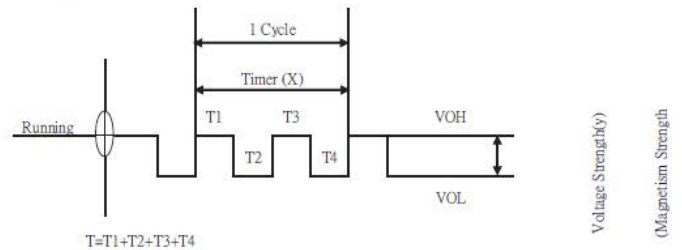

1 Output waveform: square wave

2 When the voltage value is higher (Voltage Y) then output waveform is higher

3 When the fan is shutdown then output waveform is a horizontal line

4 The cyclic distance is longer then the RPM is Slower

5 RPM formula as follows:

$$RPM = \frac{2925}{X(ns)}$$

Example

X=15ns

Ls=1000ns

Lmin=29250ns

$$RPM = \frac{2925}{15} = 1950$$

11 Installation drawing

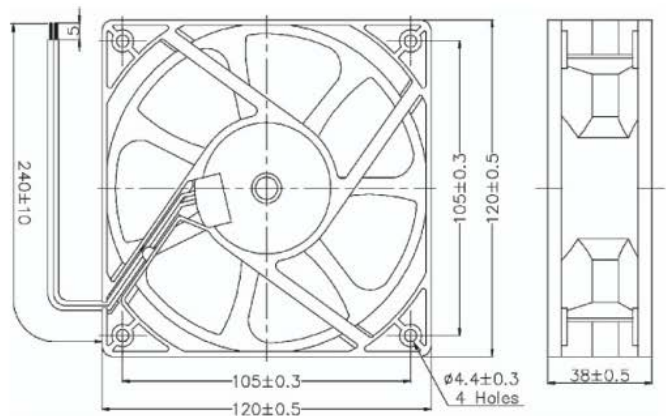

Unit:mm

This is a publication by Conrad Electronic SE, Klaus-Conrad-Str. 1, D-92240 Hirschau (www.conrad.com).

All rights including translation reserved. Reproduction by any method, e.g. photocopy, microfilming, or the capture in electronic data processing systems require the prior written approval by the editor. Reprinting, also in part, is prohibited. This publication represents the technical status at the time of printing.

© Copyright 2017 by Conrad Electronic SE.

Datasheet

Item no. 1566434, 1564999, 1565000, 1566435, 1565001,
1566436-1566438

V1_0917_01_en

Waterproof fan, IP 58 rating, 12V (0.5A, 0.16A , 0.08A, 0.37A); IP 58 rating, 24V, (0.13A, 0.09A, 0.21A, 0.26A)

Model no.: RD12038B12M

| | |
|--|--|
| 1 Mechanical | |
| 1.1 External dimension | 120*120*38mm |
| 1.2 Weight | 246g/pcs (Lead wire length x 300mm & without connector) |
| 1.3 Bearing | Two Ball bearing |
| 2 Electrical characteristics(in free air at rated voltage) | |
| 2.1 Rated voltage | 12V |
| 2.2 Rated current | 0.37±10%A |
| 2.3 Rated input power | 4.44±10%W |
| 3 Efficiency | |
| 3.1 Rated speed(range) | 2540RPM±10% |
| 3.2 Maximum air flow | 101.3CFM |
| 3.3 Maximum static air pressure | 7.66mm H ₂ O |
| 4 Characteristics | |
| 4.1 Operating voltage range | 7.5V 13.8V |
| 4.2 Starting voltage | 7.5V(ON/OFF) |
| 4.3 Locked current | 0.46A(Reference) |
| 4.4 Operating temperature | 10°C +70°C |
| 4.5 Storage temperature | 30°C +85°C |
| 4.6 Waterproof class | Grade IP58 to an immersion depth of 1.0 metre in water |
| 4.8 Insulation resistance | At least 10MΩ at 500 VDC between housing and both lead wires |
| 4.9 Dielectric strength | Withstand 500 VAC 1 minute 1mA between housing and both lead wires |
| 4.10 MTBF : 50,000Hours Life expectancy:50,000Hours continuous operation at rated voltage and normal temperature & humidity | |
| 4.11 Tensile strength of connector | Connector will not be any broken at 1 Kg for 15 seconds per piece |
| 4.12 Acoustic sound level | 41.0dBA(Max 41.0dBA) |
| 4.12.1 Acoustic sound level test descriptions | |

At rated voltage in sound proof room
Background noise:14.9dBA

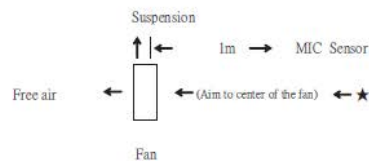

9 Notes:

- 9.1 We will not guarantee the products if the application of our products are exceeded the limitation which is specified on this specification
- 9.2 In case of changes of the specification specified on this document A written notice is requested in advance
- 9.3 Please do not touch the impeller with the pressure and never bring the fan with lead wire The bearing and lead wire may be damaged
- 9.4 No guarantee on the products against the safety problem or failure caused by powder dust or insect
- 9.5 If there is any data or related documentation different from this data sheet This data sheet is the principle reference
- 9.6 Please do not use the fan in the environment of corrosive liquid or detrimental gas
- 9.7 Please do not store the fan in the environment of high/low temperature or detrimental gas
- 9.8 While the fan is in operation, please do not lock the fan intentionally for a long periods of time, since the continuous stoppage will result in overheat and thus burnt out the fan
- 9.9 During the installation of the fan, please pay substantial attention to possible noise caused by resonance vibration and shock
- 9.10 It is very important to notify that avoid to drop from 60cm height when in any movement or operation, it will impact the balance of blade. Especially ball bearing structure is avoided to drop down
- 9.11 The torque of the screw which locked the frame should not exceed 4 Kgf

Datasheet

Item no. 1566434, 1564999, 1565000, 1566435, 1565001, 1566436-1566438

V1_0917_01_en

Waterproof fan, IP 58 rating, 12V (0.5A, 0.16A, 0.08A, 0.37A); IP 58 rating, 24V, (0.13A, 0.09A, 0.21A, 0.26A)

4.13 · Characteristics definition:

4.13.1 · Rated current, rated speed, and rated input power shall reach bottom line of specification after 5 minutes continuous rotation at rated voltage and reach standard specification after 10 minutes continuous at rated voltage

4.13.2 · Starting voltage is the least voltage that enables to start the fan by sudden power on

5 · Protection:

Reversal voltage test: We took 200pcs for reversal voltage test at 12V for 1 minutes and all remain still Fans work normally after corrected voltage

| | | | |
|------------|----|----|------|
| 6 · Safety | UL | CE | RoHS |
| | | ✓ | ✓ |

7 · Material

| Item | Major components | Material & Specification | Grade | Remark |
|------|------------------------|--|----------|---|
| 7.1 | Fan housing | PBT 70% + Fiber 30% | 94V 0 | |
| 7.2 | Fan blade | PBT 85% + Fiber 15% | 94V 0 | |
| 7.3 | Stator core | Stainless steel (SUS420J2) | | |
| 7.4 | Bearing | Ball bearing or sleeve bearing (Cu+GL Y) 2100 | | Two Ball bearing |
| 7.5 | Rubber magnet | Strontium ferrite (BQB 14W) | | |
| 7.6 | Silicon steel strip | (H23) (H 8) | | |
| 7.7 | Enamelled copper wires | Material & Specification 0.22 0.23mm | MW 2 UEW | Heat resistance 120°C |
| 7.8 | Printed Circuit Board | Wiring printed single layer board | 94V 0 | CAM 1 T:0.8mm |
| 7.9 | Lead wires | Polyvinyl Chloride enamelled copper wires (AWG#22) | 94V 0 | Red wire: + polarity Black wire: - polarity |
| 7.10 | Label | Polyester | | |

8 · Product inspection procedure

Inspection procedures below are extremely followed

- 8.1 · 100% Electric, rotating, dead spot, fan blade fasten, and primary noise test on production line
- 8.2 · 100% Current wave test with scope on production line
- 8.3 · 100% Strike test by hand and noise filter in quiet room
- 8.4 · 10 cm drop test at random in accordance with MIL STD 105E standard
- 8.5 · Random inspection in accordance with MIL STD 105E standard
- 8.6 · Pass/Reject standard:
Critical AQL:0.4 Major AQL:0.65 Minor AQL:1.0

10 · RPM detection

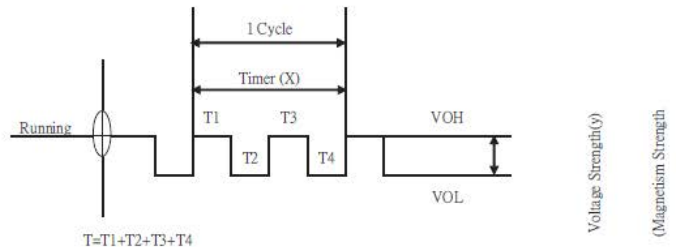

1 · Output waveform: square wave

- 2 · When the voltage value is higher (Voltage Y) then output waveform is higher
- 3 · When the fan is shutdown then output waveform is a horizontal line
- 4 · The cyclic distance is longer then the RPM is Slower
- 5 · RPM formula as follows:

$$RPM = \frac{3810}{X(ns)}$$

Example

X=15ns

LS=1000ns

Lmin=38100ns

$$RPM = \frac{3810}{15} = 2540$$

11 · Installation drawing

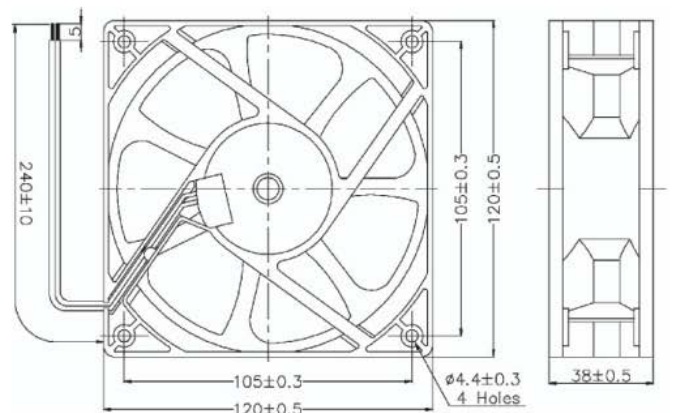

Unit:mm

This is a publication by Conrad Electronic SE, Klaus-Conrad-Str. 1, D-92240 Hirschau (www.conrad.com).

All rights including translation reserved. Reproduction by any method, e.g. photocopy, microfilming, or the capture in electronic data processing systems require the prior written approval by the editor. Reprinting, also in part, is prohibited. This publication represents the technical status at the time of printing.

© Copyright 2017 by Conrad Electronic SE.

Datasheet

Item no. 1566434, 1564999, 1565000, 1566435, 1565001,
1566436-1566438

V1_0917_01_en

Waterproof fan, IP 58 rating, 12V (0.5A, 0.16A , 0.08A, 0.37A); IP 58 rating, 24V, (0.13A, 0.09A, 0.21A, 0.26A)

Model no.: RD12038B24H

| | |
|---|--|
| 1 - Mechanical | |
| 1.1 - External dimension | 120*120*38mm |
| 1.2 - Weight | 246g/pcs (Lead wire length x 300mm & without connector) |
| 1.3 - Bearing | Two Ball bearing |
| 2 - Electrical characteristics(in free air at rated voltage) | |
| 2.1 - Rated voltage | 24V |
| 2.2 - Rated current | 0.26±10%A |
| 2.3 - Rated input power | 6.24±10%W |
| 3 - Efficiency | |
| 3.1 - Rated speed(range) | 2800RPM±10% |
| 3.2 - Maximum air flow | 113.99CFM |
| 3.3 - Maximum static air pressure | 8.66mm H2O |
| 4 - Characteristics | |
| 4.1 - Operating voltage range | 14V - 28V |
| 4.2 - Starting voltage | 14V(O/N/OFF) |
| 4.3 - Locked current | 0.31A(Reference) |
| 4.4 - Operating temperature | 10°C - +70°C |
| 4.5 - Storage temperature | 30°C - +85°C |
| 4.6 - Waterproof class | Grade IP58 to an immersion depth of 1.0 metre in water |
| 4.8 - Insulation resistance | At least 10MΩ at 500 VDC between housing and both lead wires |
| 4.9 - Dielectric strength | Withstand 500 VAC 1 minute 1mA between housing and both lead wires |
| 4.10 - MTBF : 50,000Hours | |
| Life expectancy:50,000Hours continuous operation at rated voltage and normal temperature & humidity | |
| 4.11 - Tensile strength of connector | Connector will not be any broken at 1 Kg for 15 seconds per piece |
| 4.12 - Acoustic sound level | 44.6dBA(Max 44.6dBA) |
| 4.12.1 - Acoustic sound level test descriptions | |

At rated voltage in sound proof room
Background noise:14.9dBA

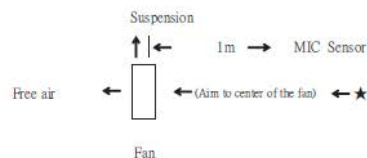

9 - Notes:

- 9.1 - We will not guarantee the products if the application of our products are exceeded the limitation which is specified on this specification
- 9.2 - In case of changes of the specification specified on this document A written notice is requested in advance
- 9.3 - Please do not touch the impeller with the pressure and never bring the fan with lead wire. The bearing and lead wire may be damaged
- 9.4 - No guarantee on the products against the safety problem or failure caused by powder dust or insect
- 9.5 - If there is any data or related documentation different from this data sheet This data sheet is the principle reference
- 9.6 - Please do not use the fan in the environment of corrosive liquid or detrimental gas
- 9.7 - Please do not store the fan in the environment of high/low temperature or detrimental gas
- 9.8 - While the fan is in operation, please do not lock the fan intentionally for a long periods of time, since the continuous stoppage will result in overheat and thus burnt out the fan
- 9.9 - During the installation of the fan, please pay substantial attention to possible noise caused by resonance vibration and shock
- 9.10 - It is very important to notify that avoid to drop from 60cm height when in any movement or operation, it will impact the balance of blade. Especially ball bearing structure is avoided to drop down
- 9.11 - The torque of the screw which locked the frame should not exceed 4 Kgf

Datasheet

Item no. 1566434, 1564999, 1565000, 1566435, 1565001, 1566436-1566438

V1_0917_01_en

Waterproof fan, IP 58 rating, 12V (0.5A, 0.16A , 0.08A, 0.37A); IP 58 rating, 24V, (0.13A, 0.09A, 0.21A, 0.26A)

4.13 · Characteristics definition:

4.13.1 · Rated current, rated speed, and rated input power shall reach bottom line of specification after 5 minutes continuous rotation at rated voltage and reach standard specification after 10 minutes continuous at rated voltage

4.13.2 · Starting voltage is the least voltage that enables to start the fan by sudden power on

5 · Protection:

Reversal voltage test: We took 200pcs for reversal voltage test at 24V for 1 minutes and all remain still Fans work normally after corrected voltage

| | | | |
|------------|----|----|------|
| 6 · Safety | UL | CE | RoHS |
| | | ✓ | ✓ |

7 · Material

| Item | Major components | Material & Specification | Grade | Remark |
|------|------------------------|--|----------|---|
| 7.1 | Fan housing | PBT 70% + Fiber 30% | 94V 0 | |
| 7.2 | Fan blade | PBT 85% + Fiber 15% | 94V 0 | |
| 7.3 | Stator core | Stainless steel (SUS420J2) | | |
| 7.4 | Bearing | Ball bearing or sleeve bearing (Cu+GLY) 2100 | | Two Ball bearing |
| 7.5 | Rubber magnet | Strontium ferrite (BOR 14W) | | |
| 7.6 | Silicon steel strip | (H23) (H 8) | | |
| 7.7 | Enamelled copper wires | Material & Specification 0.22 0.23mm | MW 2 UEW | Heat resistance 120°C |
| 7.8 | Printed Circuit Board | Wiring printed single layer board | 94V 0 | CAM 1 T:0.8mm |
| 7.9 | Lead wires | Polyvinyl Chloride enamelled copper wires (AWG#22) | 94V 0 | Red wire: polarity Black wire: polarity |
| 7.10 | Label | Polyester | | |

8 · Product inspection procedure

Inspection procedures below are extremely followed

8.1 · 100% Electric, rotating, dead spot, fan blade fasten, and primary noise test on production line

8.2 · 100% Current wave test with scope on production line

8.3 · 100% Strike test by hand and noise filter in quiet room

8.4 · 10 cm drop test at random in accordance with MIL STD 105E standard

8.5 · Random inspection in accordance with MIL STD 105E standard

8.6 · Pass/Reject standard:

Critical AQL:0.4 Major AQL:0.65 Minor AQL:1.0

10 · RPM detection

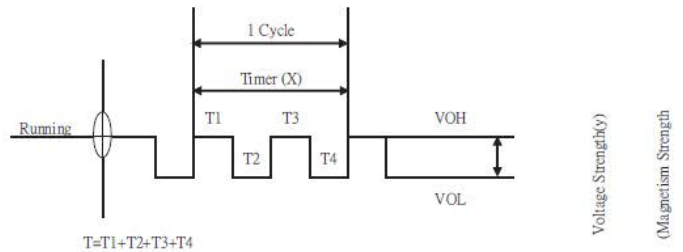

1 · Output waveform: square wave

2 · When the voltage value is higher (Voltage Y) then output waveform is higher

3 · When the fan is shutdown then output waveform is a horizontal line

4 · The cyclic distance is longer then the RPM is Slower

5 · RPM formula as follows:

$$RPM = \frac{4200}{X(ns)}$$

Example

X=15ns

Ls=1000ns

Lmin=42000ns

$$RPM = \frac{4200}{15} = 2800$$

11 · Installation drawing

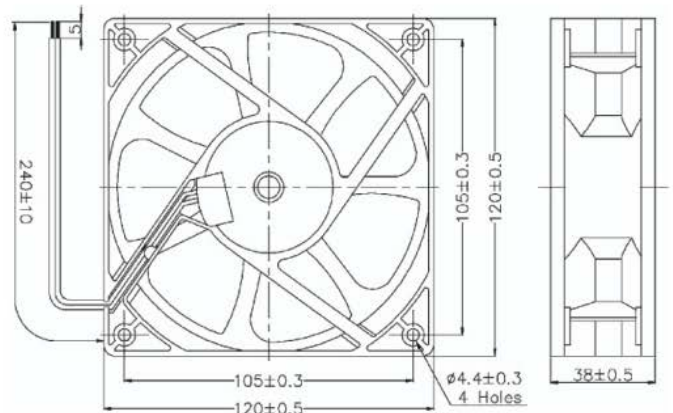

Unit:mm

This is a publication by Conrad Electronic SE, Klaus-Conrad-Str. 1, D-92240 Hirschau (www.conrad.com).

All rights including translation reserved. Reproduction by any method, e.g. photocopy, microfilming, or the capture in electronic data processing systems require the prior written approval by the editor. Reprinting, also in part, is prohibited. This publication represents the technical status at the time of printing.

© Copyright 2017 by Conrad Electronic SE.

Datasheet

Item no. 1566434, 1564999, 1565000, 1566435, 1565001,
1566436-1566438

V1_0917_01_en

Waterproof fan, IP 58 rating, 12V (0.5A, 0.16A , 0.08A, 0.37A); IP 58 rating, 24V, (0.13A, 0.09A, 0.21A, 0.26A)

Model no.: RD12038B24L1

| | |
|---|---|
| 1 · Mechanical | |
| 1 1 · External dimension | 120*120*38mm |
| 1 2 · Weight | 246g/pcs (Lead wire length x 300mm & without connector) |
| 1 3 · Bearing | Two Ball bearing |
| 2 · Electrical characteristics(in free air at rated voltage) | |
| 2 1 · Rated voltage | 24V |
| 2 2 · Rated current | 0.09±10%A |
| 2 3 · Rated input power | 2.16±10%W |
| 3 · Efficiency | |
| 3 1 · Rated speed(range) | 1500RPM±10% |
| 3 2 · Maximum air flow | 65.9CFM |
| 3 3 · Maximum static air pressure | 2.2mm H2O |
| 4 · Characteristics | |
| 4 1 · Operating voltage range | 14V-28V |
| 4 2 · Starting voltage | 14V(ON/OFF) |
| 4 3 · Locked current | 0.15A(Reference) |
| 4 4 · Operating temperature | 10°C-+70°C |
| 4 5 · Storage temperature | 30°C-+85°C |
| 4 6 · Waterproof class | Grade IP58 to an immersion depth of 1.0 metre in water |
| 4 8 · Insulation resistance | At least 10MΩ at 500 VDC between housing and both lead wires |
| 4 9 · Dielectric strength | Withstand 500 VAC 1 minute 1mA between housing and both lead wires |
| 4 10 · MTEF : 50,000Hours | Life expectancy:50,000Hours continuous operation at rated voltage and normal temperature & humidity |
| 4 11 · Tensile strength of connector | Connector will not be any broken at 1 Kg for 15 seconds per piece |
| 4 12 · Acoustic sound level | 27.0dBA(Max 27.0dBA) |
| 4 12 1 · Acoustic sound level test descriptions | |

At rated voltage in sound proof room
Background noise:14.9dBA

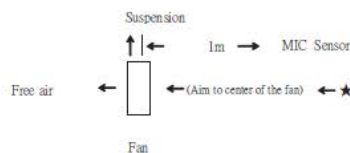

9 · Notes:

- 9 1 · We will not guarantee the products if the application of our products are exceeded the limitation which is specified on this specification
- 9 2 · In case of changes of the specification specified on this document A written notice is requested in advance
- 9 3 · Please do not touch the impeller with the pressure and never bring the fan with lead wire The bearing and lead wire may be damaged
- 9 4 · No guarantee on the products against the safety problem or failure caused by powder dust or insect
- 9 5 · If there is any data or related documentation different from this data sheet This data sheet is the principle reference
- 9 6 · Please do not use the fan in the environment of corrosive liquid or detrimental gas
- 9 7 · Please do not store the fan in the environment of high/low temperature or detrimental gas
- 9 8 · While the fan is in operation, please do not lock the fan intentionally for a long periods of time, since the continuous stoppage will result in overheat and thus burnt out the fan
- 9 9 · During the installation of the fan, please pay substantial attention to possible noise caused by resonance vibration and shock
- 9 10 · It is very important to notify that avoid to drop from 60cm height when in any movement or operation, it will impact the balance of blade Especially ball bearing structure is avoided to drop down
- 9 11 · The torque of the screw which locked the frame should not exceed 4 Kgf

Datasheet

Item no. 1566434, 1564999, 1565000, 1566435, 1565001, 1566436-1566438

V1_0917_01_en

Waterproof fan, IP 58 rating, 12V (0.5A, 0.16A, 0.08A, 0.37A); IP 58 rating, 24V, (0.13A, 0.09A, 0.21A, 0.26A)

4.13 Characteristics definition:

4.13.1 · Rated current, rated speed, and rated input power shall reach bottom line of specification after 5 minutes continuous rotation at rated voltage and reach standard specification after 10 minutes continuous at rated voltage

4.13.2 · Starting voltage is the least voltage that enables to start the fan by sudden power on

5 Protection:

Reversal voltage test: We took 200pcs for reversal voltage test at 24V for 1 minutes and all remain still Fans work normally after corrected voltage

| | | | |
|----------|----|----|------|
| 6 Safety | UL | CE | RoHS |
| | | ✓ | ✓ |

7 Material

| Item | Major components | Material & Specification | Grade | Remark |
|------|------------------------|--|----------|---|
| 7.1 | Fan housing | PBT 70% + Fiber 30% | 94V 0 | |
| 7.2 | Fan blade | PBT 85% + Fiber 15% | 94V 0 | |
| 7.3 | Stator core | Stainless steel (SUS420J2) | | |
| 7.4 | Bearing | Ball bearing or sleeve bearing (Cu+GLY) 2100 | | Two Ball bearing |
| 7.5 | Rubber magnet | Strontium ferrite (BOB 14W) | | |
| 7.6 | Silicon steel strip | (H23) (H 8) | | |
| 7.7 | Enamelled copper wires | Material & Specification 0.22 0.23mm | MW 2 UEW | Heat resistance 120°C |
| 7.8 | Printed Circuit Board | Wiring printed single layer board | 94V 0 | CAM 1 T:0.8mm |
| 7.9 | Lead wires | Polyvinyl Chloride enamelled copper wires (AWG#22) | 94V 0 | Red wire: + polarity Black wire: - polarity |
| 7.10 | Label | Polyester | | |

8 Product inspection procedure

Inspection procedures below are extremely followed

8.1 · 100% Electric, rotating, dead spot, fan blade fasten, and primary noise test on production line

8.2 · 100% Current wave test with scope on production line

8.3 · 100% Strike test by hand and noise filter in quiet room

8.4 · 10 cm drop test at random in accordance with MIL STD 105E standard

8.5 · Random inspection in accordance with MIL STD 105E standard

8.6 · Pass/Reject standard:

Critical AQL:0.4 Major AQL:0.65 Minor AQL:1.0

10 RPM detection

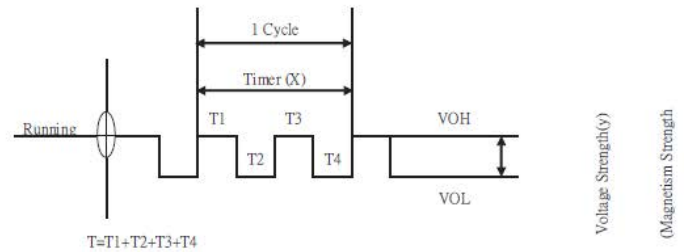

1 · Output waveform: square wave

2 · When the voltage value is higher (Voltage Y) then output waveform is higher

3 · When the fan is shutdown then output waveform is a horizontal line

4 · The cyclic distance is longer then the RPM is Slower

5 · RPM formula as follows:

$$RPM = \frac{2250}{X(ns)}$$

Example

X=15ns

LS=1000ns

Lmin=22500ns

$$RPM = \frac{2250}{15} = 1500$$

11 Installation drawing

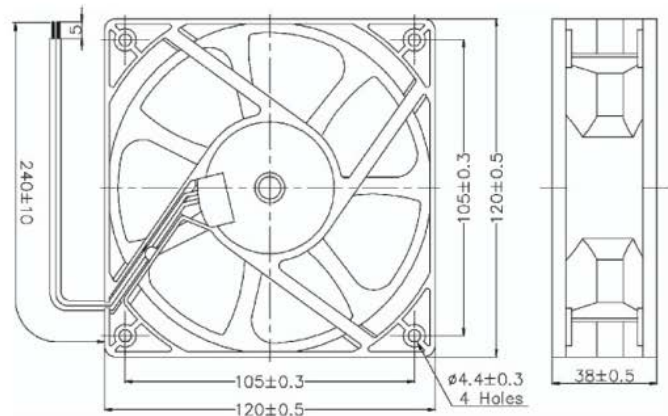

Unit:mm

This is a publication by Conrad Electronic SE, Klaus-Conrad-Str. 1, D-92240 Hirschau (www.conrad.com).

All rights including translation reserved. Reproduction by any method, e.g. photocopy, microfilming, or the capture in electronic data processing systems require the prior written approval by the editor. Reprinting, also in part, is prohibited. This publication represents the technical status at the time of printing.

© Copyright 2017 by Conrad Electronic SE.

Datasheet

Item no. 1566434, 1564999, 1565000, 1566435, 1565001,
1566436-1566438

V1_0917_01_en

Waterproof fan, IP 58 rating, 12V (0.5A, 0.16A , 0.08A, 0.37A); IP 58 rating, 24V, (0.13A, 0.09A, 0.21A, 0.26A)

Model no. : RD12038B24L

| | |
|---|--|
| 1 • Mechanical | |
| 1 1 • External dimension | 120*120*38mm |
| 1 2 • Weight | 246g/pcs (Lead wire length x 300mm & without connector) |
| 1 3 • Bearing | Two Ball bearing |
| 2 • Electrical characteristics(in free air at rated voltage) | |
| 2 1 • Rated voltage | 24V |
| 2 2 • Rated current | 0.13±10%A |
| 2 3 • Rated input power | 3.12±10%W |
| 3 • Efficiency | |
| 3 1 • Rated speed(range) | 1950RPM±10% |
| 3 2 • Maximum air flow | 83 CFM |
| 3 3 • Maximum static air pressure | 4.72mm H2O |
| 4 • Characteristics | |
| 4 1 • Operating voltage range | 14V-28V |
| 4 2 • Starting voltage | 14V(ON/OFF) |
| 4 3 • Locked current | 0.22A(Reference) |
| 4 4 • Operating temperature | 10°C +70°C |
| 4 5 • Storage temperature | 30°C +85°C |
| 4 6 • Waterproof class | Grade IP58 to an immersion depth of 1.0 metre in water |
| 4 8 • Insulation resistance | At least 10MΩ at 500 VDC between housing and both lead wires |
| 4 9 • Dielectric strength | Withstand 500 VAC 1 minute 1mA between housing and both lead wires |
| 4 10 • MTBF : 50,000Hours | |
| Life expectancy:50,000Hours continuous operation at rated voltage and normal temperature & humidity | |
| 4 11 • Tensile strength of connector | Connector will not be any broken at 1 Kg for 15 seconds per piece |
| 4 12 • Acoustic sound level | 34.0dBA(Max 34.0dBA) |
| 4 12 1 • Acoustic sound level test descriptions | |

At rated voltage in sound proof room
Background noise:14.9dBA

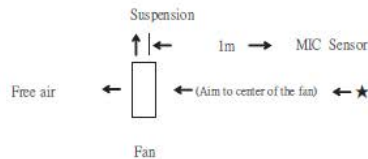

9 • Notes:

- 9 1 • We will not guarantee the products if the application of our products are exceeded the limitation which is specified on this specification
- 9 2 • In case of changes of the specification specified on this document A written notice is requested in advance
- 9 3 • Please do not touch the impeller with the pressure and never bring the fan with lead wire The bearing and lead wire may be damaged
- 9 4 • No guarantee on the products against the safety problem or failure caused by powder dust or insect
- 9 5 • If there is any data or related documentation different from this data sheet This data sheet is the principle reference
- 9 6 • Please do not use the fan in the environment of corrosive liquid or detrimental gas
- 9 7 • Please do not store the fan in the environment of high/low temperature or detrimental gas
- 9 8 • While the fan is in operation, please do not lock the fan intentionally for a long periods of time, since the continuous stoppage will result in overheat and thus burnt out the fan
- 9 9 • During the installation of the fan, please pay substantial attention to possible noise caused by resonance vibration and shock
- 9 10 • It is very important to notify that avoid to drop from 60cm height when in any movement or operation, it will impact the balance of blade Especially ball bearing structure is avoided to drop down
- 9 11 • The torque of the screw which locked the frame should not exceed 4 Kgf

Datasheet

Item no. 1566434, 1564999, 1565000, 1566435, 1565001, 1566436-1566438

V1_0917_01_en

Waterproof fan, IP 58 rating, 12V (0.5A, 0.16A, 0.08A, 0.37A); IP 58 rating, 24V, (0.13A, 0.09A, 0.21A, 0.26A)

4.13 Characteristics definition:

4.13.1 Rated current, rated speed, and rated input power shall reach bottom line of specification after 5 minutes continuous rotation at rated voltage and reach standard specification after 10 minutes continuous at rated voltage

4.13.2 Starting voltage is the least voltage that enables to start the fan by sudden power on

5 Protection:

Reversal voltage test: We took 200pcs for reversal voltage test at 24V for 1 minutes and all remain still Fans work normally after corrected voltage

| | | | |
|----------|----|----|------|
| 6 Safety | UL | CE | RoHS |
| | | ✓ | ✓ |

7 Material

| Item | Major components | Material & Specification | Grade | Remark |
|------|------------------------|--|----------|---|
| 7.1 | Fan housing | PBT 70% + Fiber 30% | 94V 0 | |
| 7.2 | Fan blade | PBT 85% + Fiber 15% | 94V 0 | |
| 7.3 | Stator core | Stainless steel (SUS420J2) | | |
| 7.4 | Bearing | Ball bearing or sleeve bearing (Cu+GL Y) 2100 | | Two Ball bearing |
| 7.5 | Rubber magnet | Strontium ferrite (BQB 14W) | | |
| 7.6 | Silicon steel strip | (H23) (H 8) | | |
| 7.7 | Enamelled copper wires | Material & Specification 0.22 0.23mm | MW 2 UEW | Heat resistance 120°C |
| 7.8 | Printed Circuit Board | Wiring printed single layer board | 94V 0 | CAM 1 T:0.8mm |
| 7.9 | Lead wires | Polyvinyl Chloride enamelled copper wires (AWG#22) | 94V 0 | Red wire: polarity Black wire: polarity |
| 7.10 | Label | Polyester | | |

8 Product inspection procedure

Inspection procedures below are extremely followed

8.1 100% Electric, rotating, dead spot, fan blade fasten, and primary noise test on production line

8.2 100% Current wave test with scope on production line

8.3 100% Strike test by hand and noise filter in quiet room

8.4 10 cm drop test at random in accordance with MIL STD 105E standard

8.5 Random inspection in accordance with MIL STD 105E standard

8.6 Pass/Reject standard:

Critical AQL:0.4 Major AQL:0.65 Minor AQL:1.0

10 RPM detection

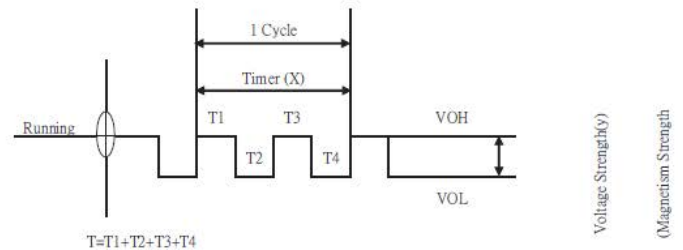

1 Output waveform:square wave

2 When the voltage value is higher (Voltage Y) then output waveform is higher

3 When the fan is shutdown then output waveform is a horizontal line

4 The cyclic distance is longer then the RPM is Slower

5 RPM formula as follows:

$$RPM = \frac{2925}{X(ns)}$$

Example

X=15ns

Ls=1000ns

Lmin=29250ns

$$RPM = \frac{2925}{15} = 1950$$

11 Installation drawing

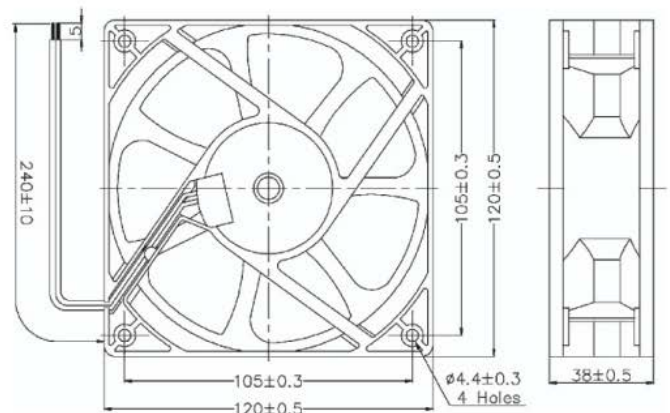

Unit:mm

This is a publication by Conrad Electronic SE, Klaus-Conrad-Str. 1, D-92240 Hirschau (www.conrad.com).

All rights including translation reserved. Reproduction by any method, e.g. photocopy, microfilming, or the capture in electronic data processing systems require the prior written approval by the editor. Reprinting, also in part, is prohibited. This publication represents the technical status at the time of printing.

© Copyright 2017 by Conrad Electronic SE.

Datasheet

Item no. 1566434, 1564999, 1565000, 1566435, 1565001,
1566436-1566438

V1_0917_01_en

Waterproof fan, IP 58 rating, 12V (0.5A, 0.16A , 0.08A, 0.37A); IP 58 rating, 24V, (0.13A, 0.09A, 0.21A, 0.26A)

Model no.: RD12038B24M

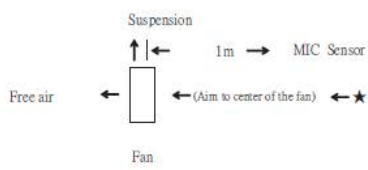
| | |
|---|---|
| 1 · Mechanical | |
| 1 1 · External dimension | 120*120*38mm |
| 1 2 · Weight | 246g/pcs (Lead wire length x 300mm & without connector) |
| 1 3 · Bearing | Two Ball bearing |
| 2 · Electrical characteristics(in free air at rated voltage) | |
| 2 1 · Rated voltage | 24V |
| 2 2 · Rated current | 0.21±10%A |
| 2 3 · Rated input power | 5.04±10%W |
| 3 · Efficiency | |
| 3 1 · Rated speed(range) | 2540RPM±10% |
| 3 2 · Maximum air flow | 101.3CFM |
| 3 3 · Maximum static air pressure | 7.66mm H2O |
| 4 · Characteristics | |
| 4 1 · Operating voltage range | 14V-28V |
| 4 2 · Starting voltage | 14V(ON/OFF) |
| 4 3 · Locked current | 0.36A(Reference) |
| 4 4 · Operating temperature | 10°C +70°C |
| 4 5 · Storage temperature | 30°C +85°C |
| 4 6 · Waterproof class | Grade IP58 to an immersion depth of 1.0 metre in water |
| 4 8 · Insulation resistance | At least 10MΩ at 500 VDC between housing and both lead wires |
| 4 9 · Dielectric strength | Withstand 500 VAC 1 minute 1mA between housing and both lead wires |
| 4 10 · MTBF : 50,000Hours | |
| | Life expectancy:50,000Hours continuous operation at rated voltage and normal temperature & humidity |
| 4 11 · Tensile strength of connector | Connector will not be any broken at 1 Kg for 15 seconds per piece |
| 4 12 · Acoustic sound level | 41.0dBA(Max 41.0dBA) |
| 4 12 1 · Acoustic sound level test descriptions | |
| At rated voltage in sound proof room | Suspension |
| Background noise:14.9dBA |  |

9 · Notes:

- 9 1 · We will not guarantee the products if the application of our products are exceeded the limitation which is specified on this specification
- 9 2 · In case of changes of the specification specified on this document A written notice is requested in advance
- 9 3 · Please do not touch the impeller with the pressure and never bring the fan with lead wire The bearing and lead wire may be damaged
- 9 4 · No guarantee on the products against the safety problem or failure caused by powder dust or insect
- 9 5 · If there is any data or related documentation different from this data sheet This data sheet is the principle reference
- 9 6 · Please do not use the fan in the environment of corrosive liquid or detrimental gas
- 9 7 · Please do not store the fan in the environment of high/low temperature or detrimental gas
- 9 8 · While the fan is in operation, please do not lock the fan intentionally for a long periods of time, since the continuous stoppage will result in overheat and thus burnt out the fan
- 9 9 · During the installation of the fan, please pay substantial attention to possible notice caused by resonance vibration and shock
- 9 10 · It is very important to notify that avoid to drop from 60cm height when in any movement or operation, it will impact the balance of blade. Especially ball bearing structure is avoided to drop down
- 9 11 · The torque of the screw which locked the frame should not exceed 4 Kgf

Datasheet

Item no. 1566434, 1564999, 1565000, 1566435, 1565001, 1566436-1566438

V1_0917_01_en

Waterproof fan, IP 58 rating, 12V (0.5A, 0.16A , 0.08A, 0.37A); IP 58 rating, 24V, (0.13A, 0.09A, 0.21A, 0.26A)

4.13 Characteristics definition:

4.13.1 Rated current, rated speed, and rated input power shall reach bottom line of specification after 5 minutes continuous rotation at rated voltage and reach standard specification after 10 minutes continuous at rated voltage

4.13.2 Starting voltage is the least voltage that enables to start the fan by sudden power on

5 Protection:

Reversal voltage test: We took 200pcs for reversal voltage test at 24V for 1 minutes and all remain still Fans work normally after corrected voltage

| | | | |
|----------|----|----|------|
| 6 Safety | UL | CE | RoHS |
| | | ✓ | ✓ |

7 Material

| Item | Major components | Material & Specification | Grade | Remark |
|------|------------------------|--|----------|---|
| 7.1 | Fan housing | PBT 70% + Fiber 30% | 94V 0 | |
| 7.2 | Fan blade | PBT 85% + Fiber 15% | 94V 0 | |
| 7.3 | Stator core | Stainless steel (SUS420J2) | | |
| 7.4 | Bearing | Ball bearing or sleeve bearing (Cu+GLY) 2100 | | Two Ball bearing |
| 7.5 | Rubber magnet | Strontium ferrite (BOB 14W) | | |
| 7.6 | Silicon steel strip | (H23) (H 8) | | |
| 7.7 | Enamelled copper wires | Material & Specification 0.22 0.23mm | MW 2 UEW | Heat resistance 120°C |
| 7.8 | Printed Circuit Board | Wiring printed single layer board | 94V 0 | CAM 1 T:0.8mm |
| 7.9 | Lead wires | Polyvinyl Chloride enamelled copper wires (AWG#22) | 94V 0 | Red wire::polarity Black wire: polarity |
| 7.10 | Label | Polyester | | |

8 Product inspection procedure

Inspection procedures below are extremely followed

8.1 100% Electric, rotating, dead spot, fan blade fasten, and primary noise test on production line

8.2 100% Current wave test with scope on production line

8.3 100% Strike test by hand and noise filter in quiet room

8.4 10 cm drop test at random in accordance with MIL STD 105E standard

8.5 Random inspection in accordance with MIL STD 105E standard

8.6 Pass/Reject standard:

Critical AQL:0.4 Major AQL:0.65 Minor AQL:1.0

10 RPM detection

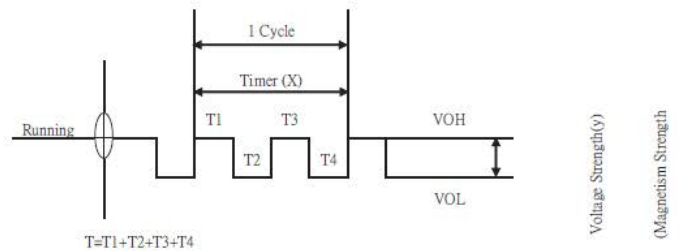

1 Output waveform:square wave

2 When the voltage value is higher (Voltage Y) then output waveform is higher

3 When the fan is shutdown then output waveform is a horizontal line

4 The cyclic distance is longer then the RPM is Slower

5 RPM formula as follows:

$$RPM = \frac{3810}{X(ns)}$$

Example

X=15ns

Ls=1000ns

Lmin=38100ns

$$RPM = \frac{3810}{15} = 2540$$

11 Installation drawing

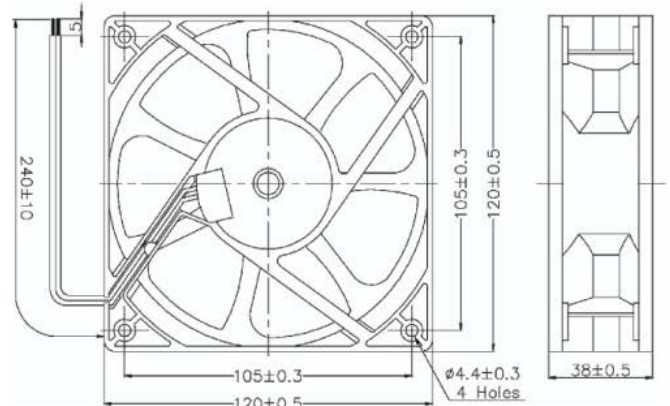

Unit:mm

This is a publication by Conrad Electronic SE, Klaus-Conrad-Str. 1, D-92240 Hirschau (www.conrad.com).

All rights including translation reserved. Reproduction by any method, e.g. photocopy, microfilming, or the capture in electronic data processing systems require the prior written approval by the editor. Reprinting, also in part, is prohibited. This publication represents the technical status at the time of printing.

© Copyright 2017 by Conrad Electronic SE.

Datasheet

Item no. 1566434, 1564999, 1565000, 1566435, 1565001, 1566436-1566438

V1_0917_01_en

**Waterproof fan, IP 58 rating, 12V (0.5A, 0.16A , 0.08A, 0.37A);
IP 58 rating, 24V, (0.13A, 0.09A, 0.21A, 0.26A)**

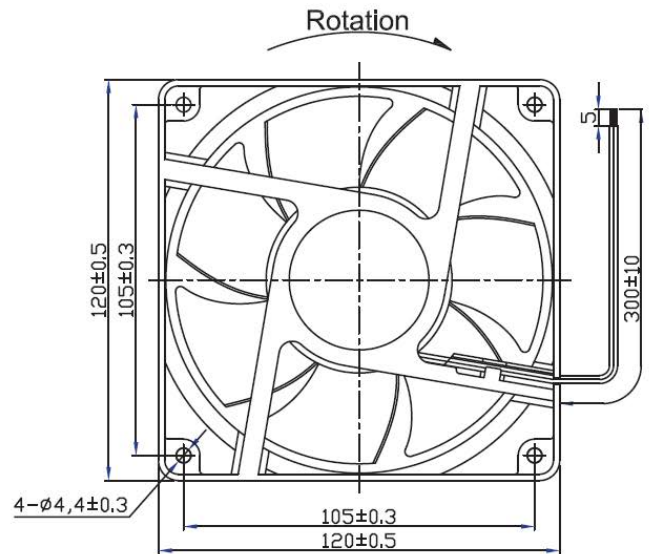
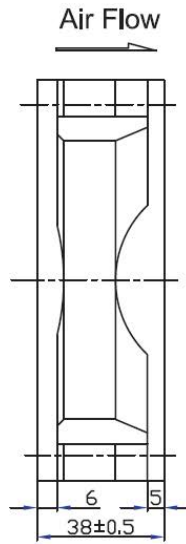
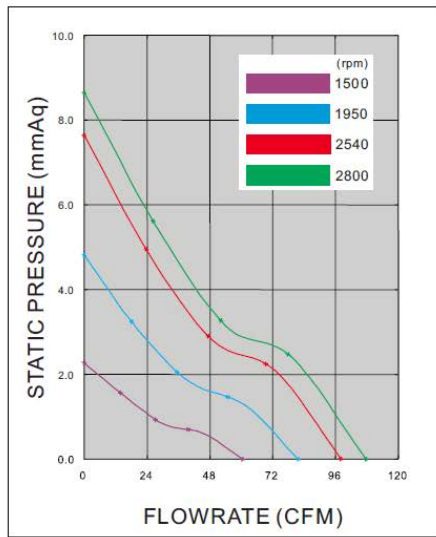

| Best-Nr. | Type | Rated Voltage (VDC) | Rated Current (A) | Rated Power (W) | Rated Speed (rpm) | Maximum AirFlow (CFM) | Maximum Pressure (mmAq) | Noise Level (dB/A) |
|----------|---------------------|---------------------|-------------------|-----------------|-------------------|-----------------------|-------------------------|--------------------|
| 1565000 | 189262 RD12038B12L1 | 12 | 0.08 | 0.96 | 1500 | 65.9 | 2.20 | 27.0 |
| 1564999 | 189261 RD12038B12L | 12 | 0.16 | 1.92 | 1950 | 83.6 | 4.72 | 34.0 |
| 1566435 | 189263 RD12038B12M | 12 | 0.37 | 4.44 | 2540 | 101.3 | 7.66 | 41.0 |
| 1566434 | 189259 RD12038B12H | 12 | 0.50 | 6.0 | 2800 | 113.99 | 8.66 | 44.6 |
| 1566436 | 189266 RD12038B24L1 | 24 | 0.09 | 2.16 | 1500 | 65.9 | 2.20 | 27.0 |
| 1565001 | 189264 RD12038B24L | 24 | 0.13 | 3.12 | 1950 | 83.6 | 4.72 | 34.0 |
| 1566437 | 189267 RD12038B24M | 24 | 0.21 | 5.04 | 2540 | 101.3 | 7.66 | 41.0 |
| 1566438 | 189268 RD12038B24H | 24 | 0.26 | 6.24 | 2800 | 113.99 | 8.66 | 44.6 |

Unit:mm

This is a publication by Conrad Electronic SE, Klaus-Conrad-Str. 1, D-92240 Hirschau (www.conrad.com). All rights including translation reserved. Reproduction by any method, e.g. photocopy, microfilming, or the capture in electronic data processing systems require the prior written approval by the editor. Reprinting, also in part, is prohibited. This publication represents the technical status at the time of printing.