

Data Sheet

Low power adapter 2.1 mm

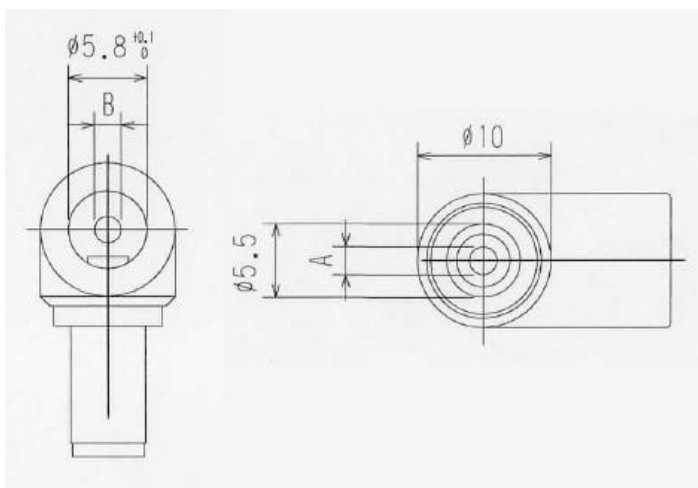
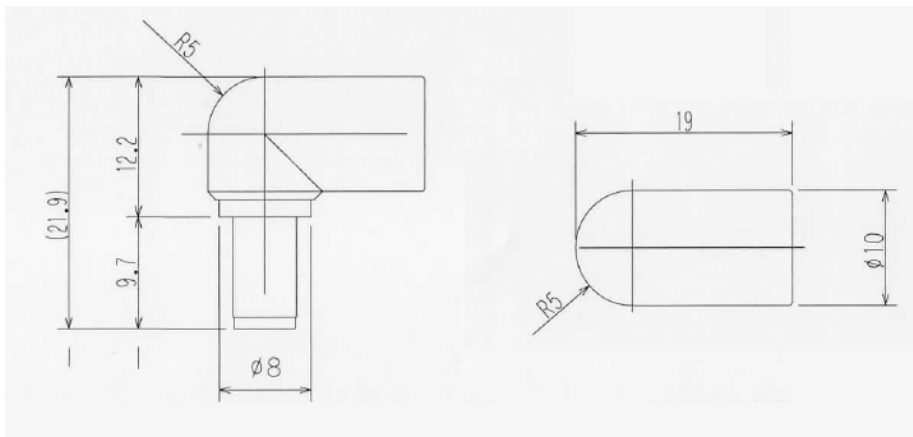
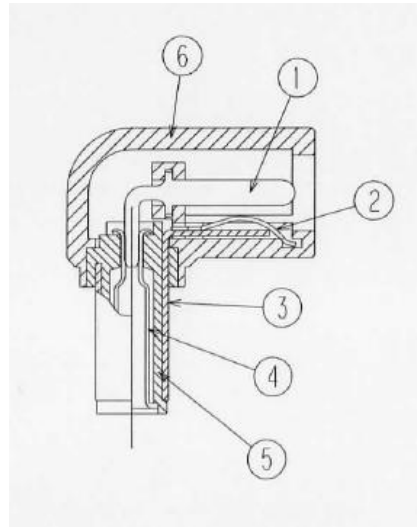

MODEL	A	B
MA-121SL	Ø2.1	Ø2.0
MA-122SL	Ø2.5	Ø2.35

Data Sheet

Technical data

- 1 Contact pin: Brass
- 2 Contact D: FAB
- 3 Contact C: Brass
- 4 Contact A: Brass
- 5 Insulation: ABS
- 6 Housing: ABS