

To.

DATE : 20 . . .

RoHS	Halogen Free
------	--------------

SPECIFICATION

PRODUCT : STARCAP

MODEL : DCLT Series



Langer Acker 32
30900 Wedemark
Germany

(+49) 5130 / 58642-0
info@amec-gmbh.de
www.amec-gmbh.de

WRITTEN	CHECKED	APPROVED

KORCHIP CORP.

KORCHIP B/D, 359, Manan-ro, Manan-gu, Anyang-si, Gyeonggi-do, KOREA

TEL : 82 - 31 - 361 - 8000

FAX : 82 - 31 - 361 - 8080

Index

Page No.	ITEM	etc.
1	Cover Page	
2	Index	
3	Revision History	
	Manufacturer Information	
4	1. Scope	
	2. Part Number System	
	3. Photo	
	4. General Specifications	
5-7	5. Product Construction and Dimension	
8	6. Reliability Specifications	
9	7. Packing Specifications	
	8. Labeling Standards	
10	9. Measuring Method of Characteristics	
11	10. Mounting	
12-13	11. Cautions for Use	
14	12. Environmental Management	

amec Langer Acker 32 (+49) 5130 / 58642-0
 40699 Düsseldorf, Germany info@amec-gmbh.de
 www.amec-gmbh.de

1. Scope

This specification applies to STARCAP(Electric Double Layer Capacitor), submitted to specified customer in cover page.

2. Part Number System

DCLT 3R6 105 V F (Example)
 ① ② ③ ④ ⑤

- ① Series Name : DC(Double layer capacitor - Coin type), L(Large size), T(high Temp.)
- ② Rated Voltage : 3.6VDC
- ③ Capacitance : 1.0 F (105 = $10 \times 10^{+5}$ uF)
- ④ Terminal Type : V-type
- ⑤ Pb-Free

3. Photo



4. General Specifications

ITEMS	DCLT3R6105	DCLT3R6155
Rated Voltage	3.6 VDC	3.6 VDC
Operating Temp.	-25 ~ +85 °C	-25 ~ +85 °C
Capacitance	1.0 F	1.5 F
Capacitance Tolerance	-20 ~ 80 %	-20 ~ 80 %
Equivalent Series Resistance (ESR)	Less than 30Ω	Less than 30Ω
Leakage Current (LC, 30min.)	Less than 1.5mA	Less than 1.5mA

5. Product Construction and Dimension (V-type)

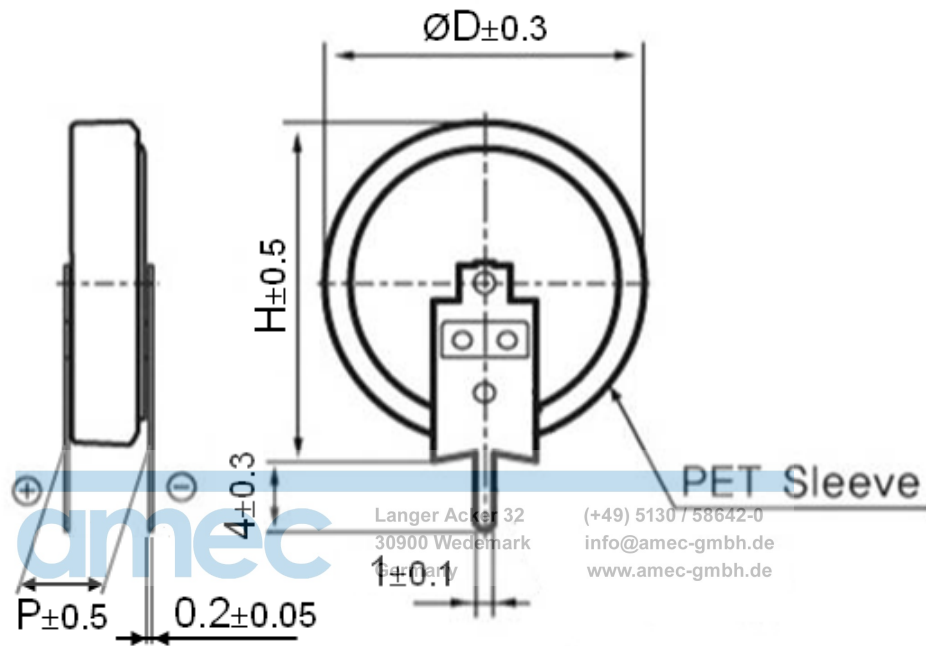

Part No.	Dimensions (mm)		
	ØD	H	P
DCLT3R6105VF	19.0	19.5	5.0
DCLT3R6155VF	19.0	19.5	5.0

5. Product Construction and Dimension (H-type)

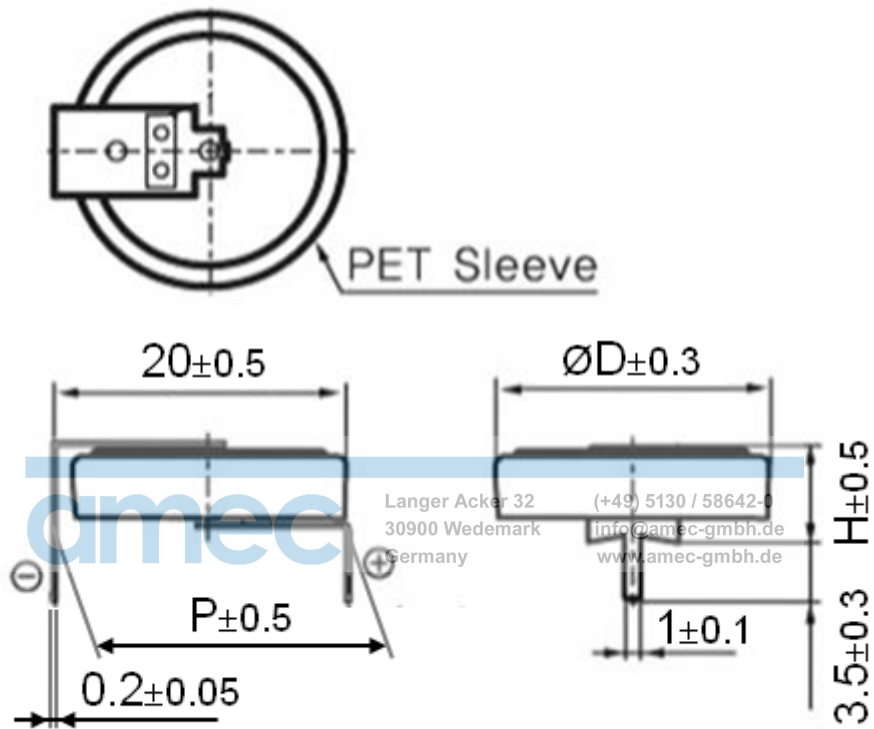

Langer Acker 32
30900 Wedemark
Germany
(+49) 5130 / 58642-0
info@amec-gmbh.de
www.amec-gmbh.de

Part No.	Dimensions (mm)		
	ØD	H	P
DCLT3R6105HF	19.0	6.5	20.0
DCLT3R6155HF	19.0	6.5	20.0

5. Product Construction and Dimension (C-type)

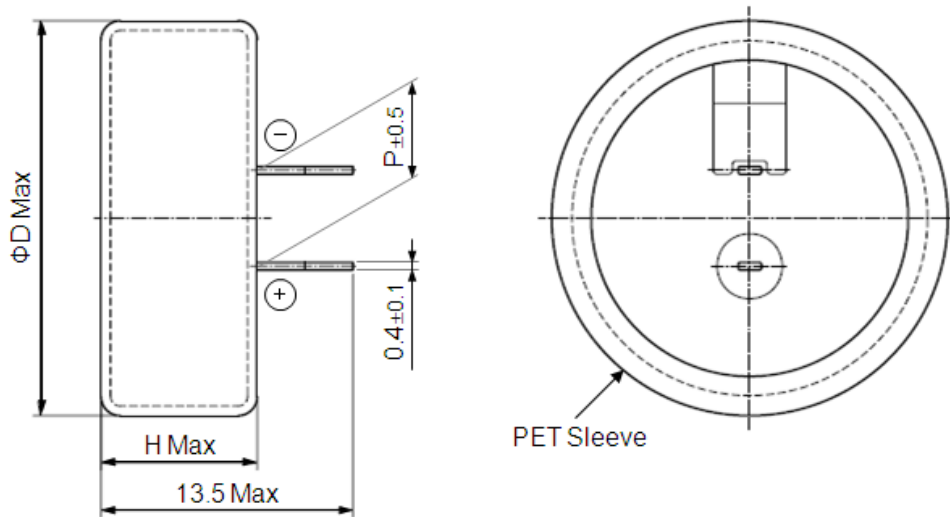

** There is no plating on the cut surface*

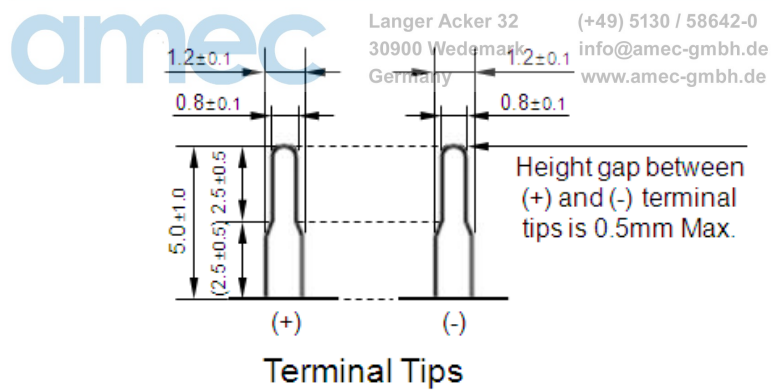

Part No.	Dimensions (mm)		
	ØD	H	P
DCLT3R6105CF	21.5	7.5	5.0
DCLT3R6155CF	21.5	7.5	5.0

6. Reliability Specifications

Item		Specification		Test Condition (JISC5102)													
Temperature Characteristics	Capacitance Change	Step 2	Within ± 30% of Initial Value	Measure electrical characteristics after exposing STARCAP Capacitor to each temperature atmosphere for one(1) hour <table border="1" style="margin-left: auto; margin-right: auto;"> <thead> <tr> <th>Step</th> <th>Temperature</th> </tr> </thead> <tbody> <tr> <td>1</td> <td>20±2°C</td> </tr> <tr> <td>2</td> <td>-25±2°C</td> </tr> <tr> <td>3</td> <td>20±2°C</td> </tr> <tr> <td>4</td> <td>85±2°C</td> </tr> <tr> <td>5</td> <td>20±2°C</td> </tr> </tbody> </table>		Step	Temperature	1	20±2°C	2	-25±2°C	3	20±2°C	4	85±2°C	5	20±2°C
	Step		Temperature														
	1	20±2°C															
	2	-25±2°C															
	3	20±2°C															
	4	85±2°C															
	5	20±2°C															
ESR	5Times or less than Initial Value																
Capacitance Change	Step 4	Within ± 30% of Initial Value															
ESR		4Times or less than Initial Value															
LC(30min.)		4Times or less than Initial Value															
Capacitance Change	Step 5	Within ± 10% of Initial Value															
ESR Change		Within ± 10% of Initial Value															
LC Change (30min.)		Within ± 10% of Initial Value															
Humidity Resistance	Capacitance Change	± 30% of Initial Value		Temp. : 40±2°C Humidity : 90 ~ 95%RH Time : 240±8 Hours No Voltage Applied													
	ESR	3Times or less than Spec. Value															
	LC(30min.)	2Times or less than Spec. Value															
	Appearance	No Marked Defect															
Self Discharge Characteristics	Voltage	More than 2.5Vdc	Charging Condition	Voltage : 3.6Vdc Current : 20mA Charge Time : 24 Hours													
			Self Discharge Condition	Duration : 24 Hours Temp. : Less than 25°C Humidity : Less than 70%RH													
Vibration Resistance	Capacitance	Spec. Value		Amplitude : 1.5mm Frequency : 10 ~ 55Hz Direction : X, Y, Z 3 Directions Test Time : 6 Hours													
	ESR	Spec. Value															
	LC(30min.)	Spec. Value															
	Appearance	No Marked Defect															
Terminal Strength	Appearance	Terminals shall not be separated		Load 1kg , 10±1 Sec.													
Terminal Bend Strength				Load 1kg , Angle 90° , 1Cycle													
Endurance	Capacitance Change	Within ± 30% of Initial Value		Temp. : 85±2°C Test Time : 1,000(+24,-0) Hours Applied Voltage : 3.6Vdc													
	ESR	4Times or less than Initial Value															
	LC(30min.)	Spec. Value															
	Appearance	No Marked Defect															
Cycle Characteristics	Capacitance Change	Within ± 30% of Initial Value		Temp. : 25±2°C Cycle No. : 10,000 Charge Voltage : 3.6Vdc Resistance : 100Ω, Time : 9min. Discharge Resistance:100Ω, Time:1min.													
	ESR	4Times or less than Initial Value															
	LC(30min.)	Spec. Value															
	Appearance	No Marked Defect															

7. Packing Specifications

Part No.	Quantity (PCS)			Size (W × L × H mm)		Type
	Tray	Inner Box	Outer Box	Inner Box	Outer Box	
DCLT3R6105(V,H,C)	50	350	700	295×230×140	485×305×150	Tray
DCLT3R6155(V,H,C)	50	350	700	295×230×140	485×305×150	Tray

8. Labeling Standards

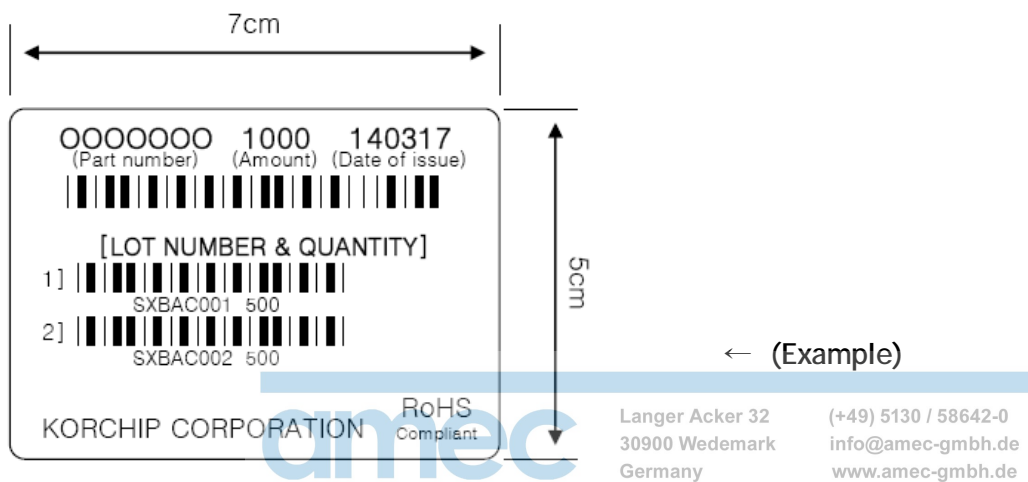

Lot No. System

Ex.) S Z B A C 002
 ① ② ③ ④ ⑤ ⑥

- ① Product Code : S (STARCAP)
- ② Production Year Code : Y (2014), Z (2015), A (2016)...
- ③ Factory Identification Code : B (Factory 2)
- ④ Production Month Code : A (Jan.), B (Feb.), ... , J (Oct.), K (Nov.), L (Dec.)
- ⑤ Production Date Code : 1 (1st), 2 (2nd), ... , 9 (9th), A (10th), B (11th), C (12th) ...
 Q (26th), R (27th), S (28th), ... , V (31th)
- ⑥ Lot Issuing Serial Code : 001 (First lot of a specific day), 002 (Second lot of a specific day), 003 (Third lot of a specific day)...

9. Measuring Method of Characteristics

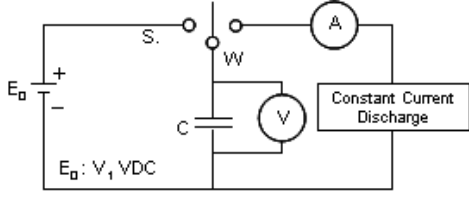
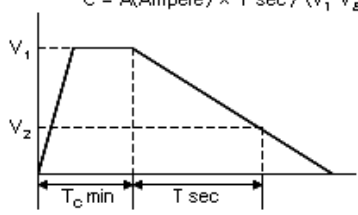
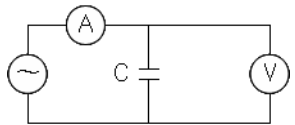
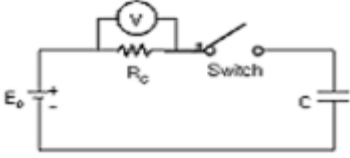
<p>Capacitance</p>	<ol style="list-style-type: none"> 1) Charge the STARCAP with constant current $50 \pm 0.1 \text{ mA}$ to the voltage of $V_1 (=2.8 \text{ V})$ for 1 hour. 2) Discharge the STARCAP with constant current (A) max. $3 \pm 0.1 \text{ mA}$ to the voltage of $V_2 (=1.4 \text{ V})$ while measure the discharge time (T). 3) Calculate capacitance using the following formula.  $C = A(\text{Ampere}) \times T \text{ sec} / (V_1 - V_2) \text{ V [F]}$ 
<p>Equivalent Series Resistance (ESR @1kHz)</p>	<ul style="list-style-type: none"> • Measure ESR by the LCR meter. (Frequency:1kHz, Bias Voltage : $0^{+0.05} \text{ V}$) • Calculate ESR using the following formula.  $ESR[\Omega] = V / i$ <p> $R[\Omega] = V[V] / I[A]$ * $i[\text{mA}] = I[A] \times 10^{-3}$ R : Internal resistance(ESR) [Ω] V : Measured voltage between terminals [V] i : Current 1mA(A.C.) </p>
<p>Leakage Current</p>	<ol style="list-style-type: none"> 1) Apply $3.6 \pm 0.1 \text{ V}$ to the STARCAP. (E_0) 2) Measure V_R after $30 \pm 0.5 \text{ min}$. 3) Calculate current using the following formula.  $LC = (V_R / R_C) \times 10^3 \text{ [mA]}$ <p> V_R = Measured value $R_C = 100 \Omega$ (0.47F) 1000Ω (1F, 1.5F) </p>
<p>☞ The STARCAP should be shorted before each measurement as follows ; Capacitance : 60 min. , ESR : 15 min. , LC : 15 min.</p>	

10. Mounting

When you solder STARCAP to a printed circuit board, excessive thermal stress could cause the STARCAP's electrical characteristics to deteriorate, compromise the integrity of the seal or cause the electrolyte to leak due to increased internal pressure.

① Recommended condition of flow soldering

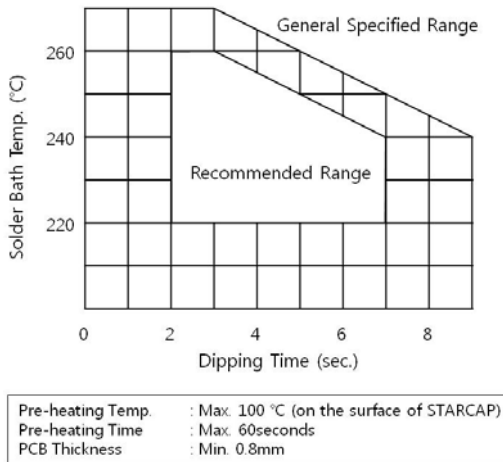

② Recommended condition of manual soldering

- Soldering Tip Temp. : 350°C or less
- Soldering Time : 3 sec. or less
- Times : Three times or less at intervals of 9 sec. or more
- ※ Do not touch the metal case of STARCAP with a soldering iron.

Langer Acker 32 (+49) 5130 / 58642-0
 30900 Wedemark info@amec-gmbh.de
 Germany www.amec-gmbh.de

③ It is not allowed to go through reflow (IR, Atmosphere heating methods etc.) process.

④ The terminals are plated for good solderability. Rasping terminals may damage the plating layer and degrade the solderability.
 Do not apply a large force to the terminals. Otherwise, they may break or come off or the STARCAP characteristics may be deteriorated.

11. Cautions for Use

Please be careful for following points when you use STARCAP.

1) Do not apply more than rated voltage.

If you apply more than rated voltage, STARCAP's electrolyte will be decomposed and its ESR increase. At the worst, it may be broken.

2) Do not use STARCAP for ripple absorption.

3) Polarity

Please mount it in accordance with its polarity.

4) Operating temperature and life

Generally, STARCAP has a lower leakage current, longer back-up time and longer life in the low temperature i.e. the room temperature. But it has a higher leakage current, shorter back-up time and shorter life in the high temperature.

Please design to keep STARCAP away from calorific parts.

amec From April 2011 Tel: +49 5130 / 58642-0
 30900 Wedemark info@amec-gmbh.de
 Germany www.amec-gmbh.de

5) Cleaning

Some detergent or high temperature drying causes deterioration of STARCAP. If you wash STARCAP, Consult us.

6) Following figure shows the general back-up circuit.

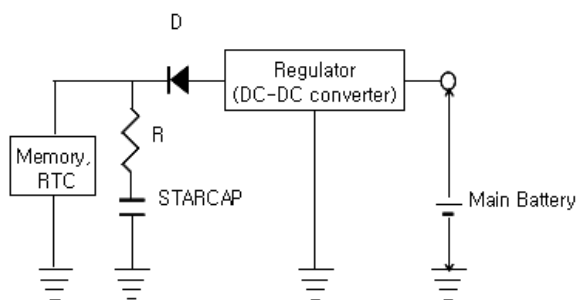

D : Diode to prevent the reverse current
 R : Resistor to control the charging current

7) Short-circuit STARCAP

Do not short-circuit between terminals of STARCAP without resistor.

8) Storage

In long term storage, please store STARCAP in following condition;

- ① TEMP. : 15 ~ 35 °C
- ② HUMIDITY : 45 ~ 75 %RH
- ③ Non-dust, non-acidic and/or non-alkaline atmosphere
- ④ Avoid direct sun light, strong magnetic field

Storage period limit is one(1) year when a STARCAP is stored in the above condition. Storage in improper condition may cause some damage on terminal surface or on outer tube of STARCAP.

9) Do not disassemble STARCAP. It contains electrolyte.

10) Series connection of STARCAP

Over-rated voltage may be applied to a single STARCAP in series connection due to the deviation of capacitance and ESR of each STARCAP. Please inform us if you are using STARCAP in series connection and please design so as not to apply over-rated voltage to each STARCAP, and use STARCAPs from same lot.



Langer Acker 32
30900 Wedemark
Germany

(+49) 5130 / 58642-0
info@amec-gmbh.de
www.amec-gmbh.de

11) The tips of STARCAP terminals are very sharp. Please handle with care.

12. Environmental Management

All STARCAP products are RoHS compliant, Halogen Free and environment friendly.

Series	RoHS directive (Pb, Cr+6, Hg, Cd, PBB,PBDE)	ELV directive (Pb, Cr+6, Hg, Cd)	PVC	Halogen Flame Retardant Free (Cl, Br)	etc.
DCLT	N.D.	N.D.	N.D.	N.D.	

* N.D. : Not detected



Langer Acker 32
30900 Wedemark
Germany

(+49) 5130 / 58642-0
info@amec-gmbh.de
www.amec-gmbh.de