

# Quick Start Guide

## FINDER

SZ05-EN-A02

### WARNING

- 
1. Hot! Avoid touching the heating nozzle in operation.
  2. Moving parts in printer may cause injury. Do not wear gloves or other sources of entanglement in operation.
- 

### USER GUIDE

---

The User Guide is in the USB stick.

---

# Kit Contents

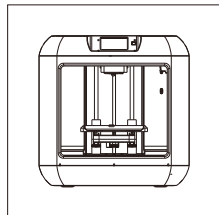

3D Printer

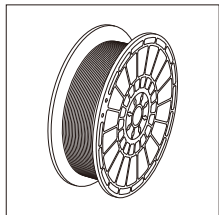

Filament Spool

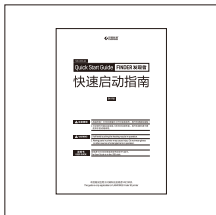

Quick Start Guide



After-sales Service Card

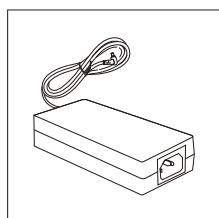

Power Adapter

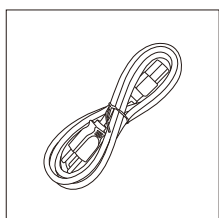

Power Cable

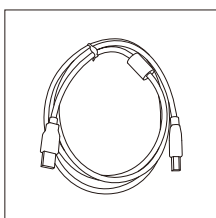

USB Cable

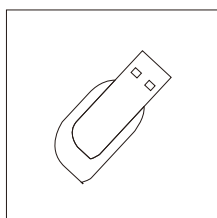

USB Stick

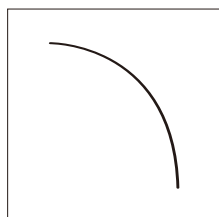

Filament Guide Tube

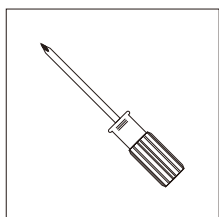

Screwdriver

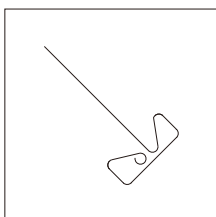

Unclogging Pin Tool

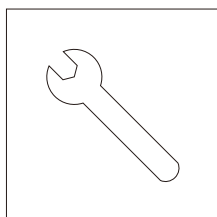

Wrench

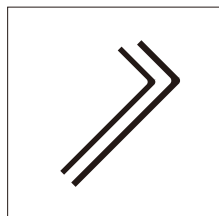

Allen Wrench

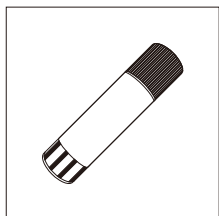

Solid Glue

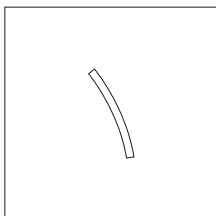

PTFE Tube

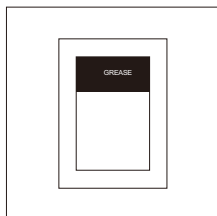

Grease

## Getting to Know Your Finder

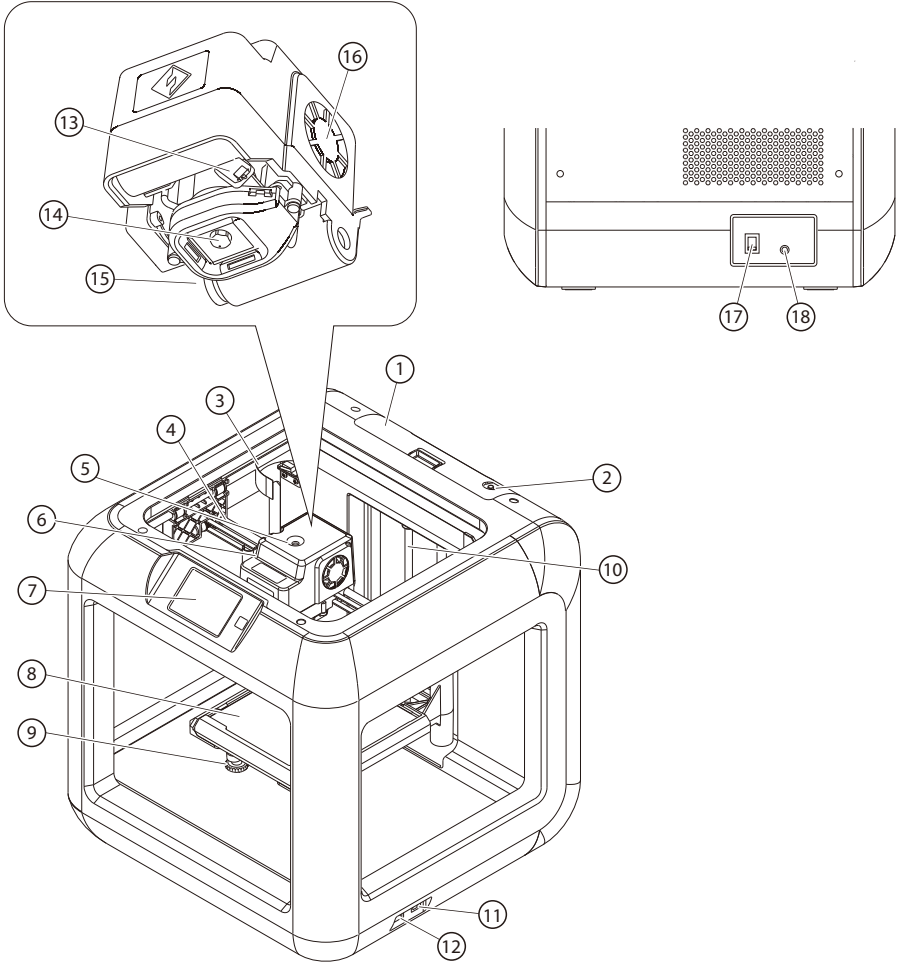

- |                       |                      |                     |                     |
|-----------------------|----------------------|---------------------|---------------------|
| 1. Filament Cartridge | 2. Filament Outlet   | 3. Y-Axis Guide Rod | 4. X-Axis Guide Rod |
| 5. Filament Inlet     | 6. Spring Presser    | 7. Touch Screen     | 8. Build Plate      |
| 9. Leveling Knob      | 10. Z-Axis Guide Rod | 11. USB Cable Input | 12. USB Stick Input |
| 13. Servo             | 14. Nozzle           | 15. Turbopan Baffle | 16. Turbopan        |
| 17. Power Switch      | 18. Power Input      |                     |                     |

## Unpacking



1. Open the box, grasp the two handles and then lift your Finder out of the box.



2. Remove the side protective foam sheets, you will see the Finder in a transparent bag.



3. Remove the tape and then remove the bag.



5. The foam sheet on top of the printer should contain: Quick Start Guide, After-sales Service Card, USB stick, Allen wrenches, screwdriver, unclogging pin tool, wrench, PTFE tube, power cable and grease.

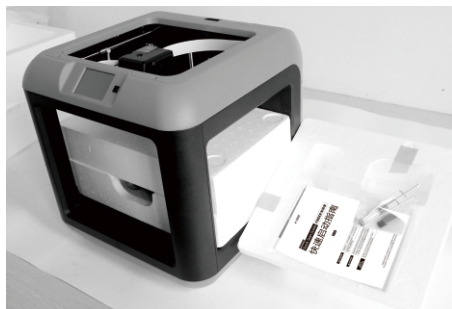

5. Remove the top foam sheet.

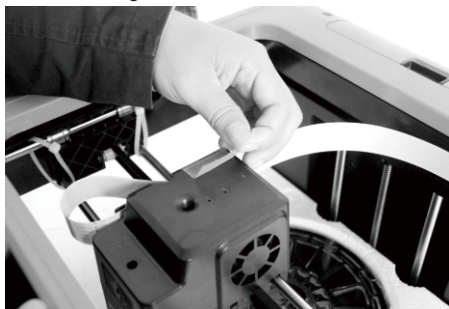

6. Discard the blue tape that holds the flat cable in place. Be careful with the flat cable.



7. Use scissors to cut the four buckles that hold the rods in place.



8. Take the protective foam for filament out of the Finder. You will see a spool of PLA filament inside.



9. Lift the build plate up with care.



10. Remove the protective foam underneath. It should contain: power adaoter, USB cable, solid glue, filament guide tube.



11. Congratulations! You've unpacked your printer. Please keep the kit and packing for future use.

## Hardware Assembly

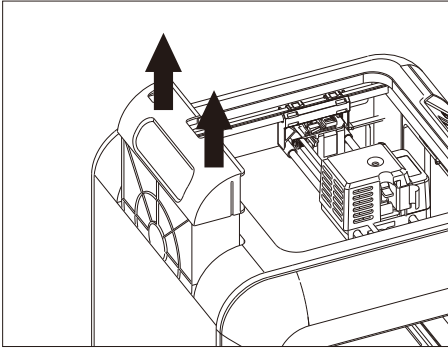

1. Take out the filament cartridge in the rear of Finder, where you will place the filament spool.

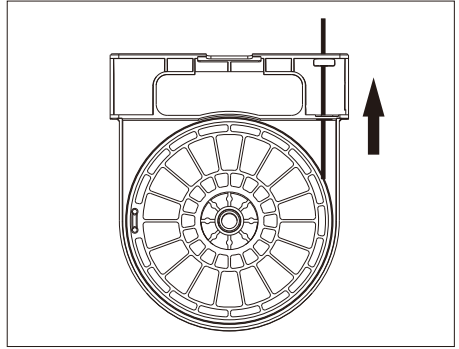

2. Insert the filament into the guide tube and thread the guide tube through the filament outlet. Place the spool of filament in the cartridge.

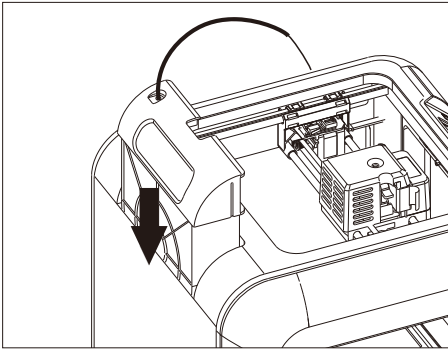

3. Put the filament cartridge back to the Finder.

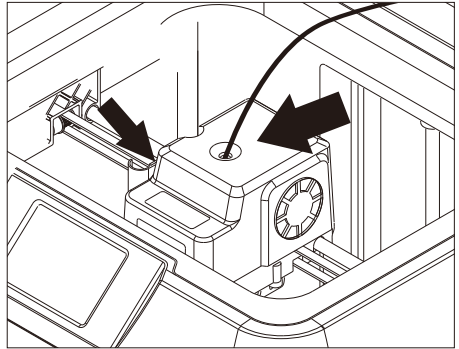

4. Press the spring presser, and insert the filament into the filament intake. Then release the spring presser.

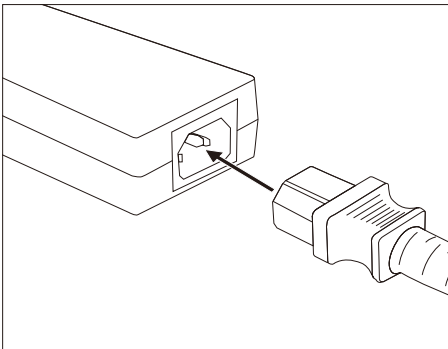

5. Connect power adapter with the power cable and then insert the power supply into the power input on the back of the finder. Turn on the power switch and press the touch screen button to turn on the printer.

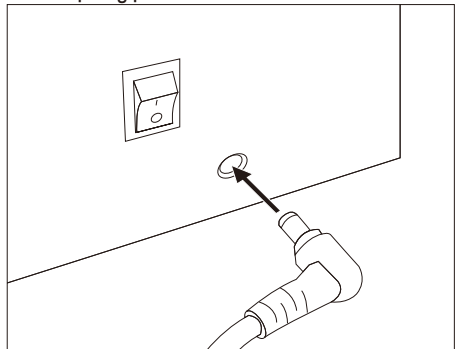

# Leveling Build Platform

## How to change language

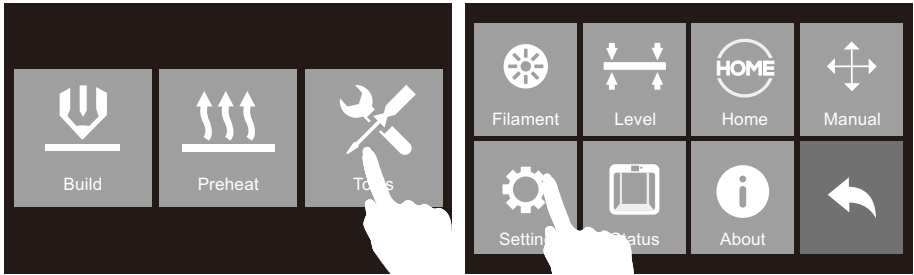

## Start to Leveling Build Platform

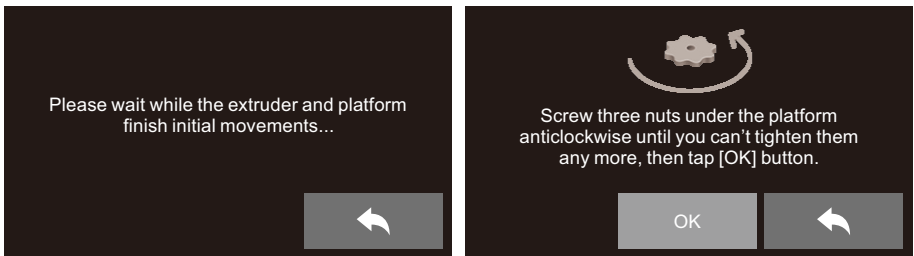

1. Tap [Tools] - [Level] on your Finder touch screen. Please wait while the extruder and platform finish initial movements. Screw three knobs under the platform anticlockwise until you can't tighten them any more, then tap [OK] button.

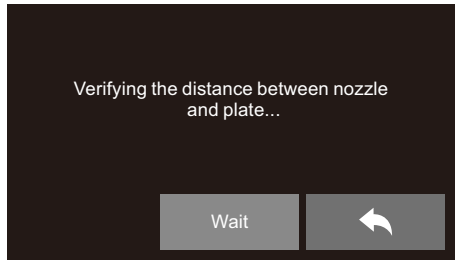

2. Tap [Yes] if you can't tighten all the nuts any more, or tap [No] to continue tightening. After selecting [Yes], the extruder will move towards the first point and the plate will move up and down to verify the distance between nozzle and plate.

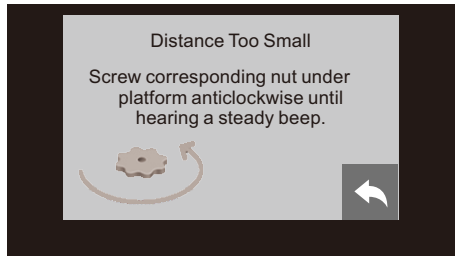
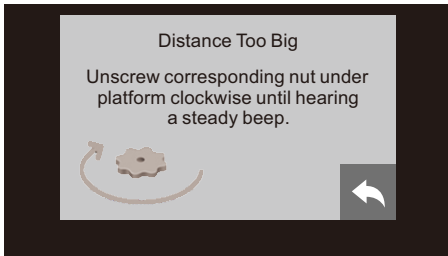

3. If the distance between the nozzle and plate is too large, rotate the knob underneath the platform clockwise until you hear a steady beep. If the distance is too small, rotate the knob anticlockwise until you hear a steady beep.

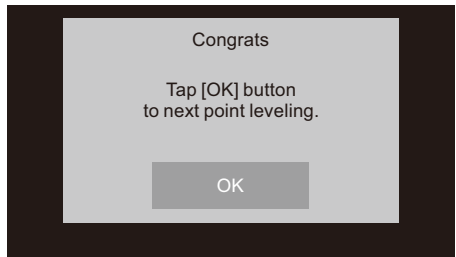
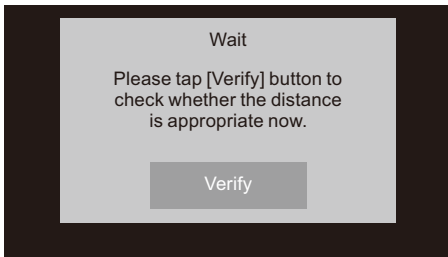

4. Then tap the [Verify] button to check whether the distance is appropriate this time. If the distance is appropriate now, tap [OK] to the second leveling point. If still not, please follow the prompts to adjust again till you see [OK] button.

Repeat steps 3 and 4 to level the second and third points. Then tap [Finish] to exit.



## Loading / Changing Filament

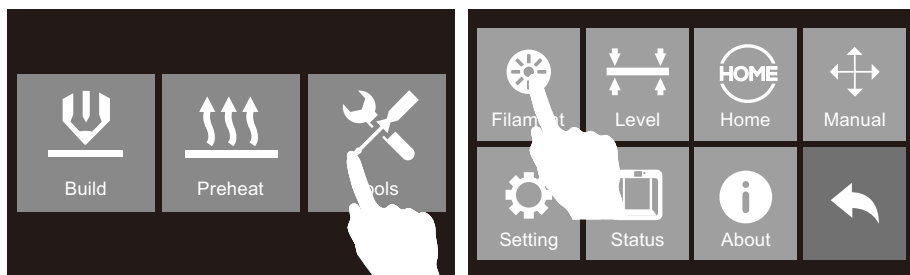

1. Tap [Tools] and then tap [Filament] and [Load] to load filament.

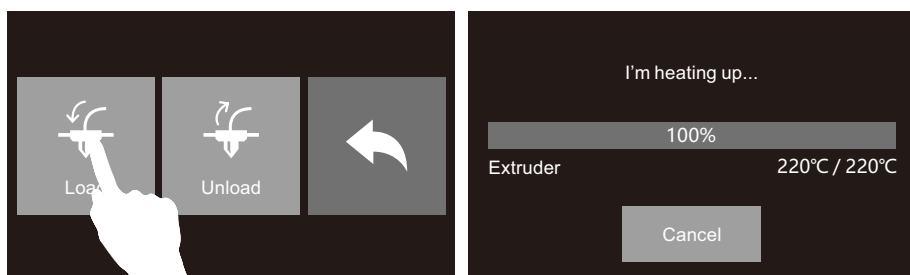

2. The extruder will automatically heat up. Once heated, filament will be drawn through the extruder. Continue extruding until the extruder provides a steady flow of filament.

### Changing Filament

Do not pull out the filament with force as it will damage the gears. If the melted filament has cooled down in the extruder, please follow the steps below.

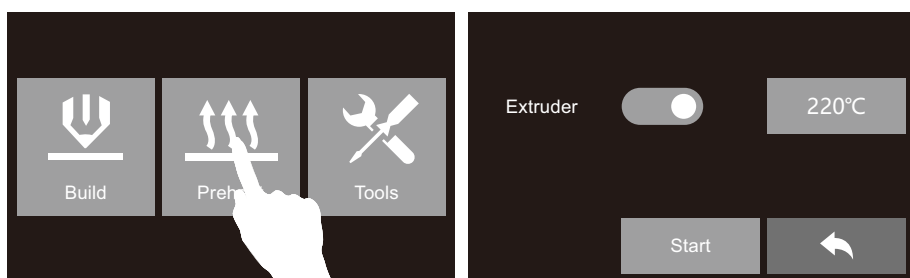

1. Tap [Preheat]--[Start] to heat up the extruder.
2. Once preheated, hold down the spring presser and pull out the filament.
3. Tap the return arrow, then insert the new filament into the filament intake. Select [Tools]-[Filament]-[Load]. The filament will be drawn through the extruder once heated. Wait for the extruder to provide a steady flow of filament.

## First Print

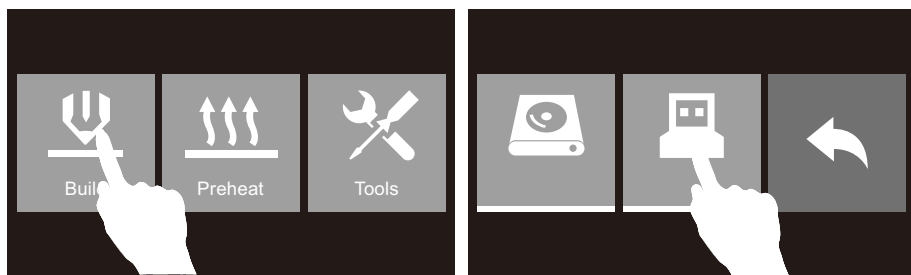

1. Please insert the USB stick into Finder. In the print interface, tap [Build]-[USB Stick].



2. Turn to the next page, tap [Test files].

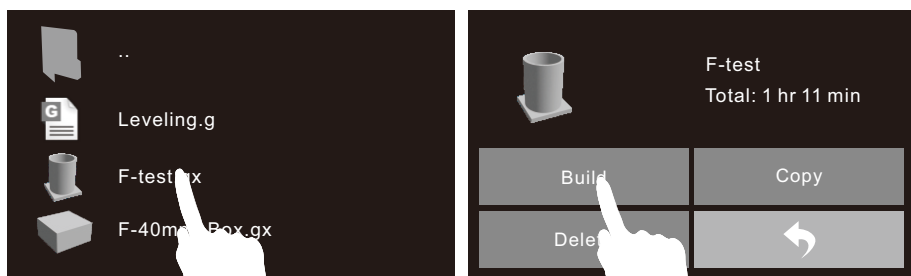

3. Tap [F-test file]-[Build].

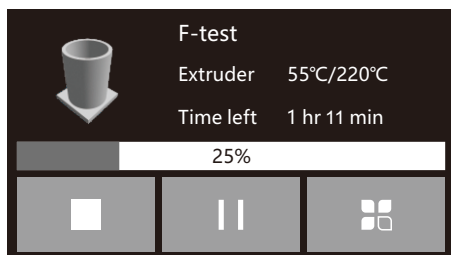

4. Once heated, the printer will start printing automatically.



You**Tube**

Scan QR to Get More  
After-Sales Support



浙江闪铸三维科技有限公司  
FLASHFORGE CORPORATION

---

After-Sales Service: [support@ff3dp.com](mailto:support@ff3dp.com)

---

Amazon.com orders only: [597891915@qq.com](mailto:597891915@qq.com)

---

Tel: +86 579 82273989 Web: [www.flashforge.com](http://www.flashforge.com) Add: 2/F, No.518, Xianyuan Road, Jinhua, Zhejiang, China