

1. Scope:

This specification for approval relates to Cement Fixed Resistors

2. Type designation:

The type designation shall be in the following form:

(Ex.)	<u>PRW</u>	<u>5W</u>	<u>J</u>	<u>1.2Ω</u>
	Type	Power Rating	Resistance Tolerance	Nominal Resistance

All part numbers in the coding below start with "TC-" and end with "203"

3. Ratings:

Ratings shall be shown in the table 1. Table 1

Type	PRW
Rated Power	5W at 70°C
Rated Ambient Temp.	70 °C
Operating Temp. Range	-55°C --- +155°C
Resistance Tolerance	± 5%
Wire-wound Resistance range	0.1Ω ~ 47Ω

3.1 Power rating:

Resistors shall have a power rating based on continuous full load operation at an ambient temperature of 70 °C

3.2 Voltage rating:

Resistors shall have a rated direct-current (DC) continuous working voltage or an approximate sine-wave root-mean-square (RMS) alternating-current (AC) continuous working voltage at commercial line frequency and waveform corresponding to the power rating , as determined from the following formula:

$$RCWV = \sqrt{P \times R}$$

Were : RCWV = Rated DC or RMS AC continuous working voltage at commercial-line frequency and waveform (volt)

P = Power Rating (watt)

R = Nominal Resistance (ohm)

Cement Fixed Resistors

Heat Rise Chart

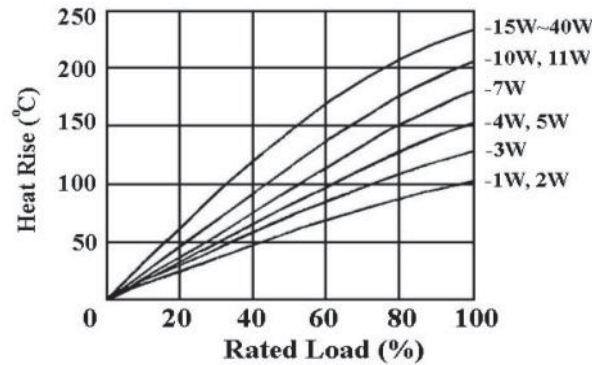

Derating Curve

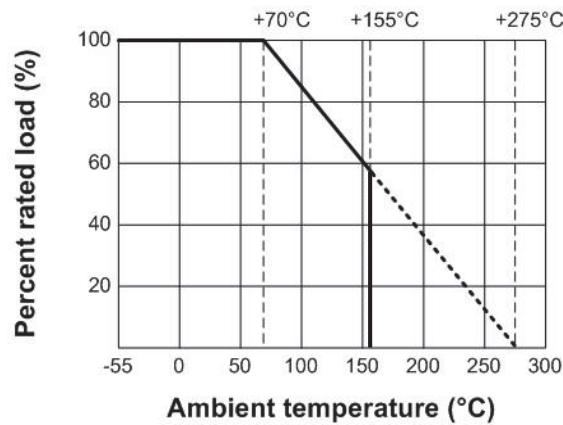

4. Construction:

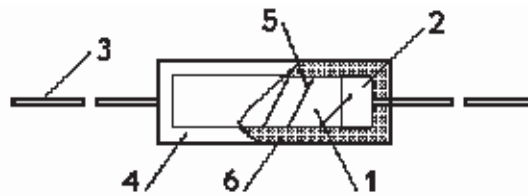

Cement: Wire wound type

Confirmation List of Material

No.	Subpart Name	Material	Material Generic Name	Remark
1	Body	Rod Type Ceramics	Al ₂ O ₃ , SiO ₂	
2	End Cap	Tin plated iron surface	Tin : 5%, Iron : 95%	
3	Lead	Annealed copper wire	Tin-Plated Copper wire	
4	Ceramic Case	Ceramic	Al ₂ O ₃ , SiO ₂	
5	Resistance wire	Cu-Ni Alloy / Ni-Cr Alloy	Cu-Ni Alloy / Ni-Cr Alloy	
6	Filling Materials	Quartz mixed sand	SiO ₂	

Cement Fixed Resistors		
5. Characteristic :		
Characteristics	Limits	Test Methods (JIS C 5201-1)
Dielectric withstanding voltage	No evidence of flashover, mechanical damage, arcing or insulation break down	Resistors shall be clamped in the trough of a 90° metallic V-block and shall be tested at AC potential respectively for 60 +10/ -0 secs. (Sub-clause 4.7)
Temperature coefficient	<math> <20\Omega: \pm 400 \text{ PPM}/^\circ\text{C} \text{ Max.}</math> $\geq 20\Omega: \pm 350 \text{ PPM}/^\circ\text{C} \text{ Max.}$	Natural resistance change per temp. degree centigrade. $\frac{R_2 - R_1}{R_1(t_2 - t_1)} \times 10^6 \text{ (PPM}/^\circ\text{C)}</math>R1: Resistance value at room temperature (t1)R2: Resistance value at room temp. plus 100 °C (t2)(Sub-clause 4.8)$
Short time overload	Resistance change rate is $\pm (5\% + 0.05 \Omega) \text{ Max.}$ with no evidence of mechanical damage	Permanent resistance change after the application of a potential of 2.5 times RCWV for 5 seconds (Sub-clause 4.13)

Cement Fixed Resistors		
5. Characteristic :		
Characteristics	Limits	Test Methods (JIS C 5201-1)
Terminal strength	No evidence of mechanical damage	<p>Direct load : Resistance to a 2.5 kgs direct load for 10 secs. in the direction of the longitudinal axis of the terminal leads</p> <p>Twist test : Terminal leads shall be bent through 90 ° at a point of about 6mm from the body of the resistor and shall be rotated through 360° about the original axis of the bent terminal in alternating direction for a total of 3 rotations (Sub-clause 4.16)</p>
Solderability	95 % coverage Min.	<p>The area covered with a new , smooth clean , shiny and continuous surface free from concentrated pinholes.</p> <p>Test temp. of solder : 245°C ± 5°C Dwell time in solder : 2 to 3 secs. (Sub-clause 4.17)</p>
Soldering temp. reference	Electrical characteristics shall be satisfied. Without distinct deformation in appearance. (95 % coverage Min.)	<p>The leads immersed into solder bath to 3.2 to 4.8 mm. from the body. Permanent resistance change shall be checked.</p> <p><u>Wave soldering condition: (2 cycles Max.)</u> Pre-heat : 100 ~ 120 °C, 30 ± 5 sec. Suggestion solder temp.: 235 ~ 255 °C, 10 sec. (Max.) Peak temp.: 260 °C</p> <p><u>Hand soldering condition:</u> Hand Soldering bit temp. : 380 ± 10 °C Dwell time in solder : 3 +1/-0 sec.</p>

Cement Fixed Resistors																	
Characteristics	Limits	Test Methods (JIS C 5201-1)															
Resistance to soldering heat	Resistance change rate is $\pm (1\% + 0.05 \Omega)$ Max. with no evidence of mechanical damage	Permanent resistance change when leads immersed to 3.2 to 4.8 mm from the body in $350^\circ\text{C} \pm 10^\circ\text{C}$ solder for 3 ± 0.5 secs. (Sub-clause 4.18)															
Temperature cycling	Resistance change rate is $\pm (2\% + 0.05 \Omega)$ Max. with no evidence of mechanical damage	Resistance change after continuous 5 cycles for duty shown below:															
		<table border="1"> <thead> <tr> <th>Step</th> <th>Temperature</th> <th>Time</th> </tr> </thead> <tbody> <tr> <td>1</td> <td>$-55^\circ\text{C} \pm 3^\circ\text{C}$</td> <td>30 mins</td> </tr> <tr> <td>2</td> <td>Room temp.</td> <td>10~15 mins</td> </tr> <tr> <td>3</td> <td>$+155^\circ\text{C} \pm 2^\circ\text{C}$</td> <td>30 mins</td> </tr> <tr> <td>4</td> <td>Room temp.</td> <td>10~15 mins</td> </tr> </tbody> </table>	Step	Temperature	Time	1	$-55^\circ\text{C} \pm 3^\circ\text{C}$	30 mins	2	Room temp.	10~15 mins	3	$+155^\circ\text{C} \pm 2^\circ\text{C}$	30 mins	4	Room temp.	10~15 mins
		Step	Temperature	Time													
		1	$-55^\circ\text{C} \pm 3^\circ\text{C}$	30 mins													
		2	Room temp.	10~15 mins													
3	$+155^\circ\text{C} \pm 2^\circ\text{C}$	30 mins															
4	Room temp.	10~15 mins															
(Sub-clause 4.19)																	
Load life in humidity	Resistance value	$\Delta R/R$															
	Wire-wound	$\pm 5\%$															
	Resistance change after 1,000 hours operating at RCWV with duty cycle of (1.5 hours "on", 0.5 hour "off") in a humidity test chamber controlled at $40^\circ\text{C} \pm 2^\circ\text{C}$ and 90 to 95 % relative humidity (Sub-clause 4.24.2.1)																
Load life	Resistance value	$\Delta R/R$															
	Wire-wound	$\pm 5\%$															
	Permanent resistance change after 1,000 hours operating at RCWV with duty cycle of (1.5 hours "on", 0.5 hour "off") at $70^\circ\text{C} \pm 2^\circ\text{C}$ ambient (Sub-clause 4.25.1)																

Cement Fixed Resistors

6. Dimension :

Unit : mm

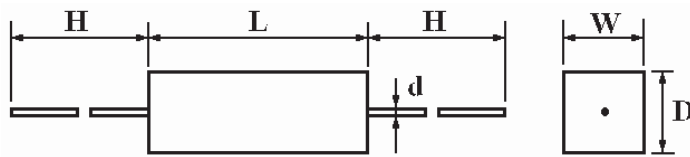

Type	Rating Wattage	W±1	D±1	L±1	d ± 0.05	H± 5
PRW	5W	10	9	22	0.75	35

7. Marking :

Ex.

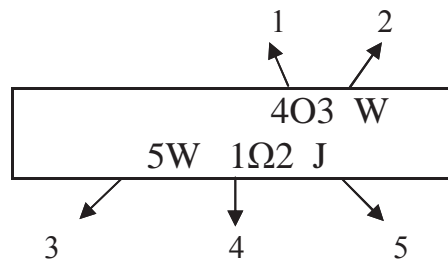

Code description and regulation

1. Date manufactured.

First code:	7 : The year 2007	1 : The year 2011
	8 : The year 2008	2 : The year 2012
	9 : The year 2009	3 : The year 2013
	0 : The year 2010	4 : The year 2014

Second code:	1 : January	5 : May	9 : September
	2 : February	6 : June	O : October
	3 : March	7 : July	N : November
	4 : April	8 : August	D : December

Third code:	1 : First 10 days of a month
	2 : Second 10 days of a month
	3 : Third 10 days of a month

2. W marking for Wire wound type

P marking for Power film type

3. Wattage rating.

4. Nominal resistance value.

J : ± 5 %

5. Resistance Tolerance.

K : ± 10 %

Color of marking: Black ink

Part Number System

Explanation of Part Number System (Cement Fixed Resistors)

All part numbers in the coding below start with "TC-" and end with "203"

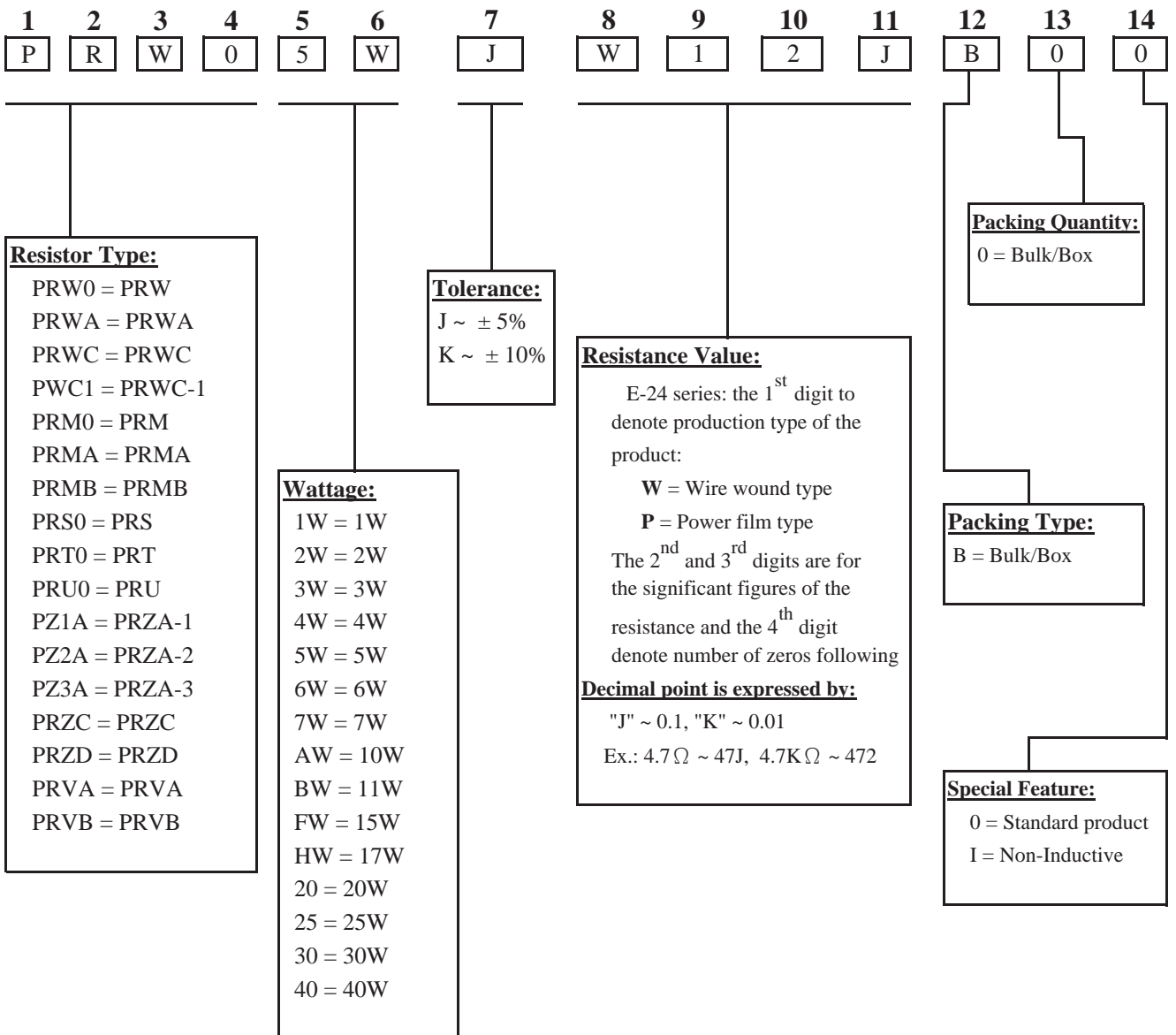

Sample: PRW 5W +/- 5% 1.2Ω B/B (Wire-wound type) → PRW05WJW12JB00

Cement Fixed Resistors

Environment Related Substance

This product complies to EU RoHS directive, EU PAHs directive, EU PFOS directive and Halogen free.

Ozone layer depleting substances.

Ozone depleting substances are not used in our manufacturing process of this product.

This product is not manufactured using Chloro fluorocarbons (CFCs), Hydrochlorofluorocarbons (HCFCs), Hydrobromofluorocarbons (HBFCs) or other ozone depleting substances in any phase of the manufacturing process.

Storage Condition

The performance of these products, including the solderability, is guaranteed for a year from the date of arrival at your company, provided that they remain packed as they were when delivered and stored at a temperature of $25^{\circ}\text{C} \pm 5^{\circ}\text{C}$ and a relative humidity of $60\%RH \pm 10\%RH$

Even within the above guarantee periods, do not store these products in the following conditions. Otherwise, their electrical performance and/or solderability may be deteriorated, and the packaging materials (e.g. taping materials) may be deformed or deteriorated, resulting in mounting failures.

1. In salty air or in air with a high concentration of corrosive gas, such as Cl_2 , H_2S , NH_3 , SO_2 , or NO_2
2. In direct sunlight

This is a publication by Conrad Electronic SE, Klaus-Conrad-Str. 1, D-92240 Hirschau (www.conrad.com).

All rights including translation reserved. Reproduction by any method, e.g. photocopy, microfilming, or the capture in electronic data processing systems require the prior written approval by the editor. Reprinting, also in part, is prohibited. This publication represents the technical status at the time of printing.

© Copyright 2017 by Conrad Electronic SE.