

Datasheet

Item no. 1586489

V1_0617_02_EN

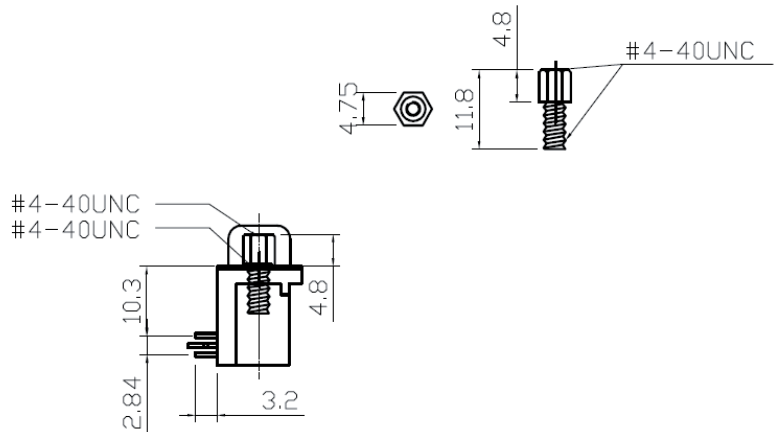
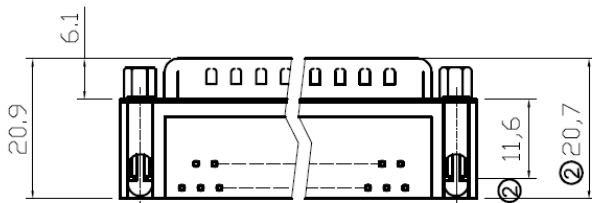
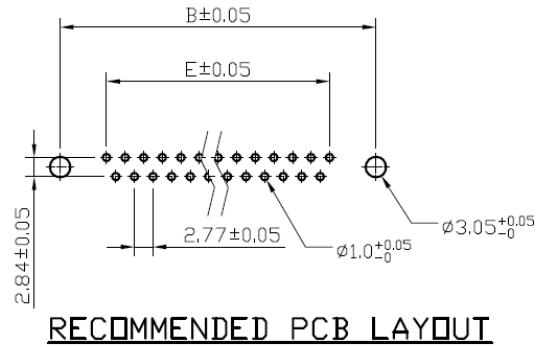
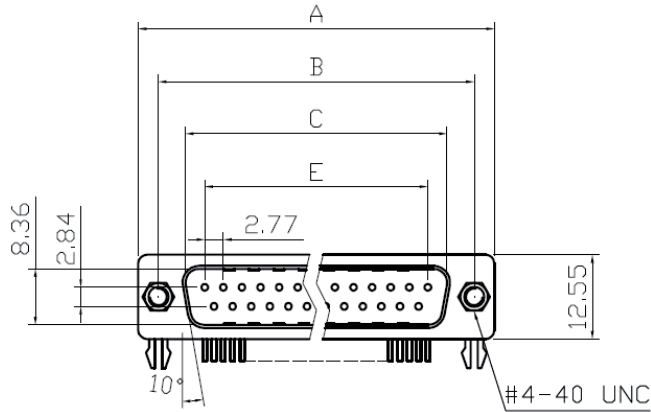

Material

Insulator : Glass-Filled thermoplastic PBT
UL94V-0 rated

Contact : Brass

Shell : Steel

Electrical

Contact Resistance : 20 milliohms
Max at 1 AMP DC.

Insulation Resistance : 1000
magohms at 500 VDC

Dielectric Withstanding Voltage :
1000 VAC/rms 60Hz for 1 minute

Current Rating : 5AMP

Volatge Rating : 250 VAC/rms 60Hz

① Solder temp for wave soldering : 220 ± 5°C, 3~5 s

A	B	C	E
30.81	24.99	16.92	11.08

RoHS compliant

Unit:mm



File No.: E198287