

Datasheet

Item no. 1586521

V1_0617_02_EN

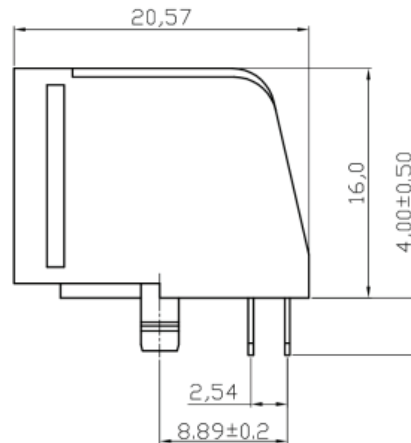
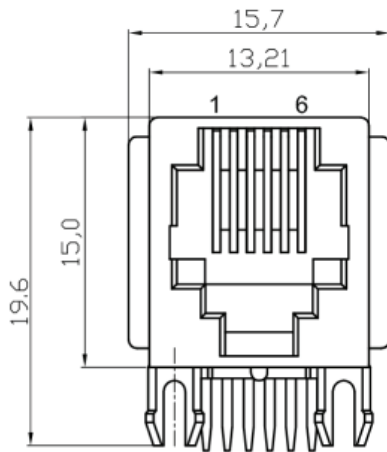

NOTES:

ELECTRICAL:

- 1. VOLTAGE RATING : 125 VAC MIN.
- 2. CURRENT RATING : 1.5 AMP MIN.
- 3. CONTACT RESISTANCE : 50 MILLIOHMS MAX.
- 4. INSULATION RESISTANCE : 1000 MEGOHMS MIN @ 500 VDC.
- 5. DIELECTRIC STRENGTH : 1000 VAC 60Hz, 1MIN.

MECHANICAL:

- 1. HOUSING MATERIAL : HIGH TEMP. UL94V-0.
- 2. CONTACT MATERIAL : PHOSPHOR BRONZE t=0.35mm.
- 3. PLATING : 6u" GOLD ON CONTACT AREA
100~200u" TIN ON SOLDER AREA
ALL OVER 30~50u" NICKEL.
- 4. OPERATING LIFE : 750 CYCLES MIN.
- 5. PCB RETENTION PRE-SOLDER : 1 LB MIN.
- 6. PCB RETENTION POST-SOLDER: 10 LBS MIN.

ENVIRONMENTAL:

- 1. STORAGE : -40°C TO +85°C.
- 2. OPERATION : -40°C TO +85°C.
- 3. WAVE SOLDER TEMPERATURE : 255°C TO 265°C 5~10 SECOND.

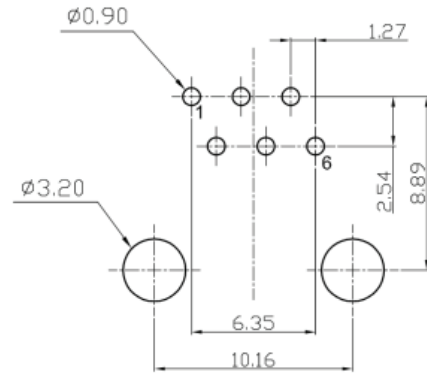

**PC Board Layout
Component Side Shown**

RoHS compliant

Unit: mm



File No.: E345352

