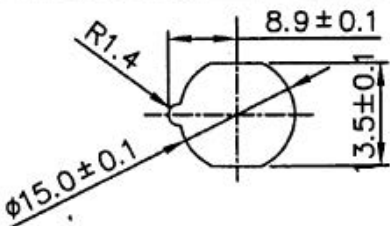

Fuse Holder, 15A250VAC Screw type

Rating	15A 250V AC	
Insulation R	DC 500V 100M ohm Min.	
Dielectric Strength	AC 1500V 1 minute	

Feature

Phenolic insulated.

Phenolic base and cover soldering resistant.

0.250 (6.3mm) quick terminal easilt installation.

20amp heavy duty rating at 250V AC.

Panel mounted by nut.

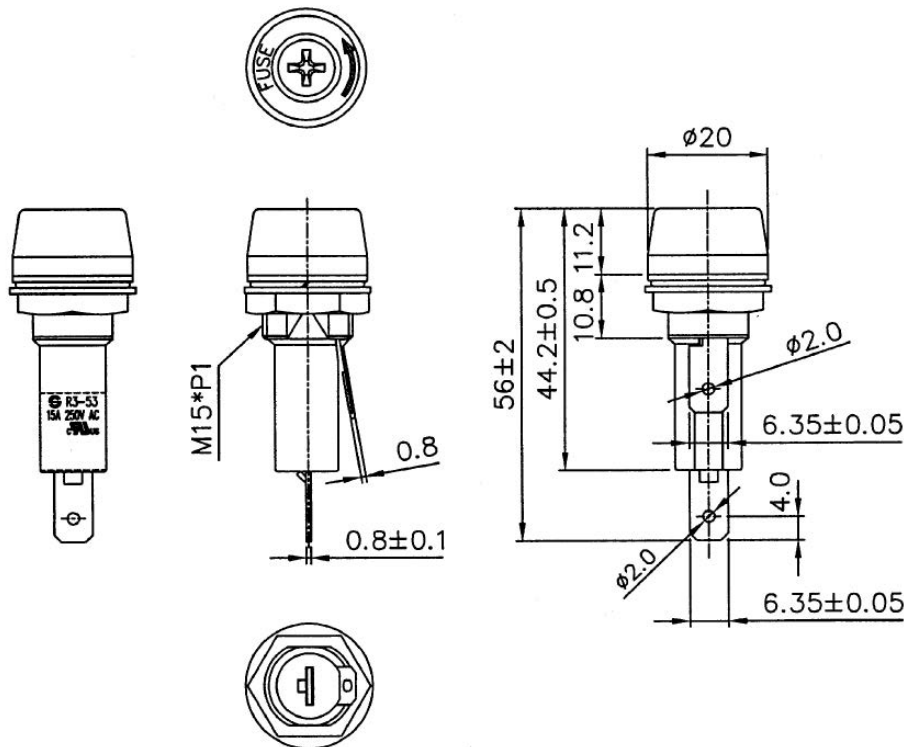

Unit: mm