

Item no.: BN 1592810

Data Sheet

Description : Releasable Ties

Item photo:

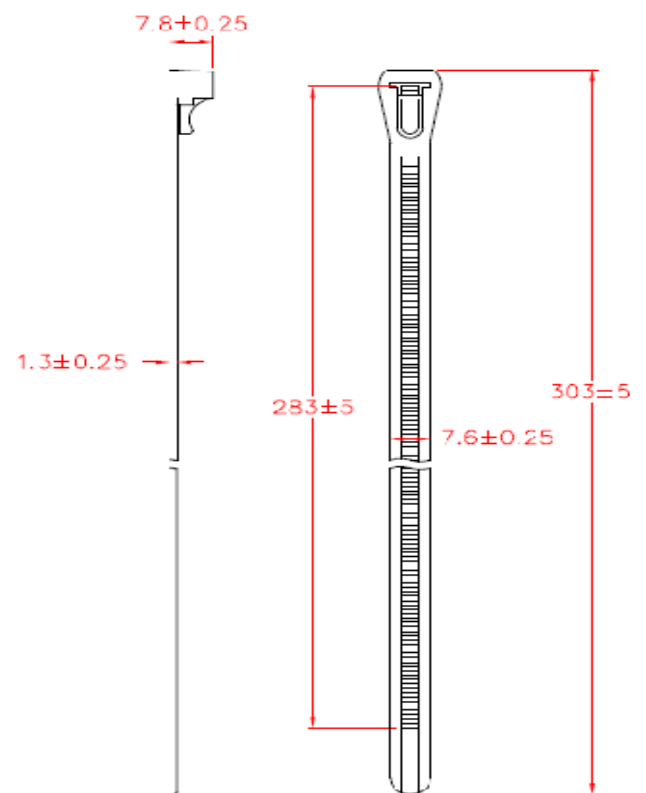

Unit: mm

Item No:	Length	Width	Max.Bundle Dia.	Tensile strength
HVC300BK	300	7.6	89	22kgs

Material : Nylon 66 , 94V-2

Color : Black