



TECHNOLOGY DATA SHEET & SPECIFICATIONS

MODEL: LB2-P200W3C-H3

Features

- Substrate: Aluminum Plate
- High intensity, Long life-span

Usage Notes:

- Surge will damage the LED
- When using LED, it must use a protective resistor in series with DC current about 750mA

Applications

- Automotive indicator light
- decoration and lighting
- electric torch etc

Device Selection Guide

LED Part No.	Chip		Lens Color
	Material	Emitted Color	
LB2-P200W3C-H3	InGaN	Warm White	Water clear

Electro-Optical Characteristics (Ta=25℃)

Parameter	Symbol	Min.	Max.	Unit	Test Condition
Luminous Intensity	FLux	140	180	lm	I _F =750mA
Viewing Angle	2θ1/2	110	120	Deg	I _F =750mA
Color Temperature	CT	2700	3500	K	I _F =750mA
Forward Voltage	V _F	3.5	4.0	V	I _F =750mA
Reverse Current	I _R	50	100	μA	V _R =5V

TECHNOLOGY DATA SHEET & SPECIFICATIONS

MODEL: LB2-P200W3C-H3

Package Dimensions

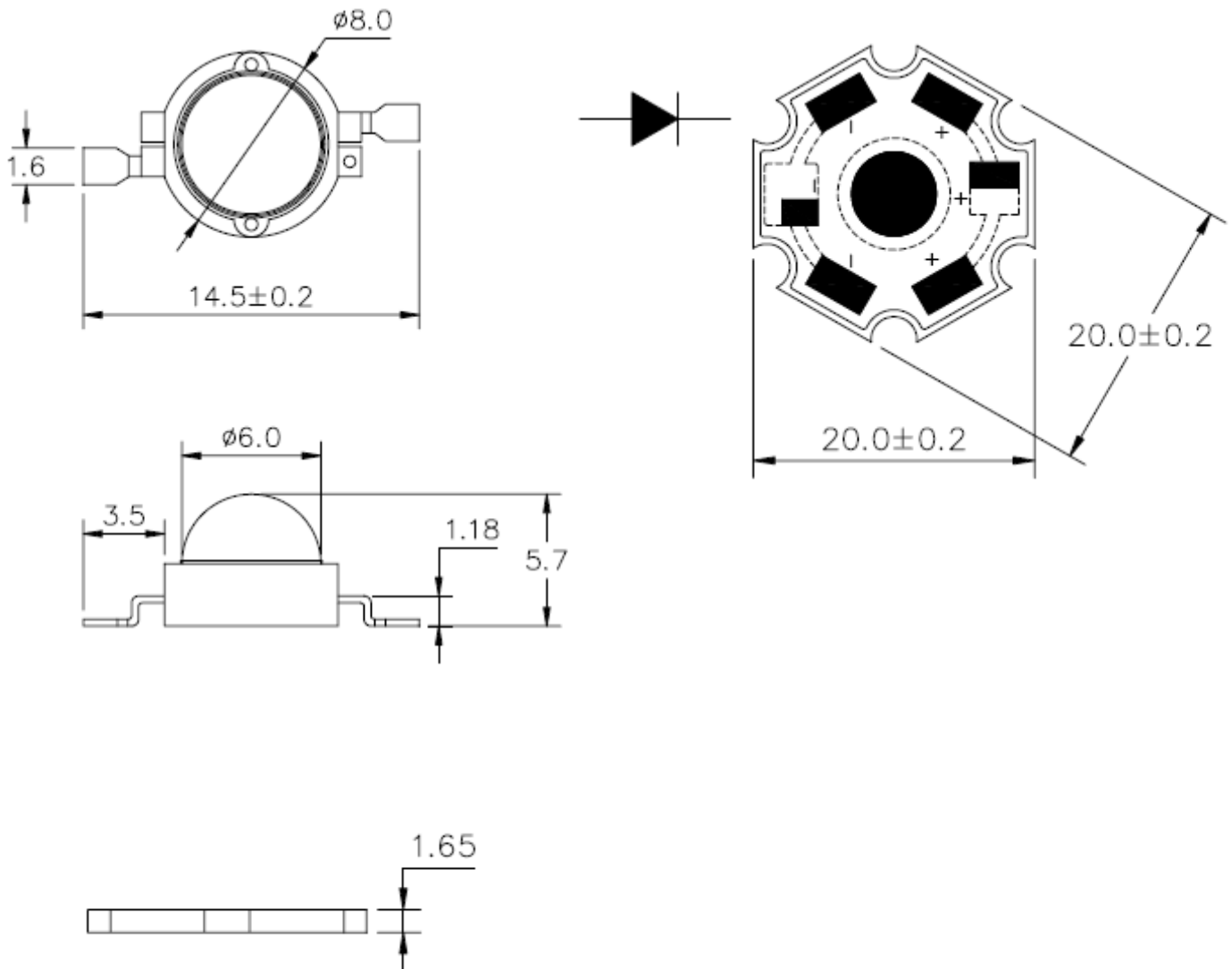

Notes:

- . Other dimensions are in millimeters, tolerance is 0.25mm except being specified
- . Product picture & dimensions are for reference only. Detailed information is in accordant with the final product.



TECHNOLOGY DATA SHEET & SPECIFICATIONS

MODEL: LB2-P200W3C-H3

APPLICATION NOTES

一. Heat dissipation

Because at present semiconductor light-emitting diode wafer technology restricting, LED Photoelectricity change efficiency remains to be improved, especially high-power LED , is higher because of it's power, have 60% the above electric energy to release to becoming a thermal energy (with the development of semiconductor technology approximately, the photoelectricity conversion efficiency meeting improves) gradually, be demanding a terminal when applying the high-power LED product the customer right now, need to do a good job in heat dissipation, to ensure that the high-power LED product works regularly.

My department submits suggestion about heat dissipation aspect according to product characteristic property and long range aging test data experience, For your reference only.

1 The cooling fin demands.

Exterior and material quality: If the finished product seals off a request no highly, may aluminum product or copper product cooling fin that convection , suggestion adopt to have fin movie happened directly with the external world air environment.

2 Effective heat dissipation superficial areas:

I attend to 50-60 squares recommending the effective heat dissipation of cooling fin superficial area sum \geq to 1 W high-power LED white light (colour is other basically identical) centimeter. 150 squares recommending the effective heat dissipation of cooling fin superficial area sum \geq to 3 W products centimeter, more, the high power looks at condition and test result increasing by , ensures that the cooling fin temperature does not exceed 60 to the full \sim C

3 Connection methods:

The high-power LED base board and the cooling fin ensure that two contact surfaces neat , get in touch with when linking up, please fine, for the union degree reinforcing two contact surfaces, (3.0 W/m.k , heat conduction silicon greases suggesting that the base board bottom or the cooling fin surface scribbles in LED applying a layer of heat conduction silicon grease heat conduction silicon grease heat conduction modulus \geq) require that Tu applies homogeneously , closes just the right amount again with screw pressure fixation.

二: Static electricity protects:

LED belongs to a semiconductor device , static electricity is face to face comparatively sensitive , especially with regard to white , green , blue, purple LED needs to do a good job in preventing static electricity from coming into being and removing static electricity

1. Electrostatic creation:

○Friction: But part for again , be OK to produce static electricity after the object in the daily life, any two being unlike material quality is contacted, produce electrostatic the most common method , be the electricity rubbing a life. The material insulation is the better , the easier to rub the life electricity. The object besides, being unlike matter any two kinds touches the queen parting for again , also can



TECHNOLOGY DATA SHEET & SPECIFICATIONS

MODEL: LB2-P200W3C-H3

produce static electricity.

②Response

Can flow in its surface liberty specifically for electric conduction material Er Yan , because of the electron , change , only be capable to do in whose surface creation electric charge , if in placing the person in one electric field since the isomorphism is repulsive , the opposite sex attracts each other , the positiveness and negativeness ion is therefore likely.

③Conduction

Can flow in its surface liberty specifically for electric conduction material Er Yan , because of the electron, if with electrified object meet] touch, with electric charge happened changing.

2. Static electricity damage to LED

① But because of the heat that moment electric field or electric current produces, make LED part be wounded, behavior is that leakage of electricity stream is prompt increase by , still can work, brightness is reduced (white light will may change colour) , life-span is derided.

②The insulating barrier destroying LED's because of the electric field or electric current, makes a component there be no the [law job (destroy completely) , shows for dead light.

3. Static electricity protects and removes measure

Needing to be ready for guard against and remove static electricity measure , have mainly to the employee that entire working procedure (giving birth to a child , testing , packing and so on) possessions and LED touch straightly:

①Workshop laying guards against the static electricity floor is ready for ground connection together.

②The working table is that the platform ground connection guarding against the static electricity working table , producing machine is fine

③The operator is penetrated guarding against static electricity being convinced, as well as guarding against the static electricity hand ring , glove or foot ring

④Wind machine , welding electric iron applying an ion are ready for ground connection measure

⑤Package is adopt to guard against static electricity material

三. Weld

Pay attention to the flatiron choosing the constant temperature time welding, please, the welding temperature is 260 ~C , the time that the flatiron and the LED pad once touch does not exceed 3 S (Pay attention to electric iron time welding definitely ask ground connection , operation personnel to be going to wear the static electricity hand ring or to blow an ion wind machine)

Four drive a circuit abiding by the diode volt-ampere characteristic property curve because of high-power LED , corresponding drive electric current drift is very big , easy to damage the light pearl if drive voltage floats, therefore, suggest that the customer uses more stable constant current to drive power source or IC, but not adopt a constant voltage to drive power source or IC.



TECHNOLOGY DATA SHEET & SPECIFICATIONS

MODEL: LB2-P200W3C-H3

Notes

1. Above specification may be changed without notice. Hyled will reserve authority on material change for above specification.
2. When using this product, please observe the absolute maximum ratings and the instructions for using outlined in these specification sheets. Hyled assumes no responsibility for any damage resulting from use of the product which does not comply with the absolute maximum ratings and the instructions included in these specification sheets.
3. These specification sheets include materials protected under copyright of Hyled corporation. Please don't reproduce or cause anyone to reproduce them without Hyled's consent.