



LMT78_0.5R Series

Wide input, non-isolated & regulated, single output, SMD package

Switching Regulator

- ⊕ Efficiency up to 96%
- ⊕ No need for heat sinks
- ⊕ 0.5AMP SMD package
- ⊕ Wide input voltage range (4,75V - 36V)
- ⊕ Adjustable output voltage
- ⊕ Remote ON/OFF control
- ⊕ Short circuit protection (SCP), thermal shutdown
- ⊕ Very low shutdown current
- ⊕ Super low ripple and noise
- ⊕ Meets IEC62368, UL62368, EN62368 standards (pending)

The LMT78_0.5R Series with high efficiency switching regulators is an ideally supply for space constrained mobile applications. There is no need for any heat sink, even if operated at + 85°C. The additional features include remote ON/OFF control and adjustable output voltage.

Super low ripple and noise of typically only 10mV and a shutdown input current of typically only 15uA.



Common specifications	
Cooling:	Free air convection
Short circuit protection mode:	Hiccup mode
Short circuit protection:	tinuous, automatic recovery
Operating temperature range:	-40°C ~ +85°C
Storage temperature range:	-55°C ~ +125°C
Lead temperature:	300°C MAX, 1.5mm from case for 10 sec
Operating case temperature:	100°C MAX
Reflow Soldering Temperature:	Peak temp. ≤ 245°C, maximum duration time ≤ 60s at 217°C. For actual application, please refer to IPC/JEDEC J-STD-020D.1
Storage humidity range:	< 95%
Case material:	Plastic [UL94-V0]
MTBF (MIL-HDBK-217F, +25°C):	> 2,000,000 hours
Package weight:	1.5g
Dimensions:	15.24 * 11.40 * 8.25mm

Input specifications						
Item	Test conditions	Min	Typ	Max	Units	
No load input current			0.2	1.5	mA	
Reverse polarity input	Forbidden					
Input filter	Capacitor					
Remote ON/OFF*	<ul style="list-style-type: none"> • Module switch on • Module switch off • Input current when switched off 		suspended or connected to TTL high level (3.2-8VDC) pin connected to GND or low level (0-0.8VDC)	30	100	μA

* The voltage of Remote ON/OFF pin is relative to pin GND.

Output specifications						
Item	Test conditions	Min	Typ	Max	Units	
Output voltage accuracy	Input voltage range at full load • 1.5/1.8/2.5/3.3VDC • Others		±2 ±2	±4 ±3	% %	
Line regulation	Input voltage range at full load		±0.2	±0.4	%	
Load regulation	Nominal input, 10% to 100% load • 1.5/1.8/2.5VDC • Others			±1 ±0.6	% %	
Ripple + Noise*	20MHz bandwidth 1.5/1.8/2.5/3.3VDC • 20% - 100% load • < 20% load Others • 10% - 100% load • < 10% load		20 20	50 100	mVp-p mVp-p	
Temperature coefficient	- 40°C to + 85°C ambient			±0.03	%/°C	
Transient response deviation	Nominal input voltage, 25% load step change		50	200	mV	
Transient recovery time	Nominal input voltage, 25% load step change		0.2	1	ms	
Vadj	input voltage range		±10		%Vo	
Switching frequency	Full load, nominal input voltage • LMT78_1.5-0.5R • Others		370 700		KHz KHz	

* Ripple and noise tested with "parallel cable" method, please refer to DC-DC converter Application Notes for specific operation methods.

Example:
LMT78_05-0.5R
LM = Series; T = SMT case; yy = 5Vout; pp = 0.5A; R = Revised

Note:

1. All specifications measured at Ta = 25°C, humidity <75%, nominal input voltage and rated output load unless otherwise specified.
2. In this datasheet, all the test methods of indications are based on corporate standards.

LMT78_0.5R Series

Wide input, non-isolated & regulated, single output, SMD package

EMC specifications

EMI	CE	CISPR32/EN55032	CLASS B	(see EMC recommended circuit, ②)
EMI	RE	CISPR32/EN55032	CLASS B	(see EMC recommended circuit, ②)
EMS	ESD	IEC/EN61000-4-2	Contact ±4KV	perf. Criteria B
EMS	RS	IEC/EN61000-4-3	10V/m	perf. Criteria A
EMS	EFT	IEC/EN61000-4-4	±2KV	perf. Criteria B (see EMC recommended circuit, ①)
EMS	Surge	IEC/EN61000-4-5	line to line ±1KV	perf. Criteria B (see EMC recommended circuit, ①)
EMS	CS	IEC/EN61000-4-6	3 Vr.m.s	perf. Criteria A

Part Number	Input Voltage [VDC]		Output Voltage [VDC]	Output Current [mA, Max]	Capacitive load [μF, max]	Efficiency [Vin. max]
	Nominal	Range				
LMT78_1.5-0.5R	12	4.75-28	1.5	500	680	67
LMT78_1.8-0.5R	12	4.75-28	1.8	500	680	69
LMT78_02-0.5R	12	4.75-32	2.5	500	680	74
LMT78_03-0.5R	24	4.75-36	3.3	500	680	80
LMT78_05-0.5R	24	6.5-36	5	500	680	84
LMT78_6.5-0.5R	24	8-36	6.5	500	680	87
LMT78_09-0.5R	24	12-36	9	500	680	90
LMT78_12-0.5R	24	15-36	12	500	680	91
LMT78_15-0.5R	24	19-36	15	500	680	93

Note: For input voltage higher than 30VDC, a 22μF/50V input capacitor is required.

Typical characteristics

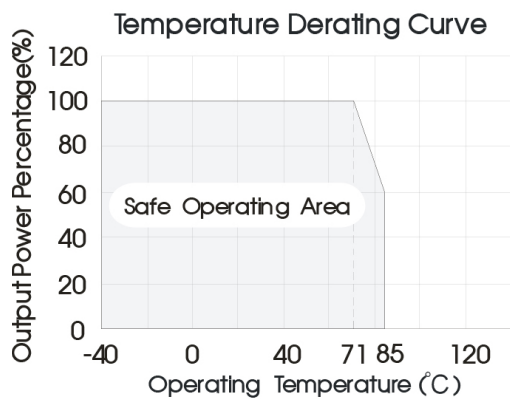

LMT78_0.5R Series

Wide input, non-isolated & regulated, single output, SMD package

Efficiency

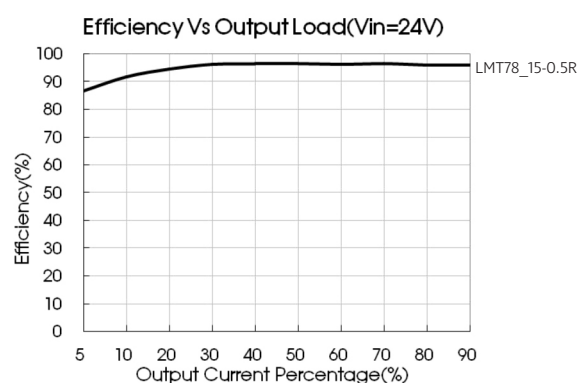
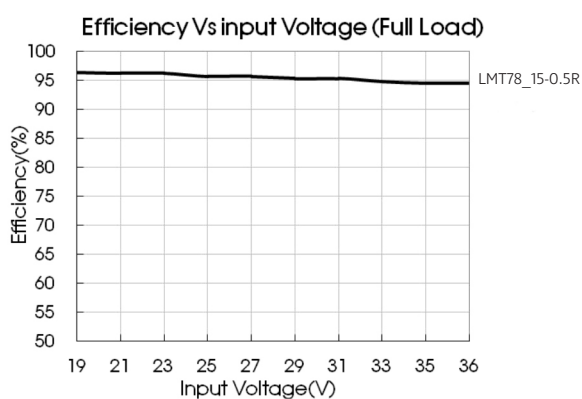
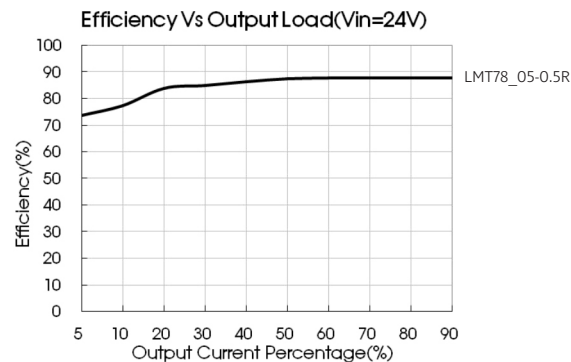
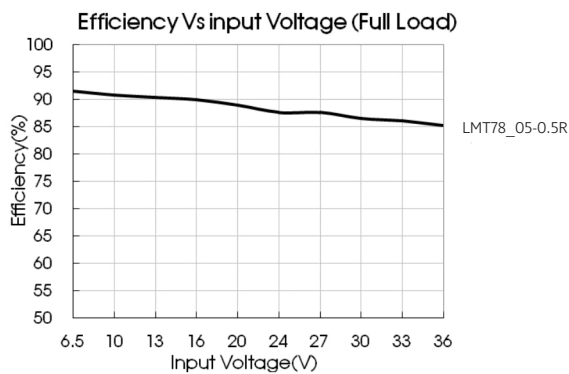

Typical application circuit

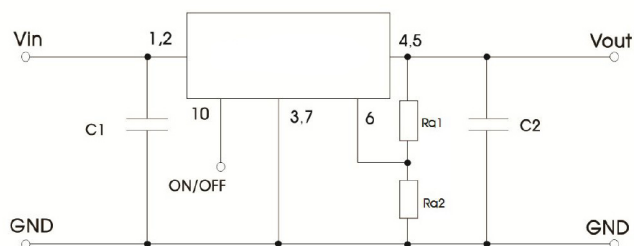

Note:

1. C1 and C2 are required and should be connected close to the pin terminal of the module.
2. The capacitance of C1 and C2 refer to table 1, it can be increased properly if required, and tantalum or low ESR electrolytic capacitors may also suffice.
3. Cannot be used in parallel for output and hot swap.
To reduce the output ripple furtherly, it is suggested to connect a "LC" filter at the output terminal, and recommended value of L is 10 μ H-47 μ H.

Part number	C1 (ceramic capacitor)	C2 (ceramic capacitor)	Ra1/Ra2 (Vadj resistance)
LMT78_1.5-0.5R	10 μ F/50V	22 μ F/10V	Refer to Vadj resistance calculation
LMT78_1.8-0.5R	10 μ F/50V	22 μ F/10V	
LMT78_02-0.5R	10 μ F/50V	22 μ F/10V	
LMT78_03-0.5R	10 μ F/50V	22 μ F/10V	
LMT78_05-0.5R	10 μ F/50V	22 μ F/16V	
LMT78_6.5-0.5R	10 μ F/50V	22 μ F/16V	
LMT78_09-0.5R	10 μ F/50V	22 μ F/25V	
LMT78_12-0.5R	10 μ F/50V	22 μ F/25V	
LMT78_15-0.5R	10 μ F/50V	22 μ F/25V	

Table 1

LMT78_0.5R Series

Wide input, non-isolated & regulated, single output, SMD package

LC filter application circuit

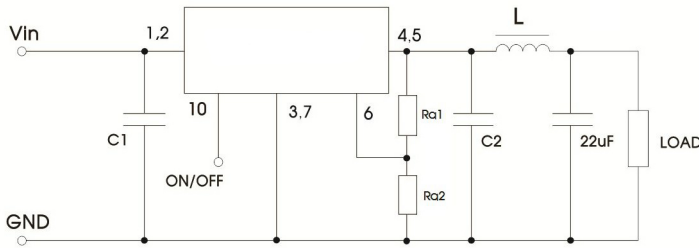

EMC solution-recommended circuit

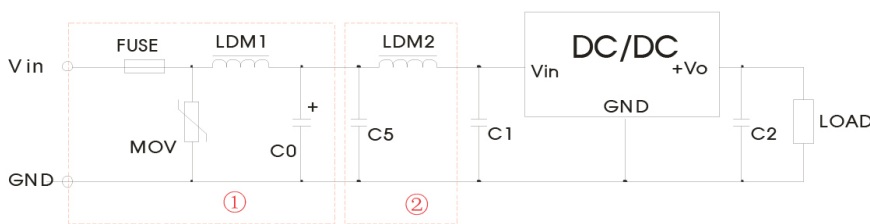

FUSE	Selected based on the actual input current from the customer
MOV	S20K30
LDM1	82μH
C0	680μF/50V
C1/C2	refer to Table 1
C5	4.7μF/50V
LDM2	12μH

Note: Part ① in the Fig. 4 is for EMS test, part ② is for EMI filtering; parts ① and ② can be added based on actual requirement.

Application of Vadj and calculation of Vadj resistance

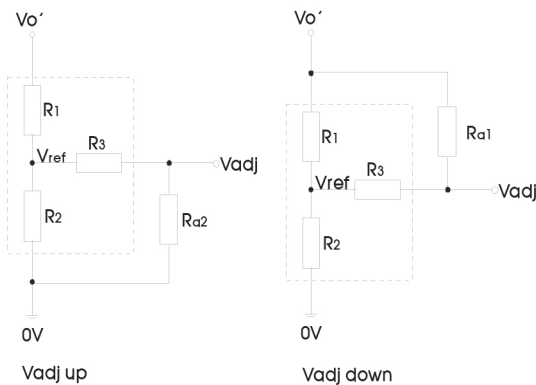

Calculation formula of Vadj resistance:

$$\begin{aligned} \text{up: } R_{a2} &= \frac{\alpha R_2}{R_2 - \alpha} - R_3 & \alpha &= \frac{V_{ref}}{V_{o'} - V_{ref}} \cdot R_1 \\ \text{down: } R_{a1} &= \frac{\alpha R_1}{R_1 - \alpha} - R_3 & \alpha &= \frac{V_{o'} - V_{ref}}{V_{ref}} \cdot R_2 \end{aligned}$$

R_{a1} , R_{a2} is Vadj resistance, α is a self-defined parameter, with no real meaning. $V_{o'}$ for the actual needs of the up or down regulated voltage

Applied circuits of Vadj (Part in broken line is the interior of models)

Vout (V)	R1 (KΩ)	R2 (KΩ)	R3 (KΩ)	Vref (V)
1.5	7.5	7.5	15	0.75
1.8	35.7	26.29	100	0.765
2.5	27	11.858	51	0.765
3.3	33	9.9	47	0.765
5	75	13.5	75	0.765
6.5	75	10	51	0.765
9	51	4.7	27	0.765
12	75	5.1	27	0.765
15	82	4.423	27	0.765

Note: The 1.5VDC output model only support Vadj up, do not support Vadj down.

LMT78_0.5R Series

Wide input, non-isolated & regulated, single output, SMD package

Mechanical dimensions

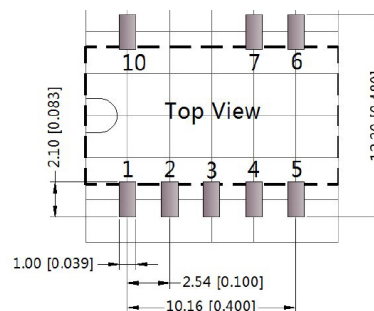
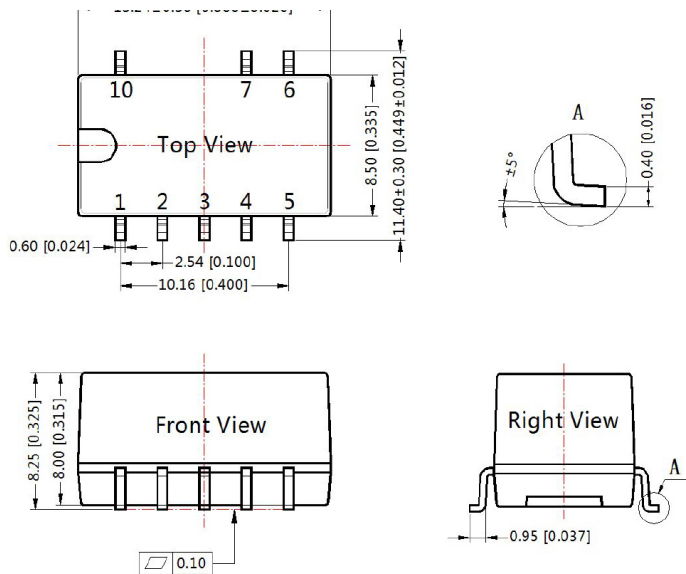

Note: Grid 2.54*2.54mm

Pin-Out	
Pin	Function
1	+Vin
2	+Vin
3	GND
4	+Vout
5	+Vout
6	V adj
7	GND
10	Remote On/Off

Note:
 Unit: mm[inch]
 Pin selection tolerances: $\pm 0.10\text{mm}$ [$\pm 0.004\text{inch}$]
 General tolerances: $\pm 0.25\text{mm}$ [$\pm 0.010\text{inch}$]

NC: Pin to be isolated from circuitry