



Badger Meter Europa GmbH

Registers type ILR7XX and ILR7XXT



INSTALLATION AND OPERATION MANUAL

October 2016

AC_ILR_BA_02_1610

1. Basic safety recommendations	1
2. Register operation.....	3
2.1. Normal operation	3
2.2. Status.....	3
2.3. Totalizers	3
2.4. Flow rate	4
2.5. Battery	4
2.6. Checksum.....	4
2.7. Display scale factor.....	4
3. Register programming.....	5
3.1. Unit of measure	5
3.2. Scale factor.....	5
3.3. Changing the meter pulse rate (for all ILR models with display)	6
3.4. Changing the register orientation (for all ILR models with display).....	6
3.5. Changing the display mode (for all ILR models with display)	7
3.6. Exiting programming mode (for all ILR models with display).....	7
4. Additional programming: Industrial analog and industrial pulse (ILR 710 & ILR 730, ILR750, ILR750T, ILR701, ILR701T).....	8
4.1. Pulse rate out.....	8
4.2. Analog minimum flow rate	9
4.3. Analog maximum flow rate	9
4.4. Linearisation	10
5. Register output specifications & wiring.....	11
5.1. Pulse (model ILR 710)	11
5.2. Dual pulse (model ILR 720)	12
5.3. Analog (model ILR 730).....	13
5.4. Pulse transmitter (model ILR 740)	14
5.5. Pulse and analog output (model ILR750 and 750T)	15
6. Return of goods for repair / Harmlessness declaration	16

1. Basic safety recommendations

Before installing or using this product, please read this instruction manual thoroughly. Only qualified personnel should install and/or repair this product. If a fault appears, contact your distributor.

Before the first installation



Please flush the meter with fresh water or the medium to measure before the first installation.

Installation

Do not place any unit on an unstable surface that may allow it to fall.
Never place the units above a radiator or heating unit.
Route all cabling away from potential hazards.
Isolate from the mains before removing any covers.

Power connection

Use only the type of power source suitable for electronic equipment. If in doubt, contact your distributor. Ensure that any power cables are of a sufficiently high current rating. All units must be earthed to eliminate risk of electric shock. Failure to properly earth a unit may cause damage to that unit or data stored within it.

Protection class

The device has protection class IP 67 and needs to be protected against dripping water, water, oils, etc.

Setup & operation

Adjust only those controls that are covered by the operating instructions. Improper adjustment of other controls may result in damage, incorrect operation or loss of data.

Cleaning

Switch off all units and isolate from mains before cleaning.
Clean using a damp cloth. Do not use liquid or aerosol cleaners.

Repair of faults

Disconnect all units from power supply and have it repaired by a qualified service person if any of the following occurs:

- If any power cord or plug is damaged or frayed
- If a unit does not operate normally when operating instructions are followed
- If a unit exposed to rain/water or if any liquid has been spilled into it
- If a unit has been dropped or damaged
- If a unit shows a change in performance, indicating a need for service.



Failure to adhere to these safety instructions may result in damage to the product or serious bodily injury.



RoHs

Our products are RoHs compliant.

Battery disposal

The batteries contained in our products need to be disposed of as per your local legislation acc. to EU directive 2006/66/EG.



2. Register operation

The following describes register operation and program settings for the industrial oval gear series registers: Industrial Standard (ILR 700 / 701 / 701T), Industrial Pulse (ILR 710 / 750 / 750T), Industrial Quadrature/Dual Pulse (ILR 720) and the Industrial Analog (ILR 730 / 750 / 750T).

The register display consists of two rows of seven-segment digits, status, unit of measures, flow rate, and battery indicators. Operating function settings and programming are provided using the **TOTAL** and **RESET** buttons.



Figure 3: Register display and button

2.1. Normal operation

(for models ILR 7XX)

To enter normal operation mode - when the screen is blank after exiting programming mode, or upon initial use, press either the **TOTAL** or **RESET** button once.

2.2. Status

The status indicators are RESET and TOTAL.

2.3. Totalizers

The top row of indicators is the batch totalizer. This totalizer displays the cumulative volume of flow through the meter with six digits. The batch totalizer totalizes in selected units of measure.

To reset the batch totalizer, after 2 seconds of no flow, press and release the **RESET** button.

NOTE: For the ILR 720 model only, the batch totalizer can be reset by a low pulse on the external reset input.

The bottom row of indicators display the resettable totalizer with five digits or the five least significant digits of the non-resettable totalizer. RESET and TOTAL is indicated when the resettable total is displayed in the five-digit lower row. Only TOTAL is indicated when the non-resettable total is displayed.

To toggle between the non-resettable totalizer and the resettable totalizer, press and release the TOTAL button.



To reset the resettable totalizer, press and hold the TOTAL button and then press and release the RESET button.

To display 11-digit non-resettable totalizer, while the non-resettable total is displayed, press and hold the TOTAL button for seconds. The top row displays the 6 most significant digits; the bottom row displays five least-significant digits.

NOTE: The non-resettable totalizer normally displays 5 least-significant digits.

2.4. Flow rate

PER MIN is displayed in conjunction with the unit of measure. All flow rates are calculated in volume unit per minute.

2.5. Battery

The "LBat" indicator will indicate when the battery is approaching end of life. When the indicator is illuminated, the 2/3AA, 3.0 VDC lithium battery is drained to 10% of its total capacity and should be changed. Normal battery life is five years.

Note: A 2/3AA, 3.6 VDC battery may also be used as a replacement.

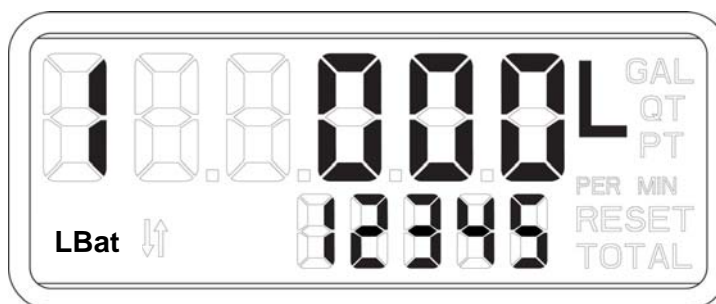

Figure 4: Low battery indicator

2.6. Checksum

To display the firmware checksum, press and hold the RESET button for three seconds. To return to normal display, release the RESET button.

2.7. Display scale factor

To display the scale factor:

At the same time, press and hold the TOTAL and RESET buttons for two seconds to display the programmed scale factor. To return to the normal display, release both buttons.



3. Register programming

In programming mode only, pressing and releasing the **TOTAL** button advances to the next parameter on the current screen. Pressing and releasing the **RESET** button changes the current flashing selection to another selection (such as “L” to “GAL”).

To enter the programming mode, press the TOTAL button three times and then press the RESET button three times (the time lag between pressing both buttons six times must be within two seconds).

Changing the unit of measure and scale factor

(for all ILR models with display)

3.1. Unit of measure

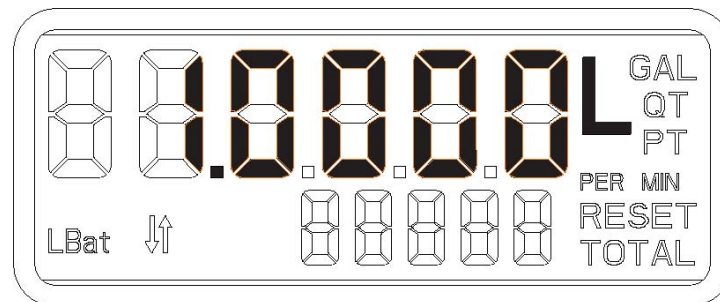

Figure 5: Unit of measure & scale factor programming

1. Press and release the **RESET** button to change the unit of measure (L, GAL, QT, PT).
2. Press and release the **TOTAL** button to select desired the unit of measure (the selected unit of measure will flash).
3. When the appropriate unit of measure is selected, press the **TOTAL** button to advance to the scale factor programming.

3.2. Scale factor

(for all ILR models with display)

The register collects input pulses from the oval gear meter and then determines the appropriate display output using the scale factor. This scale factor varies depending upon the viscosity of the liquid being measured, therefore calibrating the meter and register in the appropriate liquid will affect the scale factor. The scale factor is displayed as 5 digits (on the top row) next to the unit of measure. The scale factor consists of 1 integer digit and 4 decimal digits (see figure 5).

1. Press the **TOTAL** button to select a digit (selected digits flash). After cycling through all 5 digits of the scale factor, the register will return to the unit of measure selection.
2. Press **RESET** to change the selected digit. The scale factor must fall between the values of 0.5000 and 2.0000. The Badger Meter factory preset is set between those values at 1.0000.
3. When finished adjusting the unit of measure and scale factor, press and hold the **TOTAL** button for one second to advance to the Pulse Rate section.



NOTE: Error checking will not allow the user to advance to the next screen.

3.3. Changing the meter pulse rate (for all ILR models with display)

The meter pulse rate (screen is indicated by the “I” on the top row, on the left side) is the number of pulses per unit of measure as detected by the register. The pulse rate varies according to the type of attached meter. The bottom row consists of the 5-digit integer value of the meter pulse rate, whereas the top row consists of the 2-digit decimal value of the meter pulse rate.

The meter pulse rate is entered in pulses per liter if the selected unit of measure is liters. The meter pulse rate is entered in pulses per gallon if the selected unit of measure is gallons, quarts or pints.

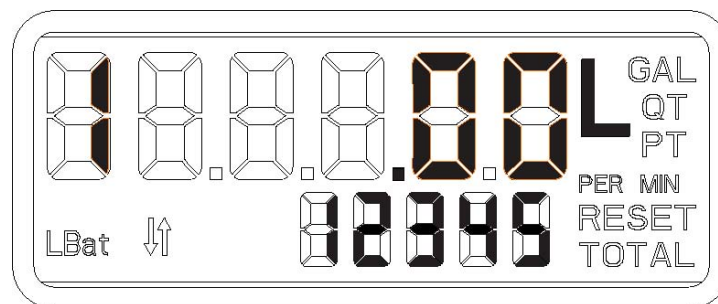

Figure 6: Meter Pulse Rate

1. Press the **TOTAL** button to select a digit (selected digits flash). Press **RESET** to change the selected digit. The pulse rate can be any value between 00000.01 and 99999.99 on the top row; integer values are displayed on the bottom row. Example: 10.45 would display .45 on the top row and 10 would be displayed on the bottom row.
2. When finished adjusting the pulse rate, press and hold the **TOTAL** button for one second to advance to the “register orientation” section.

NOTE: Error checking will not allow the user to advance to the next screen.

3.4. Changing the register orientation (for all ILR models with display)

For oval gear meters: Depending on the orientation perpendicular or inline on the meter.
 For remote version, this will be set to “o”.
 For nutating disc meters (RCDL) set to “O”.
 For turbine meters (Vision) set to “o”.

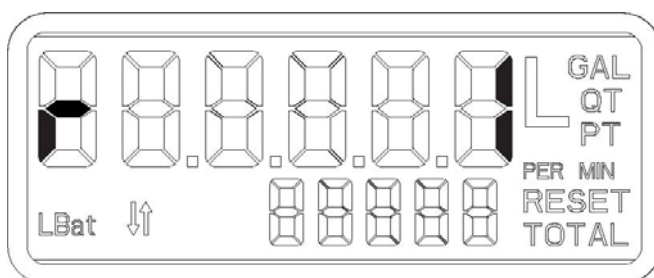
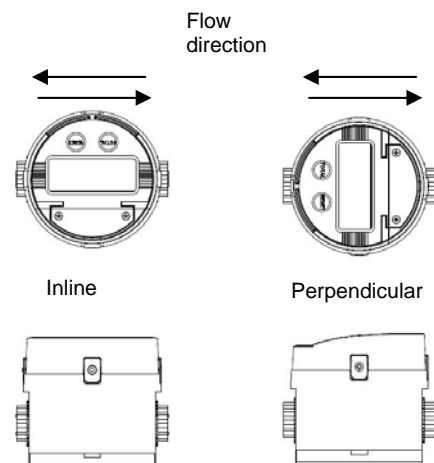

Figure 7: Register orientation



1. Press the **RESET** button to toggle between available options (“I, for an inline-to-flow orientation and “P” for a perpendicular-to-flow orientation or “O” for Remote versions and for the RCDL-nutating disc meters and the Vision turbine meters).
2. When finished adjusting the register orientation, press and hold the **TOTAL** button for one second to advance to the “Default Display” section.

3.5. Changing the display mode (for all ILR models with display)

The display mode screen (indicated by a “d” on the top row, on the left side) determines the information displayed on the top line of the register during normal operation. The display mode may be either the totalizer screen or the flow rate screen.

“C,” indicates the totalizer screen and “F” indicates the flow rate screen. The totalizer screen is depicted below:

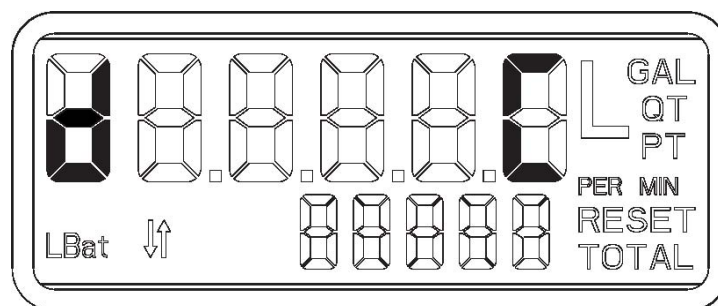

Figure 8: Default display

1. While a letter is flashing on the display, press the **RESET** button to select either totalizer or flow rate.
2. Upon completion of this setting, the programming of the industrial standard register and the industrial dual pulse output is complete. For ILR 710, ILR730, ILR701, ILR701T, ILR750 and ILR750T models, see additional programming parameters.

3.6. Exiting programming mode (for all ILR models with display)

To exit the programming mode:

1. On any screen, press and hold the both the **TOTAL** and **RESET** buttons. The screen will revert back to the programmed scale factor, and then flash. Following the three flashes, the register display will be blank.

Note: Pressing the **TOTAL** or **RESET** buttons will turn the display back on.



4. Additional programming: Industrial analog and industrial pulse (ILR 710 & ILR 730, ILR750, ILR750T, ILR701, ILR701T)

Output pulse length

(for models ILR 710, ILR750 and ILR750T)

Indicated by a “P” on the left hand side of the display, this screen allows the selection of the low duration of the output pulse.

- “0” for zero milliseconds (pulse output is disabled)
- “2” for 2 milliseconds
- “10” for 10 milliseconds
- “20” for 20 milliseconds
- “40” for 40 milliseconds
- “100” for 100 milliseconds

To advance to the next programming screen, hold the **TOTAL** button.

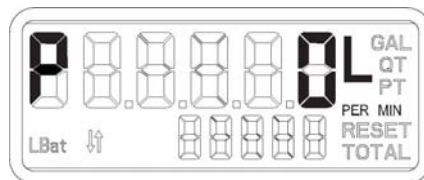

Figure 9: Output pulse length screen

About Output Pulse Length: The pulse rate duration should take into account the "Pulse Rate Out" and maximum meter flow rate, to prevent an output pulse duration greater than the required time between pulses. The Output Pulse Length should be set to less than the value of “t.”

Per the equation:

$$t = \frac{\text{Maximum meter flow rate (in GPM or l/m)}}{60 \times \text{output pulse rate}} \times 1000$$

where t = the required pulse rate in milliseconds.

The output pulse rate = the programmed parameter (default = 1.00 PPL/PPG)

The maximum meter flow rate = the maximum flow rate of the meter for the application.

4.1. Pulse rate out

(for model ILR 710, ILR750 and ILR750T)

Indicated by an “o” on the left hand side of the display, this screen allows selection of the pulses output per liter or per gallon depending on unit of measure (0.01 PPL/PPG to 999 PPL/PPG).

The meter pulse rate is entered in pulses per liter if the selected unit of measure is liters. The meter pulse rate is entered in pulses per gallon if the selected unit of measure is gallons, quarts or pints.

To advance to the next programming screen, hold the **TOTAL** button.

NOTE: Error checking will not allow the user to advance to the next screen.

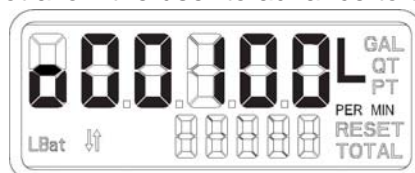

Figure 10: Pulse rate out screen
AC_ILR_BA_02_1610



4.2. Analog minimum flow rate

(for models ILR 730, ILR750 and ILR750T)

Indicated by a “L” on the left hand side of the display, this screen allows the setting of the flow rate that corresponds to the 4mA output:

NOTE: The minimum flow rate value must be less that the maximum flow rate value.

- Minimum 0.0 LPM/GPM
- Maximum 100.0 LPM/GPM
- Default 0.0 LPM/GPM

NOTE: Error checking will not allow the user to advance to the next screen.

To advance to the next programming screen, hold the **TOTAL** button for one second.

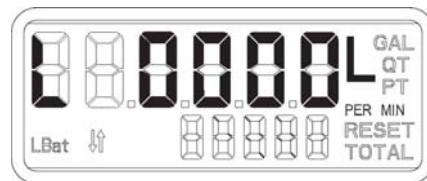

Figure 11: Analog minimum flow rate screen

4.3. Analog maximum flow rate

(for models ILR 730, ILR750 and ILR750T)

Indicated by a “H” on the left hand side of the display, this screen allows the setting of the flow rate that corresponds to the 20mA output:

NOTE: The maximum flow rate value must be greater than the minimum flow rate value.

- Minimum 0.0 LPM/GPM
- Maximum 100.0 LPM/GPM
- Default 30 LPM / 8 GPM

To advance to the next programming screen, hold the **TOTAL** button.

NOTE: Error checking will not allow the user to advance to the next screen.



Figure 12: Analog maximum flow rate screen



4.4. Linearisation

(for models ILR701, ILR701T, ILR750 and ILR750T)

Indicated by 1 – 9 on the left hand side of the display, followed by a hyphen (-), this screen allows the setting of the linearisation (in total 9 points).

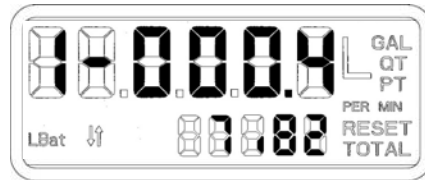

Figure 13: Linearisation point 1 (of 9)

Press the **TOTAL** button to select a digit (selected digits flash). Press **RESET** to change the selected digit. The flow rate will be set in the top row of the meter and is displayed in the unit you selected at step 9.1 (unit of measure). In the sample shown above this would be the flow rate 0.4 liter per minute. On the bottom line of the meter you can set in the correction of the error in %. In the sample below, the error at a flow rate of 0,4 liter per minute would be -7,82%; to correct this, +7,82% needs to be set in (the plus symbol [+] will not be shown).

Once the adjustment of the linearisation is completed, press and hold the **TOTAL** button for one second to advance to the next linearisation point.



Figure 14: Linearisation point 9 (of 9)

Number 9 at the left hand side of the display shows the 9th linearisation point. The sample shows a flow rate of 250.0 liter per minute and a deviation of the flow meter of +0,15%. To correct this error, -0,15% needs to be set as correction.

Note:

- Minimum 3 linearisation points needs to be programmed.
- The flow rates do not have to be programmed from low to high; the software will sort the flow rates automatically, no matter at which point (1-9) they are programmed.

To exit the programming mode:

On any screen, press and hold both the **TOTAL** and **RESET** buttons. The screen will revert back to the programmed scale factor, and then flash. Following the three flashes, the register display will be blank.

Note: Pressing the **TOTAL** or **RESET** buttons will turn the display back on.



5. Register output specifications & wiring

5.1. Pulse (model ILR 710)

Register wiring

External DC+: Yellow

External ground: Brown

Pulse output: White

DC Input: 8 to 24 VDC; 20 to 40mA

Outputs: Pulse output with internal pull-up resistor; optional open collector output with output jumper removal; pulse output is scalable in pulses per liter or pulses per gallon.

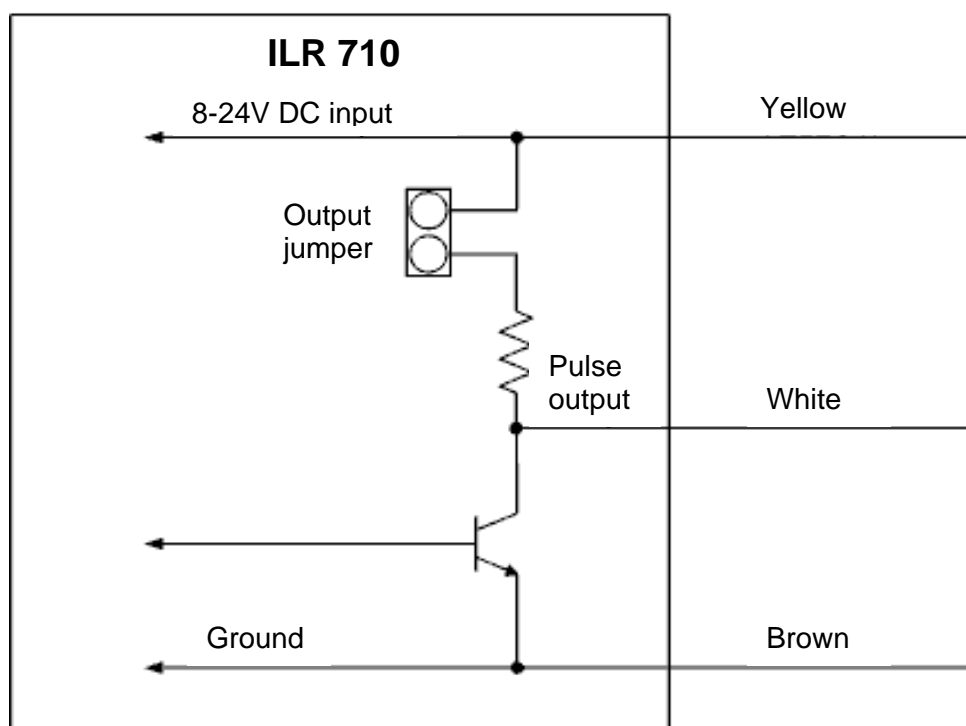

Figure 13: ILR 710 wiring

5.2. Dual pulse (model ILR 720)

Register wiring

External DC+: Yellow

External ground: Brown

Pulse output 1: White

Pulse output 2: Green

External reset: Grey

DC input: 8 to 24 VDC; 20 to 40mA

Outputs: Dual-pulse output with internal pull-up resistor; optional open collector output with output jumper removed; dual pulse output forms a quadrature signal for direction of flow.

Inputs: External reset pulled low to reset the batch totalizer.

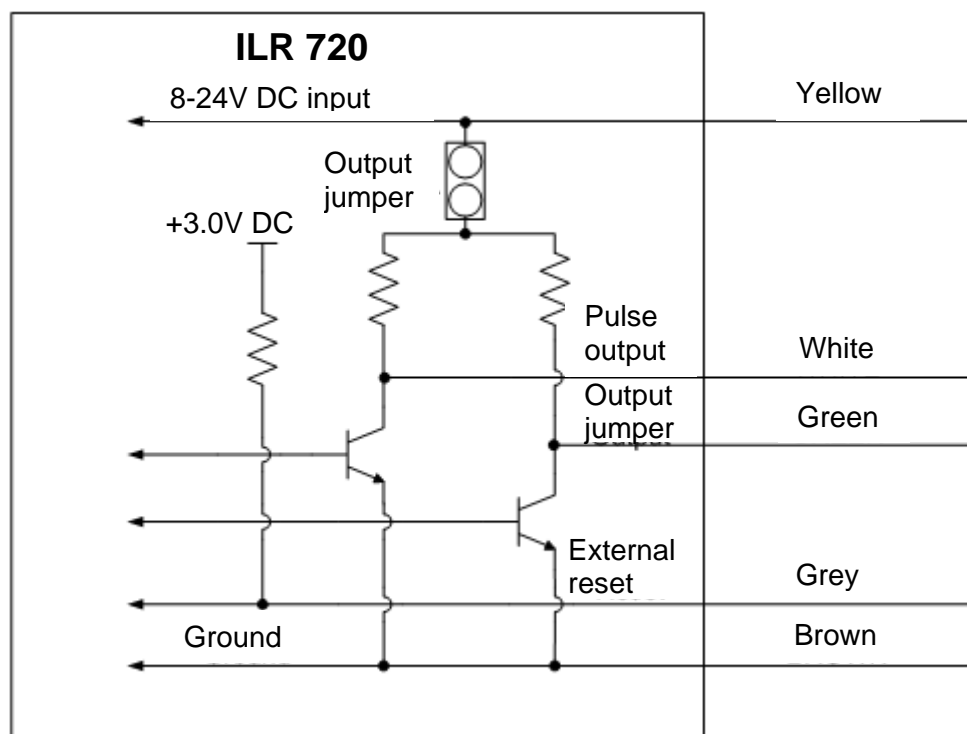

Figure 14: ILR 720 wiring

5.3. Analog (model ILR 730)

Register wiring

External DC+: Yellow

External ground: Brown

Analog output: White

DC input: 8 to 24 VDC; 20 to 40mA

Outputs: Analog 4 to 20mA output in loop powered configuration; external load of 50 ohms to 250 ohms; flow rate is linear scaled between 4mA minimum and 20mA maximum set points; flow rates below programmed minimum read 4mA.

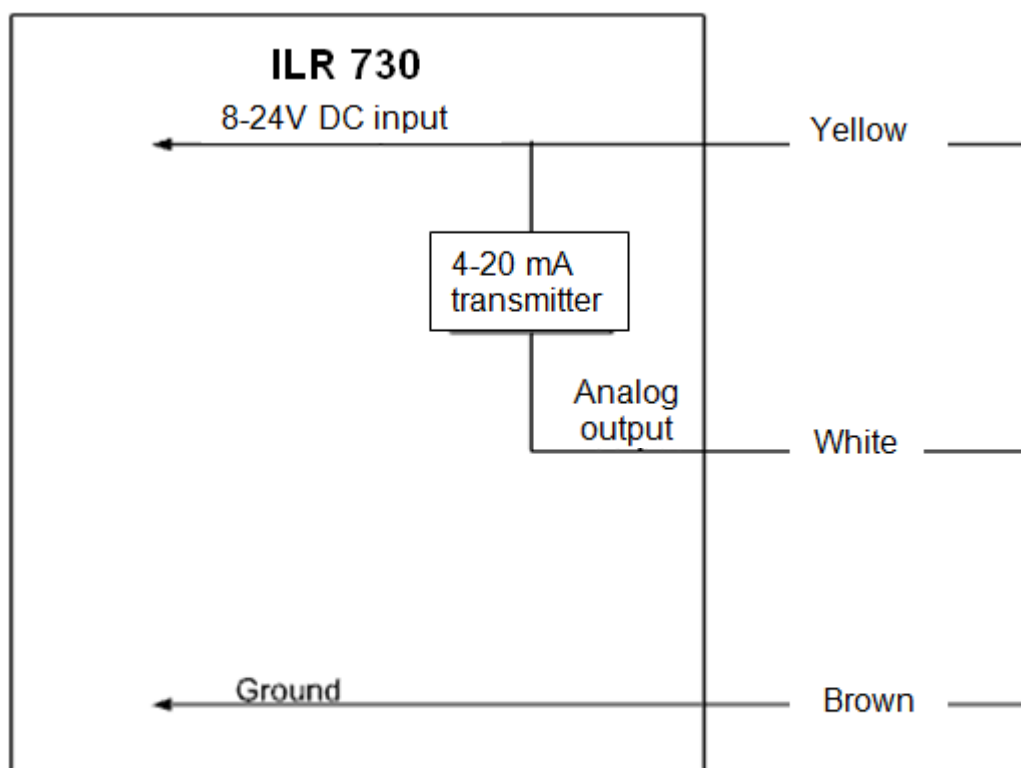

Figure 15: ILR 730 wiring



5.4. Pulse transmitter (model ILR 740)



Figure 16: Pulse transmitter

Orientation: The register must be mounted as delivered. The transmitter will not function if mounted differently.

Transmitter wiring

Reed switch outputs: Green and white.

Ratings: Max power: 10W (not to exceed!); max. voltage: 200 VDC/peak AC; max. current: 0.5A DC/peak AC.

Outputs: Raw reed switch output with no signal conditioning.

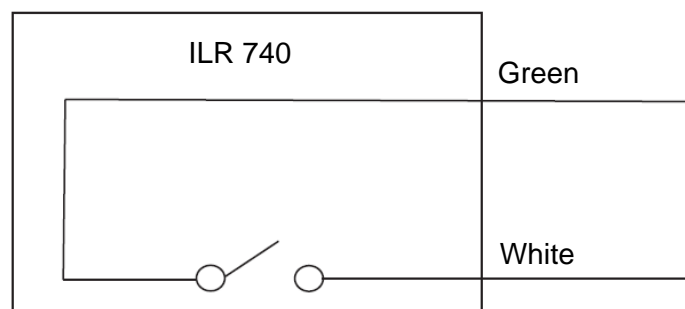

Figure 17: ILR 730 wiring

Pulse per unit of measure (IOG series)

Meter	Pulse per gallon	Pulse per liter
½"	378.5	100
¾"	249.8	66
1"	249.8	66
1" HF	162.8	43
1 ½"	64.4	17
2"	34.1	9
3"	11.4	3

Note: Actual pulses per unit of measure are listed on the calibration certificate provided with the meter.



5.5. Pulse and analog output (model ILR750 and 750T)

Register wiring

External DC+	:	Yellow
External ground	:	Brown
Pulse output	:	White
Analog output	:	Green
DC input	:	8 to 24 VDC; 20 to 40mA

Outputs:

- Analog 4 to 20mA output in loop powered configuration; external load of 50 ohms to 250 ohms; flow rate is linear scaled between 4mA minimum and 20mA maximum set points; flow rates below programmed minimum read 4mA.

- Pulse output with internal pull-up resistor; optional open collector output with output jumper removal; pulse output is scalable in pulses per liter or pulses per gallon.

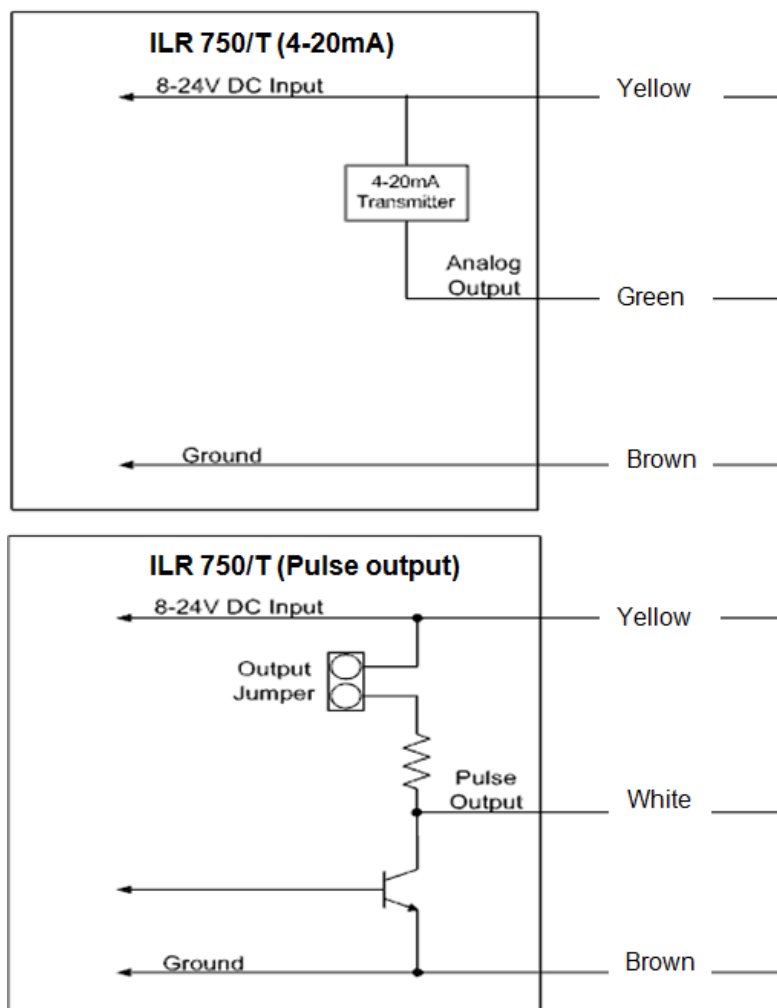

6. Return of goods for repair / Harmlessness declaration

Please refer to our claims return form/harmlessness declaration under [www.badgermeter.de/service/return of goods](http://www.badgermeter.de/service/return_of_goods).





Hotline

Phone +49-7025-9208-0 or -46

Fax +49-7025-9208-15



®

Badger Meter Europa GmbH

Subsidiary of Badger Meter, Inc., USA

Nürtinger Strasse 76

72639 Neuffen (Germany)

E-mail: badger@badgermeter.de

www.badgermeter.de



AC_ILR_BA_02_1610