



### IXARC Absolute Rotary Encoder

### OCD-DPC1B-1416-S10S-HCC



#### Interface

Interface	Profibus DP
Profile	DPV0, DPV1 and DPV2 Class 2 (EN50170 + EN50254)
Diagnostics	Memory
Programming Functions	Resolution, gearing factor (physical resolution) , velocity scaling + filter, preset (zero point), counting direction, limit switches , node number, teach-in, diagnosis
Manual Functions	Address selector switch 0-99 and terminal resistor (with connection cap)
Features	Round Axis
Transmission Rate	≤12 Mbaud
Interface Cycle Time	≥ 1 ms

#### Outputs

Output Driver	Profibus Data Interface, galvanically isolated via opto-couplers
---------------	--

#### Electrical Data

Supply Voltage	10 - 30 VDC
Current Consumption	≤ 115 mA @ 10 V DC, ≤ 50 mA @ 30 V DC
Power Consumption	≤ 1.5 W
Start-Up Time	< 1 s

Data Sheet

Printed at 27-09-2017 15:09

# POSITAL

## FRABA



Reverse Polarity Protection	Yes
Short Circuit Protection	Yes
EMC: Emitted Interference	DIN EN 61000-6-4
EMC: Noise Immunity	DIN EN 61000-6-2
MTTF	13.5 years @ 40 °C

### Sensor

Technology	Optical
Resolution Singleturn	16 bit
Resolution Multiturn	14 bit
Multiturn Technology	Mechanical Gearing (no Battery)
Accuracy (INL)	±0.0220° (14 - 16 bit), ±0.0439° (≤13 bit)
Code	Binary

### Environmental Specifications

Protection Class (Shaft)	IP66/IP67
Protection Class (Housing)	IP66/IP67
Operating Temperature	-40 °C (-40 °F) - +85 °C (+185 °F)
Storage Temperature	-40 °C (-40 °F) - +85 °C (+185 °F)
Humidity	98% RH, no condensation

### Mechanical Data

Connection Cap Material	None
Housing Material	Steel
Housing Coating	Wet coating (RAL 9006 White Aluminium) + Cathodic corrosion protection (>720 h salt spray resistance)
Flange Type	Synchro, ø 58 mm (S)
Flange Material	Aluminum
Shaft Type	Solid, Length = 20 mm
Shaft Diameter	ø 10 mm (0.39")
Shaft Material	Stainless Steel V2A (1.4305, 303)
Max. Shaft Load	Axial 40 N, Radial 110 N
Minimum Mechanical Lifetime (10 <sup>8</sup> revolutions with Fa/Fr)	420 (20 N / 40 N), 145 (40 N / 60 N), 100 (40 N / 80 N), 55 (40 N / 110 N)
Rotor Inertia	≤ 30 gcm <sup>2</sup> [≤ 0.17 oz-in <sup>2</sup> ]
Friction Torque	≤ 5 Ncm @ 20 °C, (7.1 oz-in @ 68 °F)
Max. Permissible Mechanical Speed	≤ 3000 1/min

Data Sheet

Printed at 27-09-2017 15:09

# POSITAL

## FRABA



Shock Resistance	≤ 100 g (half sine 6 ms, EN 60068-2-27)
Permanent Shock Resistance	≤ 10 g (half sine 16 ms, EN 60068-2-29)
Vibration Resistance	≤ 10 g (10 Hz - 1000 Hz, EN 60068-2-6)
Length	56,5 mm (2.22")
Weight	315 g (0.69 lb)

### Electrical Connection

Connection Orientation	Radial
Connection Type	Without Connection Cap

### Certification

Approval	CE + cULus listed, Industrial Control Equipment
Product Life Cycle	Established

### Connection Plan

#### Connector-View on Encoder

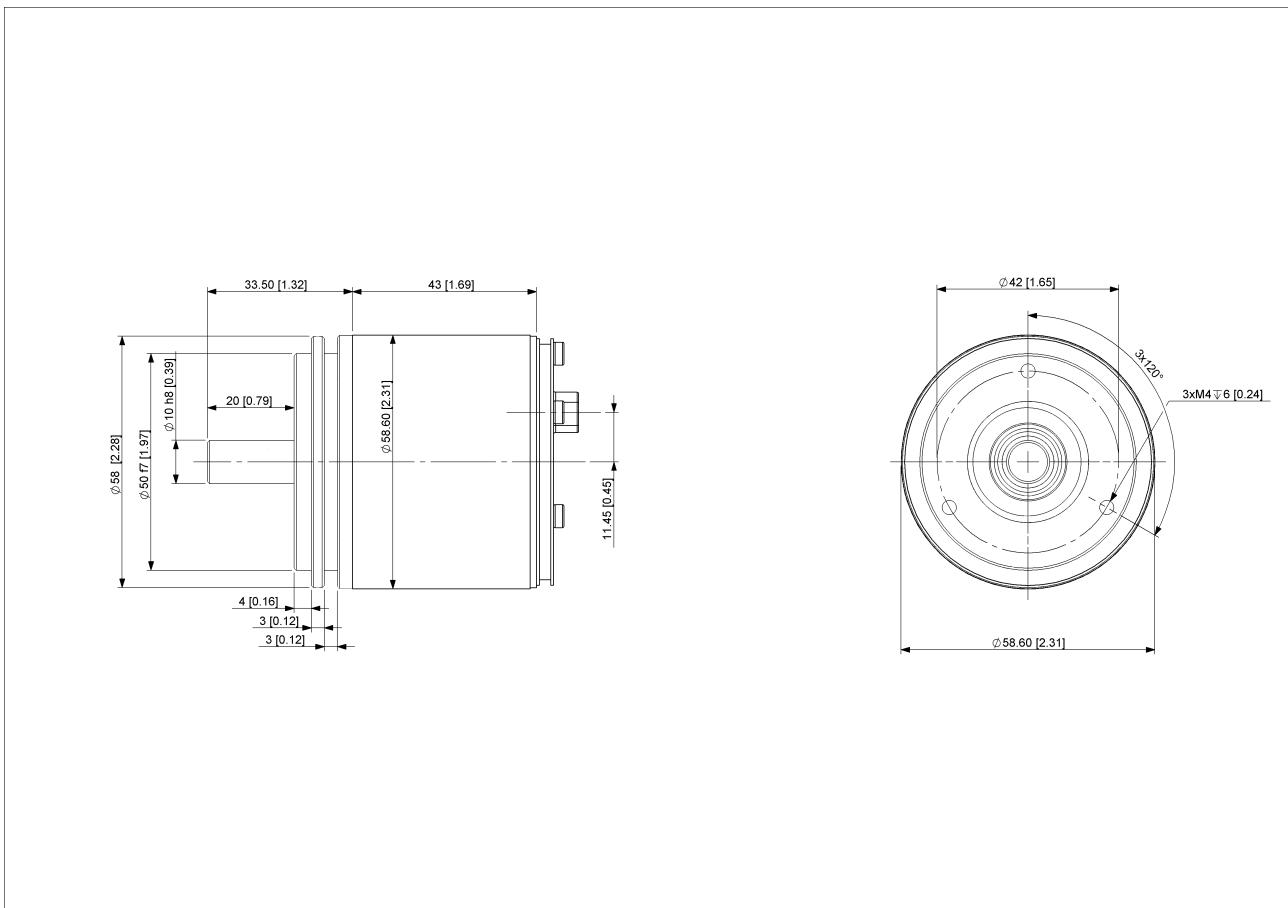

Data Sheet

Printed at 27-09-2017 15:09



### [2D Drawing](#)

#### **Accessories**

Clamp Disc w/ Eccentric Hole-4pcs  
Clamp Disc w/ Centred Hole-4pcs

Coupling Disc Type-10-12  
Coupling Bellow Type-10-10  
Coupling Bellow Type-06-10  
Coupling Bellow Type-08-10  
Coupling Bellow Type-10-12  
Coupling Bellow Type-10-(1/4")  
Coupling Bellow Type-10-(3/8")  
Coupling Jaw Type-06-10  
Coupling Jaw Type-08-10  
Coupling Jaw Type-10-12  
Coupling Jaw Type-10-(1/4")  
Coupling Jaw Type-10-(3/8")  
Coupling Jaw Type-10-10  
Coupling Disc Type-06-10  
Coupling Disc Type-10-10  
More

Mounting Bracket for Synchro Flange w/ fixtures

#### **Contact**



POSITAL  
Contact Us

The picture and drawing are for general presentation purposes only. Please refer to the "Download" section for detailed technical drawings. All dimension in [inch] mm. © FRABA B.V., All rights reserved. We do not assume responsibility for technical inaccuracies or omissions. Specifications are subject to change without notice.

Data Sheet  
Printed at 27-09-2017 15:09