



IXARC Absolute Rotary Encoder

OCD-S6E1G-0016-C060-2AW



Interface

Interface	SSI with Preset + Incremental Push Pull
Optional Incremental Pulses	16384
Manual Functions	Preset + complement via cable or connector
Interface Cycle Time	$\geq 25 \mu\text{s}$

Outputs

Output Driver	SSI (RS422) / Incr. (Push Pull)
Output Incremental	A, /A, B, /B, Z, /Z
Quadrature Phasing	$90^\circ \pm 4.5^\circ$ electrical
Max. Frequency Response	2 MHz

Electrical Data

Supply Voltage	10 - 30 VDC
Power Consumption	$\leq 1.5 \text{ W}$
Start-Up Time	$< 250 \text{ ms}$
Clock Input	RS 422, via Optocoupler
Clock Frequency	100 kHz - 2 MHz
Reverse Polarity Protection	Yes
Short Circuit Protection	Yes
EMC: Emitted Interference	DIN EN 61000-6-4
EMC: Noise Immunity	DIN EN 61000-6-2

Data Sheet

Printed at 27-09-2017 20:09

POSITAL

FRABA



MTTF	16.2 years @ 40 °C
------	--------------------

Sensor

Technology	Optical
Resolution Singleturn	16 bit
Accuracy (INL)	$\pm 0.0220^\circ$ (14 - 16 bit), $\pm 0.0439^\circ$ (≤ 13 bit)
Sense Signal (Default)	Clockwise shaft movement (front view on shaft)
Code	Gray
Incremental Pulses	16384

Environmental Specifications

Protection Class (Shaft)	IP65
Protection Class (Housing)	IP65
Operating Temperature	-30 °C fixed (-22 °F), -5 °C flexible (+23 °F) - +70 °C (+158 °F)
Humidity	98% RH, no condensation

Mechanical Data

Housing Material	Steel
Housing Coating	Cathodic corrosion protection (>720 hrs salt spray resistance)
Flange Type	Clamp, \varnothing 58 mm (C)
Flange Material	Aluminum
Shaft Type	Solid, Length = 10 mm
Shaft Diameter	\varnothing 6 mm (0.24")
Shaft Material	Stainless Steel V2A (1.4305, 303)
Max. Shaft Load	Axial 40 N, Radial 110 N
Minimum Mechanical Lifetime (10 ⁸ revolutions with Fa/Fr)	530 (20 N / 40 N), 185 (40 N / 60 N), 130 (40 N / 80 N), 80 (40 N / 110 N)
Rotor Inertia	≤ 30 gcm ² [≤ 0.17 oz-in ²]
Friction Torque	≤ 3 Ncm @ 20 °C (4.2 oz-in @ 68 °F)
Max. Permissible Mechanical Speed	≤ 12000 1/min
Shock Resistance	≤ 100 g (half sine 6 ms, EN 60068-2-27)
Permanent Shock Resistance	≤ 10 g (half sine 16 ms, EN 60068-2-29)
Vibration Resistance	≤ 10 g (10 Hz - 1000 Hz, EN 60068-2-6)
Length	41,7 mm (1.64")
Weight	275 g (0.61 lb)

Data Sheet
Printed at 27-09-2017 20:09

POSITAL

FRABA



Electrical Connection

Connection Orientation	Axial
Cable Length	2 m [79"]
Wire Cross Section	0.14 mm ² / AWG 26
Material / Type	PVC
Cable Diameter	8 mm (0.31 in)
Minimum Bend Radius	35 mm (1.38) fixed, 70 mm (2.76)

Certification

Approval	CE + cULus listed, Industrial Control Equipment
Product Life Cycle	Established

Connection Plan

SIGNAL	CABLE COLOR
Power Supply	Brown
GND	White
Data+	Gray
Data-	Pink
Clock+	Green
Clock-	Yellow
DIR	Red
Preset	Blue
A	Black
/A	Violet
B	Gray-Pink
/B	Red-Blue
Z	White-Green
/Z	Brown-Green
Shielding	Shield

Connector-View on Encoder

Pulse Diagram

POSITAL

FRABA



Rotation Clockwise (seen on shaft)

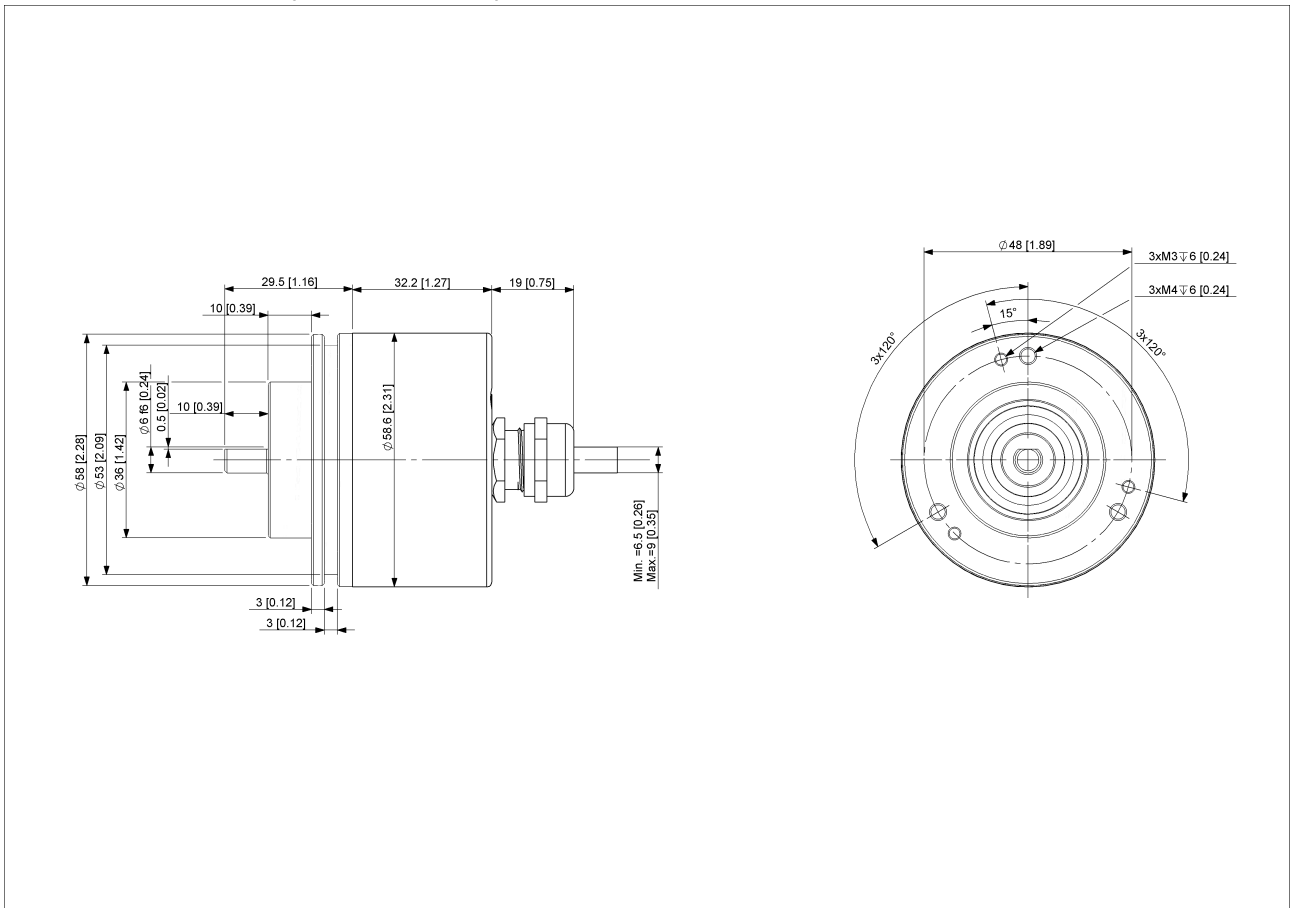

[2D Drawing](#)

Accessories

Clamp Disc w/ Eccentric Hole-4pcs

Clamp Disc w/ Centred Hole-4pcs

Data Sheet

Printed at 27-09-2017 20:09



Coupling Bellow Type-06-06
Coupling Bellow Type-06-10
Coupling Bellow Type-06-08
Coupling Bellow Type-06-(3/8")
Coupling Bellow Type-06-(1/4")
Coupling Jaw Type-06-06
Coupling Jaw Type-06-10
Coupling Jaw Type-06-08
Coupling Jaw Type-06-12
Coupling Jaw Type-06-(1/4")
Coupling Jaw Type-06-(3/8")
Coupling Disc Type-06-06
Coupling Disc Type-06-10
More

Mounting Bracket for Clamping Flange w/ fixtures
L Mounting Bracket w/ screws
Mounting Bracket Spring Loaded f. Clamping Flange

Contact



POSITAL
Contact Us

The picture and drawing are for general presentation purposes only. Please refer to the "Download" section for detailed technical drawings. All dimension in [inch] mm. © FRABA B.V., All rights reserved. We do not assume responsibility for technical inaccuracies or omissions. Specifications are subject to change without notice.