

16X2 LCD MODUL

16x2 LCD module with 16 pin header

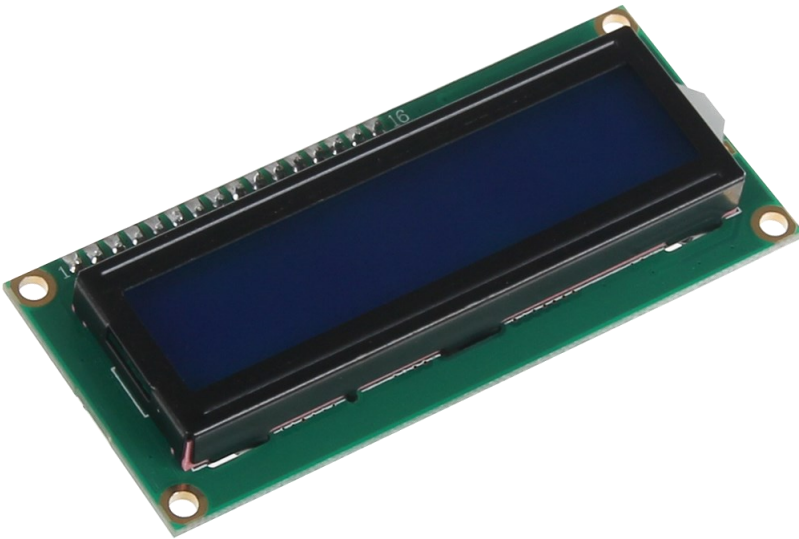

1. GENERAL INFORMATION

Dear customer,
thank you very much for choosing our product.
In the following, we will introduce you to what to observe while starting up and using this product.
Should you encounter any unexpected problems during use, please do not hesitate to contact us.

2. USE WITH THE ARDUINO

2.1 Connection

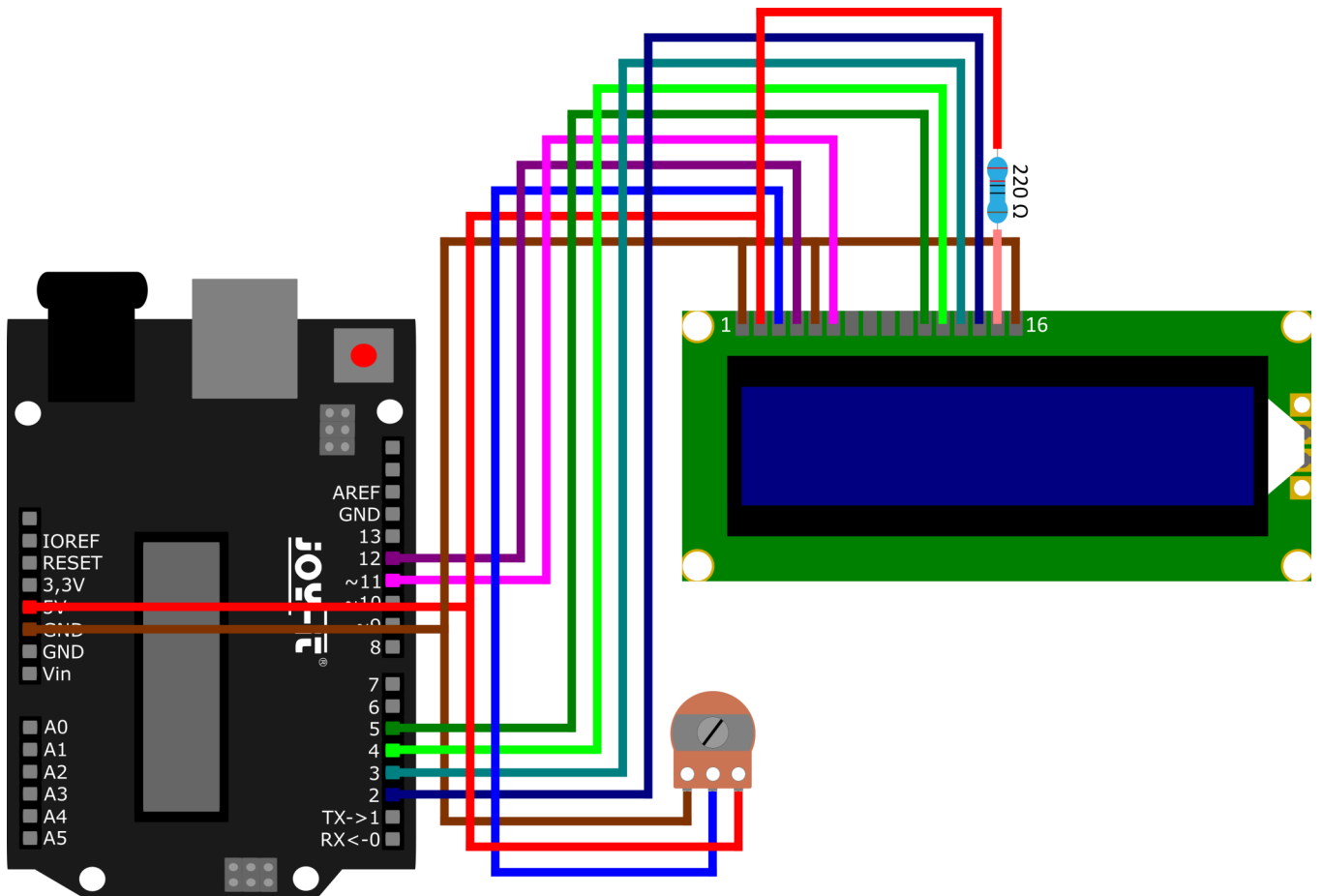

Arduino	Display
D12	Pin 4
D11	Pin 6
D5	Pin 11
D4	Pin 12
D3	Pin 13
D2	Pin 14
GND	Pin 5
GND	Pin 1
5V	Pin 2
5V through a 220Ω resistor	Pin 15
GND	Pin 16

Arduino	Potentiometer	Display
GND	-	
	Signal	Pin 3
5V	+	

2.2. Code example

For use, you can use the library [LiquidCrystal](#) from [Arduino Libraries](#), which is released under the [Creative Commons Attribution-ShareAlike 3.0 License](#).

You can download the library [here](#). You can include the downloaded library into your Arduino IDE by adding the .zip file under **Sketch → Include Library → Add .ZIP Library...** . So select the downloaded library there and restart your Arduino IDE to be able to use the library. You can also go to **Tools → Manage Libraries...** search for *LiquidCrystal* and include the library that way.

Copy the following code into your IDE to test your display. To run the code sample, click **Tools Upload**. Make sure that **Board** and **Port** are selected correctly under Tools.

```
// Import the required library
#include <LiquidCrystal.h>

// initialize the Library by linking each required pin
// LCD interface to the Arduino pin number it is connected to
const int rs = 12, en = 11, d4 = 5, d5 = 4, d6 = 3, d7 = 2;
LiquidCrystal lcd(rs, en, d4, d5, d6, d7);

void setup() {
  // set the number of columns and rows of the LCD
  lcd.begin(16, 2);
}

void loop() {
  // Set cursor to column 7, line 1
  lcd.setCursor(7, 0);
  // Output of the text on the LCD
  lcd.print("joy-IT");
  lcd.setCursor(8, 1);
  // Output of the time in seconds since the last restart
  lcd.print(millis() / 1000);
}
```

3. USE WITH THE RASPBERRY PI

3.1 Connection

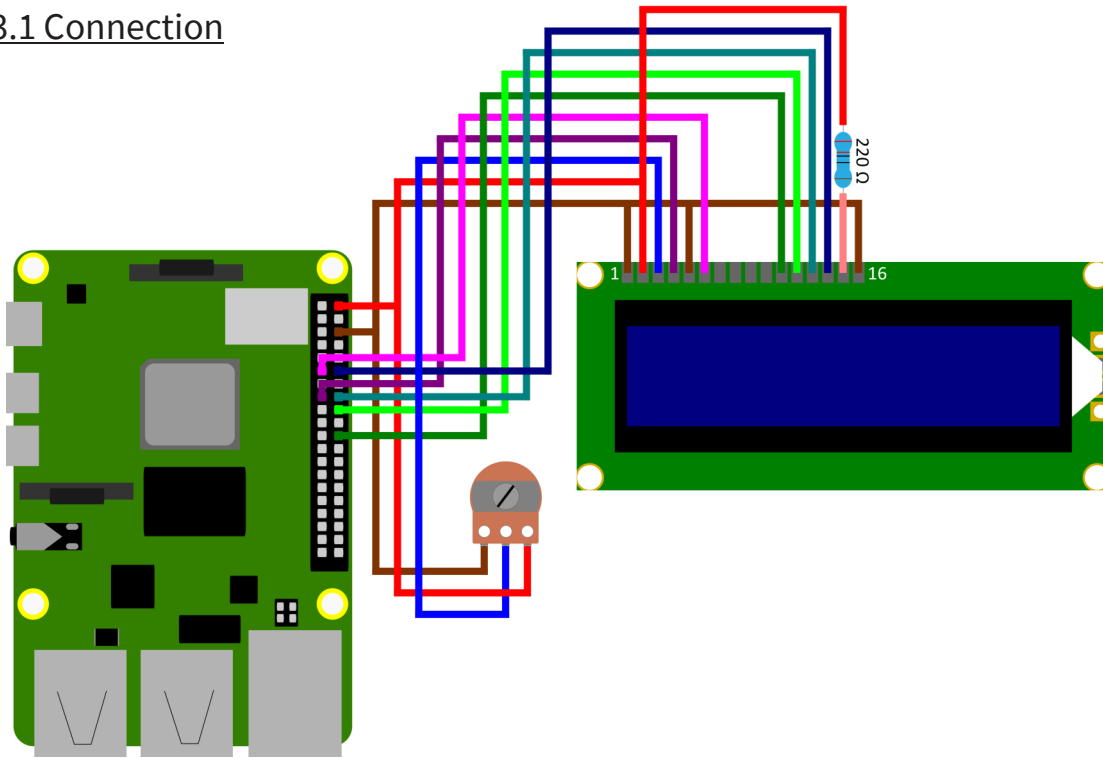

ATTENTION!!!

Since the display works with a 5V logic level, you must use a logic level converter if you want to read data from the display with the Raspberry Pi.

In this example, the display is only written to, so the Raspberry Pi can be connected directly to the display.

Raspberry Pi	Display
GPIO 22 (Pin 15)	Pin 4
GPIO 17 (Pin 13)	Pin 6
GPIO 25 (Pin 22)	Pin 11
GPIO 24 (Pin 17)	Pin 12
GPIO 23 (Pin 16)	Pin 13
GPIO 18 (Pin 12)	Pin 14
GND	Pin 5
GND	Pin 1
5V	Pin 2
5V through a 220Ω resistor	Pin 15
GND	Pin 16

Raspberry Pi	Potentiometer	Display
GND	-	
	Signal	Pin 3
5V	+	

3.2 Code example

We use here the libraries [adafruit-blinka](#) and [adafruit-circuitpython-charlcd](#) which were published by [adafruit](#). They are released under the [MIT license](#).

But before you can use them, you first have to execute the following commands in the console on your Raspberry Pi.

```
sudo apt-get update -y
sudo apt-get upgrade -y
sudo apt-get install python3-pip
```

After you have done this you can now install `adafruit-blinka` and `adafruit-circuitpython-charlcd` on your Raspberry Pi by running the following commands.

```
sudo pip3 install adafruit-blinka
sudo pip3 install adafruit-circuitpython-charlcd
```

Now, after you have installed the two libraries, you can create a new file using the following command

```
nano com-LCD1602.py
```

and there, you can simply copy in the following code.

```
#!/usr/bin/env python3
#-*- coding:utf-8 -*-
from subprocess import Popen, PIPE
from time import sleep
from datetime import datetime
import RPi.GPIO as GPIO
import board
import digitalio
import adafruit_character_lcd.character_lcd as characterlcd

# Change this if you have a different size LCD.
lcd_columns = 16
lcd_rows = 2

lcd_rs = digitalio.DigitalInOut(board.D22)
lcd_en = digitalio.DigitalInOut(board.D17)
lcd_d4 = digitalio.DigitalInOut(board.D25)
lcd_d5 = digitalio.DigitalInOut(board.D24)
lcd_d6 = digitalio.DigitalInOut(board.D23)
lcd_d7 = digitalio.DigitalInOut(board.D18)

# Initialize the LCD
lcd = characterlcd.Character_LCD_Mono(lcd_rs, lcd_en, lcd_d4, lcd_d5, lcd_d6,
lcd_d7, lcd_columns, lcd_rows)

# Search for an active Ethernet or WiFi device
def find_interface():
    find_device = "ip addr show"
    interface_parse = run_cmd(find_device)
    for line in interface_parse.splitlines():
```

```

        if "state UP" in line:
            dev_name = line.split(':')[1]
    return dev_name

# Finding an Active IP Address on the Current Device
def parse_ip():
    find_ip = "ip addr show %s" % interface
    find_ip = "ip addr show %s" % interface
    ip_parse = run_cmd(find_ip)
    for line in ip_parse.splitlines():
        if "inet " in line:
            ip = line.split(' ')[5]
            ip = ip.split('/')[0]
    return ip

# Execute Unix shell command, return as ASCII
def run_cmd(cmd):
    p = Popen(cmd, shell=True, stdout=PIPE)
    output = p.communicate()[0]
    return output.decode('ascii')

# Clear LCD screen before we start
lcd.clear()

# before we start the main loop - detect active network device and IP address
sleep(2)
interface = find_interface()
ip_address = parse_ip()
count = 0

if __name__ == '__main__':
    try:
        while True:
            if count == 0:
                lcd.cursor_position(5, 0)
                lcd.message = "joy-IT"

                lcd.cursor_position(3, 1)
                lcd.message = "for makers"
                sleep(3)
                lcd.cursor_position(1, 1)
                lcd.message = "& Professionals"
                sleep(3)
                lcd.clear()
                count = 1
                sleep(2)

            lcd.cursor_position(0, 0)
            # Output of the date and time on the LCD
            lcd.message = datetime.now().strftime('%b %d %H:%M:%S\n')

            lcd.cursor_position(0, 1)
            # Output of the current IP address on the LCD
            lcd.message = "IP " + ip_address

            sleep(1)

    except KeyboardInterrupt:
        lcd.clear()
        GPIO.cleanup()

```

After you have copied the code into your file you can save the file with **CTRL+O** and close the file with **CTRL+X**.

After that, you can execute the file with the command

```
python3 com-LCD1602.py
```

and watch it on your LCD display.

To interrupt the code just press **CTRL+C**.

Alternatively, you can download the program to your Raspberry Pi with these 3 simple commands, unzip it and then run it.

```
wget https://joy-it.net/files/files/Produkte/com-LCD16x2/com-LCD1602-EN.zip
```

```
unzip com-LCD1602-EN.zip
```

```
python3 com-LCD1602-EN.py
```

4. ADDITIONAL INFORMATION

Our information and take-back obligations according to the Electrical and Electronic Equipment Act (ElektroG)

Symbol on electrical and electronic equipment:



This crossed-out dustbin means that electrical and electronic appliances do not belong in the household waste. You must return the old appliances to a collection point.

Before handing over waste batteries and accumulators that are not enclosed by waste equipment must be separated from it.

Return options:

As an end user, you can return your old device (which essentially fulfils the same function as the new device purchased from us) free of charge for disposal when you purchase a new device.

Small appliances with no external dimensions greater than 25 cm can be disposed of in normal household quantities independently of the purchase of a new appliance.

Possibility of return at our company location during opening hours:

SIMAC Electronics GmbH, Pascalstr. 8, D-47506 Neukirchen-Vluyn, Germany

Possibility of return in your area:

We will send you a parcel stamp with which you can return the device to us free of charge. Please contact us by email at Service@joy-it.net or by telephone.

Information on packaging:

If you do not have suitable packaging material or do not wish to use your own, please contact us and we will send you suitable packaging.

5. SUPPORT

If there are still any issues pending or problems arising after your purchase, we will support you by e-mail, telephone and with our ticket support system.

Email: service@joy-it.net

Ticket system: <http://support.joy-it.net>

Telephone: +49 (0)2845 9360-50 (10-17 o'clock)

For further information please visit our website:

www.joy-it.net