

OMNIMATE Data - RJ45 jacks transformer RJ45G1 R12D 3.3E4YG/YG RL

Weidmüller Interface GmbH & Co. KG
Klingenbergstraße 16
D-32758 Detmold
Germany
Fon: +49 5231 14-0
Fax: +49 5231 14-292083
www.weidmueller.com

Product image



RJ45 transmitter sockets (magnetics) for gigabit applications (1000 base-T) with integrated compensation actively counteracts inductive and capacitive couplings and saves space on the PCB.

The product range encompasses the following designs:

- 90°, lying (horizontal) and 180°, standing (vertical)
- latch up / latch down
- THT, THR or SMD soldering processes
- Wide range of different design types, also with integrated LEDs and shield contact tabs
- Transmission rates of up to 1 Gbps
- Packed either in a tray (TY) or on a roll (tape-on-reel, RL)
- Compatible with modular RJ45 connector according to ANSI / TIA-1096-A and IEC 60603
- Dielectric strength ≥ 1500 V AC RMS (2250 V AC peak value) according to IEEE 802.3
- Dielectric strength ≥ 1500 V AC (peak value) or ≥ 1500 V DC according to IEC 60603
- Compliance with IEEE 802.3 requirements (1000Base-T, 1 Gbps, IEEE 802.3ab or 100Base-Tx, 100 Mbps, IEEE 802.3u)

Properties and advantages:

- Extended temperature range of -40 °C to $+85$ °C for maximum performance
- Reinforced gold layer (30μ "") for improved corrosion protection

- At least 3 mm stand-off ensures a perfect soldering result

General ordering data

Type	RJ45G1 R12D 3.3E4YG/YG RL
Order No.	2036510000
Version	PCB plug-in connector, RJ45 jacks transformer, 1000 Mbps, THT/THR solder connection, 90°, Latch option: bottom, Shield tabs: 6 tabs, 30-80 μ " Ni / 30- μ " Au, LED: Yes, Green/yellow, Green/yellow, No. of poles: 8, Tape
GTIN (EAN)	4050118408409
Qty.	180 pc(s).
Packaging	Tape

**OMNIMATE Data - RJ45 jacks transformer
RJ45G1 R12D 3.3E4YG/YG RL**

Weidmüller Interface GmbH & Co. KG
 Klingenbergstraße 16
 D-32758 Detmold
 Germany
 Fon: +49 5231 14-0
 Fax: +49 5231 14-292083
 www.weidmueller.com

Technical data**Dimensions and weights**

Width	31.2 mm	Width (inches)	1.228 inch
Height	16.9 mm	Height (inches)	0.665 inch
Height of lowest version	13.6 mm	Depth	21.5 mm
Depth (inches)	0.846 inch	Net weight	7.675 g

Temperatures

Operating temperature, max.	85 °C	Operating temperature, min.	-40 °C
Storage temperature, max.	85 °C	Storage temperature, min.	-40 °C

Environmental Product Compliance

REACH SVHC	Lead 7439-92-1
------------	----------------

System specifications

Colour of left LED	Green/yellow	Colour of right LED	Green/yellow
LED	Yes	Latch option	bottom
Mounting onto the PCB	THT/THR solder connection	No. of poles	8
Number of solder pins per pole	1	Outgoing elbow	90°
Pitch in inches (P)	0.05 inch	Pitch in mm (P)	1.27 mm
Plugging cycles	750	Product family	OMNIMATE Data - RJ45 jacks transformer
Protection degree	IP20	Shield surface	nickel-plated
Shield tabs	6 tabs	Shielding	Yes
Shielding material	Brass	Solder eyelet hole diameter (D)	0.9 mm
Solder eyelet hole diameter tolerance (D)	± 0.1 mm	Solder pin dimensions	0.40 x 0.30 mm, LED pins = 0.50 x 0.50 mm
Solder pin length (l)	3.2 mm	Transmission rate	1000 Mbps
Type of connection	Socket connector	Wiring	10-wire

Electrical properties

Dielectric strength, contact / contact	≥ 1000 V DC	Dielectric strength, contact / shield	1500 V DC
Insulation strength	> 500 MΩ	Rated current	1.5 A
Rated voltage	125 V		

Material data

Insulating material	PA 9T	Colour	black
Colour chart (similar)	RAL 9011	Insulating material group	II
CTI	≥ 500	Insulation strength	> 500 MΩ
Moisture Level (MSL)	1	UL 94 flammability rating	V-0
Contact base material	Phosphorus bronze	Contact surface	Gold over nickel
Layer structure of plug contact	30-80 μ" Ni / 30- μ" Au	Storage temperature, min.	-40 °C
Storage temperature, max.	85 °C	Operating temperature, min.	-40 °C
Operating temperature, max.	85 °C		

Packing

Packaging	Tape	VPE length	0 m
VPE width	0 m	VPE height	0 m
Tape reel diameter ø (A)	330 mm	Surface resistance	Rs = 10 ⁹ - 10 ¹² Ω

Creation date May 27, 2019 1:58:26 PM CEST

Data sheet

**OMNIMATE Data - RJ45 jacks transformer
RJ45G1 R12D 3.3E4YG/YG RL**

Weidmüller Interface GmbH & Co. KG
 Klingenbergstraße 16
 D-32758 Detmold
 Germany
 Fon: +49 5231 14-0
 Fax: +49 5231 14-292083
 www.weidmueller.com

Technical data

Classifications

ETIM 6.0	EC002637	eClass 6.2	27-25-05-04
eClass 9.0	27-44-04-02	eClass 9.1	27-44-04-02

Approvals

Approvals



ROHS Conform

Downloads

Brochure/Catalogue	MB FREECONTACT EN FL FIELDWIRING EN PI PROFINET CABLING EN
Engineering Data	STEP
User Documentation	MAN IE GUIDE DE MAN IE GUIDE EN

**OMNIMATE Data - RJ45 jacks transformer
RJ45G1 R12D 3.3E4YG/YG RL**

Weidmüller Interface GmbH & Co. KG
 Klingenbergstraße 16
 D-32758 Detmold
 Germany
 Fon: +49 5231 14-0
 Fax: +49 5231 14-292083
 www.weidmueller.com

Drawings

Dimensioned drawing

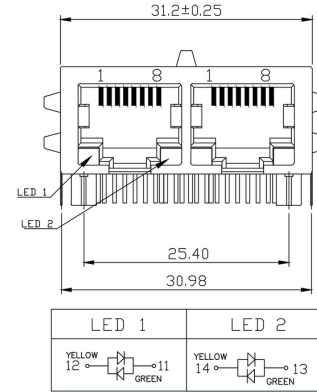

Dimensioned drawing

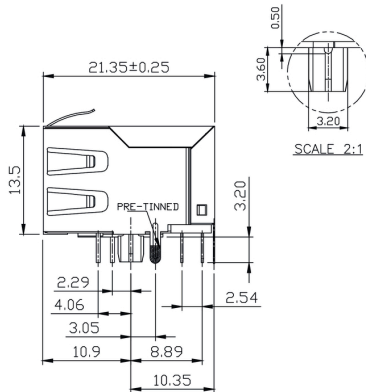

PCB design

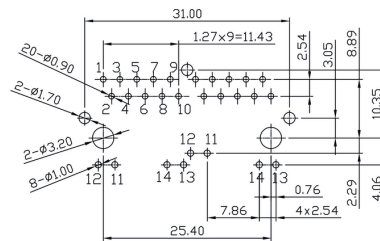

Wiring diagram

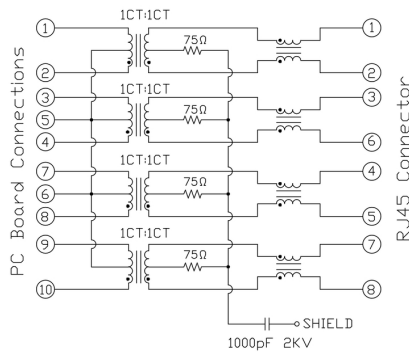

OMNIMATE Data - RJ45 jacks transformer RJ45G1 R12D 3.3E4YG/YG RL

Weidmüller Interface GmbH & Co. KG
 Klingenbergstraße 16
 D-32758 Detmold
 Germany
 Fon: +49 5231 14-0
 Fax: +49 5231 14-292083
 www.weidmueller.com

Drawings

Schematic

Characteristics

Inductance	350 µH min. @ 100 kHz, 100 mV, 8 mA DC Bias
Leakage Inductance	0.3 µH max. @ 100 kHz, 100 mV
Insertion Loss	1.1 dB max. @ (1 - 100) MHz
Return Loss	18 dB min. @ (1 - 30) MHz 16 dB min. @ (30 - 60) MHz 12 dB min. @ (60 - 80) MHz
Cross Talk	30 dB min. @ (1 - 100) MHz
Common Mode Rejection	30 dB min. @ (1 - 100) MHz

Type codes

Type Code	Parameter	Value	Description
RJ45	Product	RJ45	Product
G1	Performance Category	G1	Category 5, 10/100/1000 Mbit
R	Assembly on PCB	R	Through Hole Reflow - THR
U	Direction, latch style	U	Horizontal (90°, side entry), latch up
3.2	Solder Pin length	3.2	3.2 mm
E	EMI tabs (ground fingers)	E	E = with EMI tabs
4	Contact surface thickness	4	1 = 3µ", 2 = 6µ", 3 = 15µ", 4 = 30µ", 5 = 50µ"
GY/GY	LED	GY/GY	Green-Yellow/Green-Yellow
TY	Packaging	TY	Tray in box (manual assembly)
		RL	Tape on Reel (automated assembly)
		Y/G	Yellow/Green
		G/Y	Green/Yellow (standard)
		GY/GY	Green-Yellow/Green-Yellow
		O/G	Orange/Green
		R/O	Red/Orange
	 (further combinations possible)
		N	without LED
		N	without EMI tabs
		D	SMD
		S	Surface Mount Technology - SMT
		T	Through Hole Technology - THT
		MP	10/100 Mbit with POE
		MP+	10/100 Mbit with POE+

Recommended wave soldering profiles

Weidmüller Interface GmbH & Co. KG
 Klingenbergstraße 16
 D-32758 Detmold
 Germany
 Fon: +49 5231 14-0
 Fax: +49 5231 14-292083
 www.weidmueller.com

Single Wave:



Double Wave:



Wave soldering profiles

Wired connection elements should be processed in accordance with the DIN EN 61760-1 standard. We have included two recommendations for practical wave soldering profiles, with which Weidmüller PCB terminals and connectors are qualified.

When choosing a suitable profile for your application, the following factors also need to be considered:

- PCB thickness
- Proportion of Cu in the layers
- Single/double-sided assembly
- Product range
- Heating and cooling rates

The single and double wave profiles each indicate the recommended operating range, including the maximum soldering temperature of 260°C. In practice, the maximum soldering temperature is quite often well below the above maximum profile.

Recommended reflow soldering profile

Weidmüller Interface GmbH & Co. KG
 Klingenbergstraße 16
 D-32758 Detmold
 Germany
 Fon: +49 5231 14-0
 Fax: +49 5231 14-292083
 www.weidmueller.com



Reflow soldering profile

The perfect soldering profile for SMT Surface Mount Technology is one the most exiting question in SMT production. But there are more than one correct answer: The diagram of temperature-on-time is related to processing features of solder paste and to maximum load of components.

We have to consider the following parameters:

- Time for pre heating
- Maximum temperature
- Time above melting point
- Time for cooling
- Maximum heating rate
- Maximum cooling rate

We recommend a typical solder profile with associated process limits. With preheating components and board are prepared smoothly for the solder phase. Heating rate is typically $\leq +3\text{K/s}$. In parallel the solder paste is ‚activated‘. The time above melting point of 217°C the paste gets liquid and components and boards begin to connect. The maximum temperature of 245°C to 254°C should stay between 10 and 40 seconds. In the cooling phase at $\geq -6\text{K/s}$ solder is cured. Board and components cool down while avoiding cold cracks.