

Traction contactor, AC-3 12 A, 5.5 kW / 400 V 24 V DC 0.7-1.25* US, with varistor integrated, 3-pole Size S00, Spring-type terminal Spring-type terminal upright mounting position



Product brand name	SIRIUS
Product designation	Power contactor
Product type designation	3RT2
General technical data	
Size of contactor	S00
Product extension	
• function module for communication	No
• Auxiliary switch	No
Insulation voltage	
• of main circuit with degree of pollution 3 rated value	690 V
• of auxiliary circuit with degree of pollution 3 rated value	690 V
Surge voltage resistance	
• of main circuit rated value	6 kV
• of auxiliary circuit rated value	6 kV
maximum permissible voltage for safe isolation	
• between coil and main contacts acc. to EN 60947-1	400 V

Protection class IP	
• on the front	IP20
• of the terminal	IP20
Shock resistance at rectangular impulse	
• at DC	7.3g / 5 ms, 4.7g / 10 ms
Shock resistance with sine pulse	
• at DC	11,4g / 5 ms, 7,3g / 10 ms
Mechanical service life (switching cycles)	
• of contactor typical	30 000 000
Reference code acc. to DIN EN 81346-2	Q

Ambient conditions

Installation altitude at height above sea level	
• maximum	2 000 m

Main circuit

Number of poles for main current circuit	3
Number of NO contacts for main contacts	3
Operating voltage	
• at AC-3 rated value maximum	690 V
Operating current	
• at AC-1 at 400 V	
— rated value	22 A
— at ambient temperature 40 °C rated value	22 A
• at AC-1	
— up to 690 V at ambient temperature 40 °C rated value	22 A
— up to 690 V at ambient temperature 60 °C rated value	20 A
• at AC-2 at 400 V rated value	12 A
• at AC-3	
— at 400 V rated value	12 A
— at 500 V rated value	9.2 A
— at 690 V rated value	6.7 A
• at AC-4 at 400 V rated value	8.5 A
Minimum cross-section in main circuit	
• at maximum AC-1 rated value	4 mm ²
Operating current for approx. 200000 operating cycles at AC-4	
• at 400 V rated value	4.1 A
• at 690 V rated value	3.3 A
Operating current	
• at 1 current path at DC-1	
— at 24 V rated value	20 A

— at 110 V rated value	2.1 A
— at 220 V rated value	0.8 A
— at 440 V rated value	0.6 A
— at 600 V rated value	0.6 A
• with 2 current paths in series at DC-1	
— at 24 V rated value	20 A
— at 110 V rated value	12 A
— at 220 V rated value	1.6 A
— at 440 V rated value	0.8 A
— at 600 V rated value	0.7 A
• with 3 current paths in series at DC-1	
— at 24 V rated value	20 A
— at 110 V rated value	20 A
— at 220 V rated value	20 A
— at 440 V rated value	1.3 A
— at 600 V rated value	1 A
Operating current	
• at 1 current path at DC-3 at DC-5	
— at 24 V rated value	20 A
— at 110 V rated value	0.1 A
• with 2 current paths in series at DC-3 at DC-5	
— at 24 V rated value	20 A
— at 110 V rated value	0.35 A
• with 3 current paths in series at DC-3 at DC-5	
— at 24 V rated value	20 A
— at 110 V rated value	20 A
— at 220 V rated value	1.5 A
— at 440 V rated value	0.2 A
— at 600 V rated value	0.2 A
Operating power	
• at AC-1	
— at 230 V at 60 °C rated value	7.5 kW
— at 400 V rated value	13 kW
— at 400 V at 60 °C rated value	13 kW
— at 690 V at 60 °C rated value	22 kW
• at AC-2 at 400 V rated value	5.5 kW
• at AC-3	
— at 230 V rated value	3 kW
— at 400 V rated value	5.5 kW
— at 500 V rated value	5.5 kW
— at 690 V rated value	5.5 kW

Operating power for approx. 200000 operating cycles at AC-4	
• at 400 V rated value	2 kW
• at 690 V rated value	2.5 kW
Thermal short-time current limited to 10 s	90 A
Power loss [W] at AC-3 at 400 V for rated value of the operating current per conductor	1.2 W
No-load switching frequency	
• at DC	10 000 1/h

Control circuit/ Control

Type of voltage	DC
Type of voltage of the control supply voltage	DC
Control supply voltage at DC	
• rated value	24 V
Operating range factor control supply voltage rated value of magnet coil at DC	
• initial value	0.7
• Full-scale value	1.25
Design of the surge suppressor	with varistor
Inrush current peak	
• at 24 V	2.3 A
Duration of inrush current peak	
• at 24 V	50 µs
Closing power of magnet coil at DC	13 W
Holding power of magnet coil at DC	4 W
Closing delay	
• at DC	30 ... 100 ms
Opening delay	
• at DC	7 ... 13 ms
Arcing time	10 ... 15 ms
Control version of the switch operating mechanism	E1 - A2

Auxiliary circuit

Number of NC contacts for auxiliary contacts	1
• instantaneous contact	1
Operating current at AC-12 maximum	10 A
Operating current at AC-15	
• at 230 V rated value	10 A
• at 400 V rated value	3 A
• at 500 V rated value	2 A
• at 690 V rated value	1 A
Operating current at DC-12	
• at 24 V rated value	10 A

<ul style="list-style-type: none"> • at 48 V rated value • at 60 V rated value • at 110 V rated value • at 125 V rated value • at 220 V rated value • at 600 V rated value 	<p>6 A</p> <p>6 A</p> <p>3 A</p> <p>2 A</p> <p>1 A</p> <p>0.15 A</p>
Operating current at DC-13	
<ul style="list-style-type: none"> • at 24 V rated value • at 48 V rated value • at 60 V rated value • at 110 V rated value • at 125 V rated value • at 220 V rated value • at 600 V rated value 	<p>10 A</p> <p>2 A</p> <p>2 A</p> <p>1 A</p> <p>0.9 A</p> <p>0.3 A</p> <p>0.1 A</p>
Contact reliability of auxiliary contacts	1 faulty switching per 100 million (17 V, 1 mA)
UL/CSA ratings	
Full-load current (FLA) for three-phase AC motor	
<ul style="list-style-type: none"> • at 480 V rated value • at 600 V rated value 	<p>11 A</p> <p>11 A</p>
Yielded mechanical performance [hp]	
<ul style="list-style-type: none"> • for single-phase AC motor <ul style="list-style-type: none"> — at 110/120 V rated value — at 230 V rated value • for three-phase AC motor <ul style="list-style-type: none"> — at 200/208 V rated value — at 220/230 V rated value — at 460/480 V rated value — at 575/600 V rated value 	<p>0.5 hp</p> <p>2 hp</p> <p>3 hp</p> <p>3 hp</p> <p>7.5 hp</p> <p>10 hp</p>
Contact rating of auxiliary contacts according to UL	A600 / Q600
Short-circuit protection	
Product function Short circuit protection	No
Design of the fuse link	
<ul style="list-style-type: none"> • for short-circuit protection of the main circuit <ul style="list-style-type: none"> — with type of coordination 1 required — with type of assignment 2 required • for short-circuit protection of the auxiliary switch required 	<p>gG: 50A (690V,100kA), aM: 20A (690V,100kA), BS88: 35A (415V,80kA)</p> <p>gG: 20A (690V,100kA), aM: 16A (690V, 100kA), BS88: 20A (415V, 80kA)</p> <p>gG: 10 A (500 V, 1 kA)</p>
Installation/ mounting/ dimensions	
Mounting position	standing, on horizontal mounting surface

Mounting type	screw and snap-on mounting onto 35 mm standard mounting rail according to DIN EN 60715
<ul style="list-style-type: none"> • Side-by-side mounting 	Yes
Height	70 mm
Width	45 mm
Depth	117 mm
Required spacing	
<ul style="list-style-type: none"> • with side-by-side mounting <ul style="list-style-type: none"> — forwards — upwards — downwards — at the side • for grounded parts <ul style="list-style-type: none"> — forwards — upwards — at the side — downwards • for live parts <ul style="list-style-type: none"> — forwards — upwards — downwards — at the side 	10 mm 10 mm 10 mm 0 mm 10 mm 10 mm 6 mm 10 mm 10 mm 10 mm 10 mm 6 mm

Connections/ Terminals	
Type of electrical connection	
<ul style="list-style-type: none"> • for main current circuit • for auxiliary and control current circuit • at contactor for auxiliary contacts • of magnet coil 	spring-loaded terminals spring-loaded terminals Spring-type terminals Spring-type terminals
Type of connectable conductor cross-sections	
<ul style="list-style-type: none"> • for main contacts <ul style="list-style-type: none"> — solid — single or multi-stranded — finely stranded with core end processing — finely stranded without core end processing • at AWG conductors for main contacts 	2x (0.5 ... 1.5 mm ²), 2x (0.75 ... 2.5 mm ²), 2x 4 mm ² 2x (0,5 ... 4 mm ²) 2x (0.5 ... 2.5 mm ²) 2x (0.5 ... 2.5 mm ²) 2x (20 ... 12)
Type of connectable conductor cross-sections	
<ul style="list-style-type: none"> • for auxiliary contacts <ul style="list-style-type: none"> — single or multi-stranded — finely stranded with core end processing — finely stranded without core end processing 	2x (0,5 ... 4 mm ²) 2x (0.5 ... 2.5 mm ²) 2x (0.5 ... 2.5 mm ²)

<ul style="list-style-type: none"> • at AWG conductors for auxiliary contacts 	2x (20 ... 12)
AWG number as coded connectable conductor cross section	
<ul style="list-style-type: none"> • for main contacts 	20 ... 12
<ul style="list-style-type: none"> • for auxiliary contacts 	20 ... 12

Safety related data

B10 value	
<ul style="list-style-type: none"> • with high demand rate acc. to SN 31920 	1 000 000
Proportion of dangerous failures	
<ul style="list-style-type: none"> • with low demand rate acc. to SN 31920 	40 %
<ul style="list-style-type: none"> • with high demand rate acc. to SN 31920 	73 %
Failure rate [FIT]	
<ul style="list-style-type: none"> • with low demand rate acc. to SN 31920 	100 FIT
Product function	
<ul style="list-style-type: none"> • Mirror contact acc. to IEC 60947-4-1 	Yes
<ul style="list-style-type: none"> • positively driven operation acc. to IEC 60947-5-1 	No
T1 value for proof test interval or service life acc. to IEC 61508	20 y
Protection against electrical shock	finger-safe

Communication/ Protocol

Product function Bus communication	No
---	----

Certificates/ approvals

General Product Approval	EMC
--------------------------	-----



[KC](#)



Functional Safety/Safety of Machinery	Declaration of Conformity	Test Certificates	Marine / Shipping
---------------------------------------	---------------------------	-------------------	-------------------

[Type Examination Certificate](#)



[Miscellaneous](#)

[Type Test Certificates/Test Report](#)

[Special Test Certificate](#)



Marine / Shipping



other	Railway
-------	---------

[Confirmation](#)



[Special Test Certificate](#)

Further information

Information- and Downloadcenter (Catalogs, Brochures,...)

www.siemens.com/sirius/catalogs

Industry Mall (Online ordering system)

<https://mall.industry.siemens.com/mall/en/en/Catalog/product?mlfb=3RT2017-2LB42-1LA0>

Cax online generator

<http://support.automation.siemens.com/WW/CAXorder/default.aspx?lang=en&mlfb=3RT2017-2LB42-1LA0>

Service&Support (Manuals, Certificates, Characteristics, FAQs,...)

<https://support.industry.siemens.com/cs/ww/en/ps/3RT2017-2LB42-1LA0>

Image database (product images, 2D dimension drawings, 3D models, device circuit diagrams, EPLAN macros, ...)

http://www.automation.siemens.com/bilddb/cax_de.aspx?mlfb=3RT2017-2LB42-1LA0&lang=en

Characteristic: Tripping characteristics, I²t, Let-through current

<https://support.industry.siemens.com/cs/ww/en/ps/3RT2017-2LB42-1LA0/char>

Further characteristics (e.g. electrical endurance, switching frequency)

<http://www.automation.siemens.com/bilddb/index.aspx?view=Search&mlfb=3RT2017-2LB42-1LA0&objecttype=14&gridview=view1>

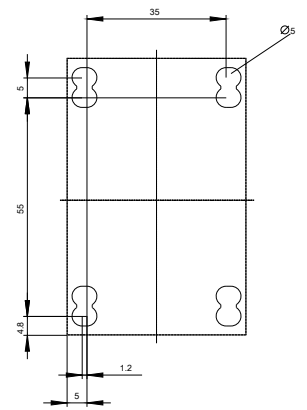
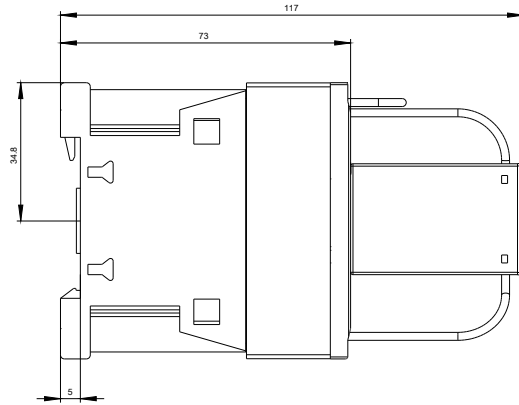
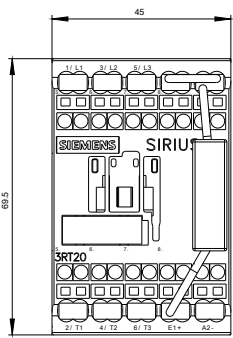

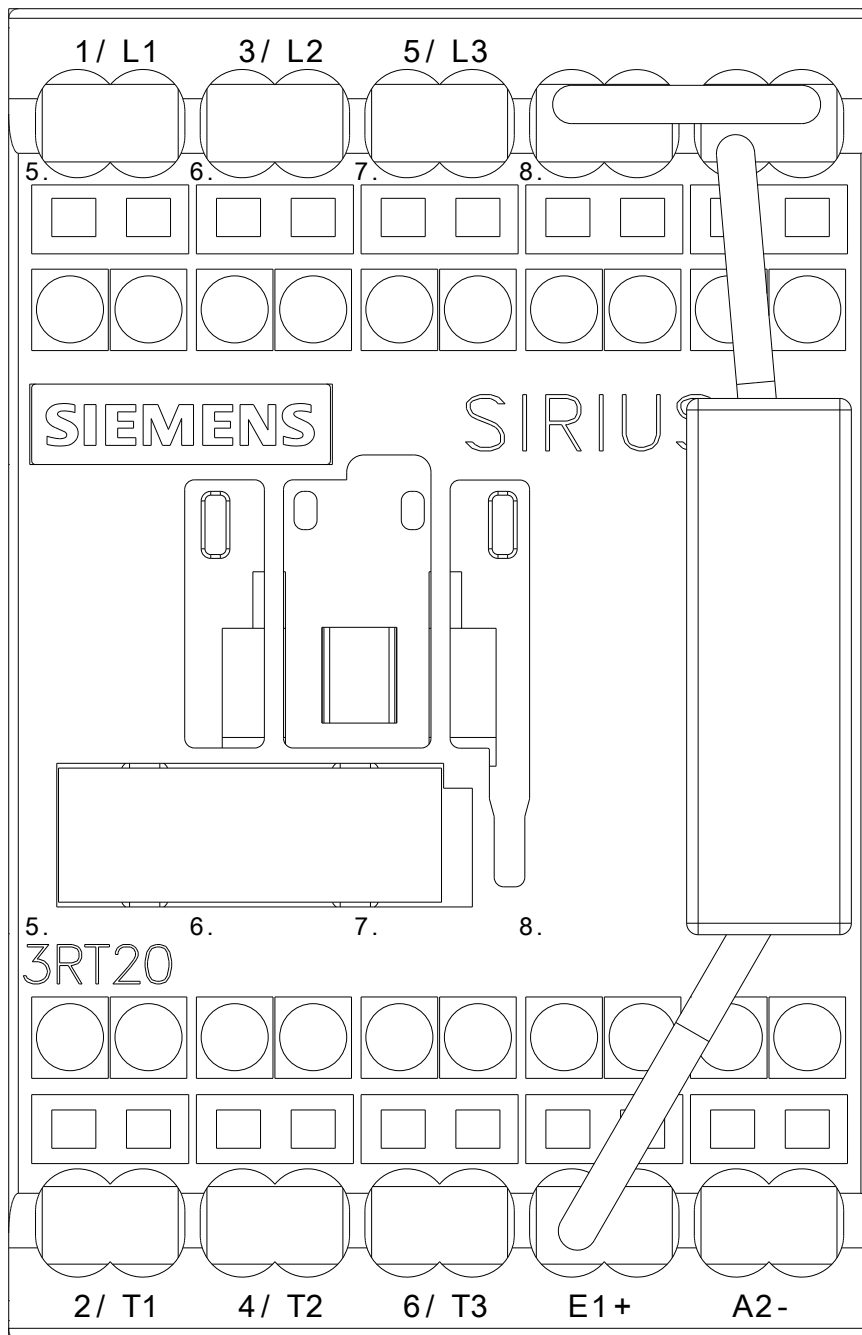

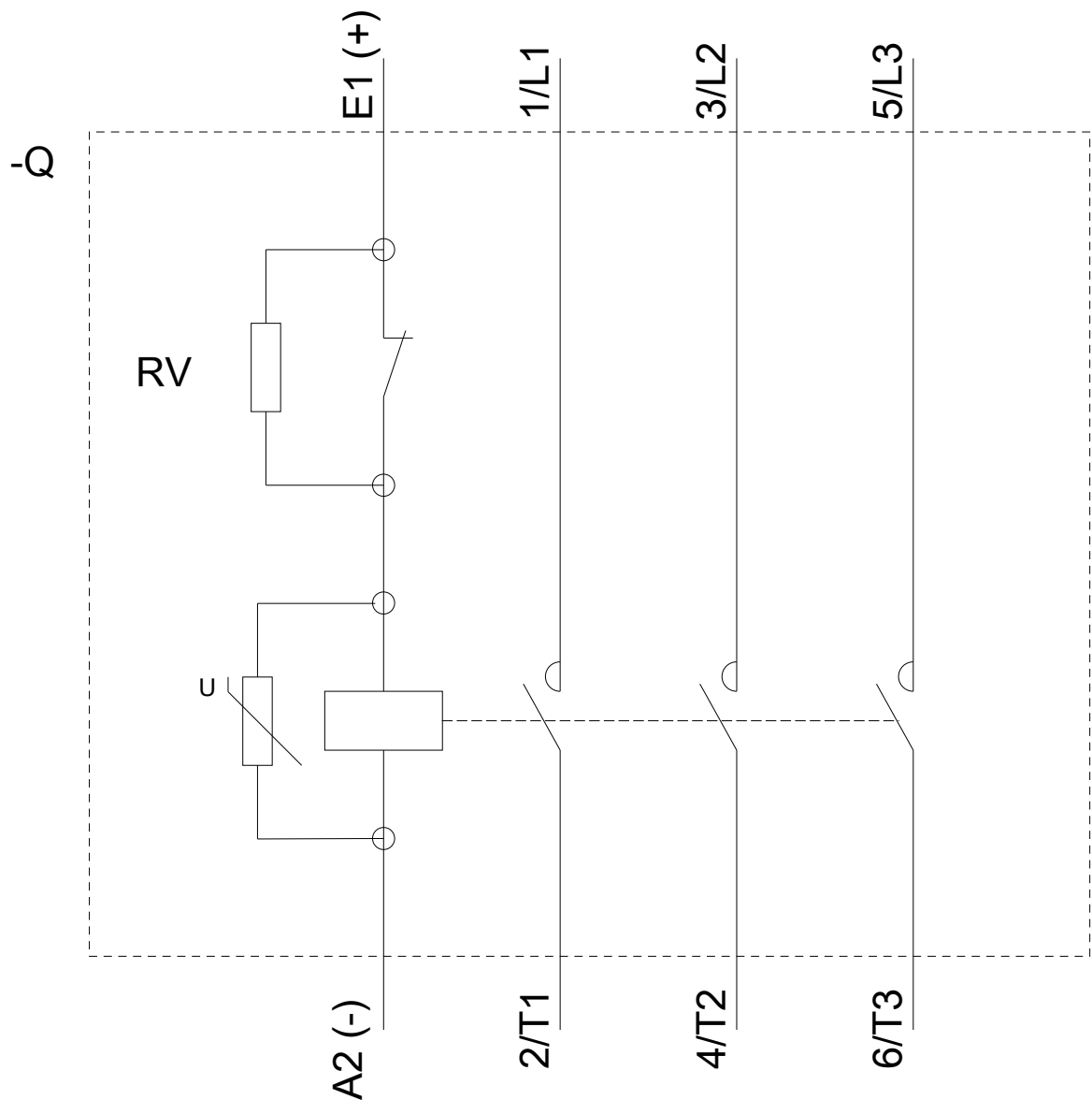

last modified:

09/04/2019