

QC5GB Series

3.2x5.0 2-Pad SMD Quartz Crystal Unit



Features

- Low cost alternative to common seam seal packages
- RoHS compliant by exemption

Applications

- Computer peripherals
- Set-top box, TV sets
- Office automation
- Audio & video

General Specifications

Frequency Range	8.000 to 60.000MHz	
Mode of Oscillation	Fundamental	8.000 to 54.000MHz
	Third Overtone	40.000 to 60.000MHz
Frequency Tolerance at 25°C	±20 to ±50ppm (±30ppm standard)	
Frequency Stability over Temperature Range	See Stability vs. Temperature Table	
Storage Temperature	-55 to +125°C	
Aging per Year	±3ppm	
Load Capacitance C_L	8 to 32pF and Series Resonance	
Shunt Capacitance C_0	5.0pF max.	
Equivalent Series Resistance (ESR)	See ESR Table	
Drive Level	100µW TYP, 300µW max.	
Insulation Resistance ($M\Omega$)	500 at 100Vdc ±15Vdc	

Equivalent Series Resistance (ESR)

Frequency Range - MHz	Ω max.	Mode of Operation
8.000 to 10.000	180	Fundamental
10.000 to 16.000	150	
16.000 to 20.000	100	
20.000 to 30.000	80	
30.000 to 54.000	50	Third Overtone
40.000 to 60.000	120	

Frequency Stability vs. Temperature

Operating Temperature	±20ppm	±30ppm	±50ppm	±100ppm
-20 to +70°C	○	○	○	○
-40 to +85°C	○	●	○	○

● standard ○ available

Mechanical Dimensions

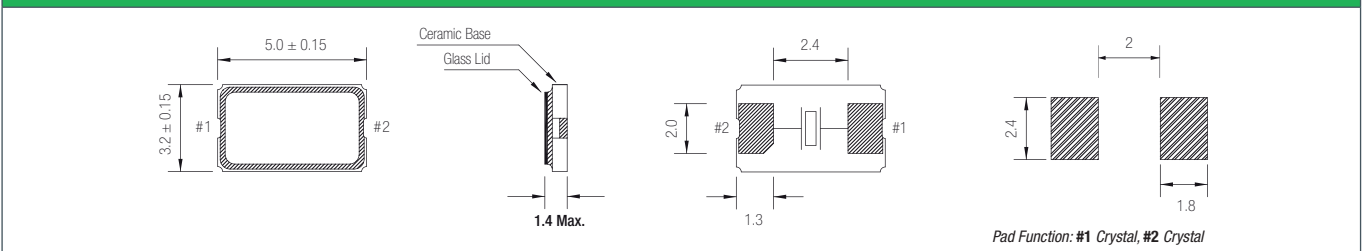

Part Numbering Guide

Qantek Code	Package	Nominal Frequency (in MHz)	Vibration Mode	Load Capacitance	Operating Temperature Range	Frequency Tolerance	Frequency Stability	Packaging
Q = Qantek	C5GB = 3.2x5.0 2-Pad SMD	7 digits including the decimal point (f.i.e. 12.0000)	F = AT-Fund	S = Series 08 = 8pF 12 = 12pF 18 = 18pF 20 = 20pF etc.	A = -20 to +70°C B = -40 to +85°C	2 = ±20ppm 3 = ±30ppm 5 = ±50ppm 0 = ±100ppm	2 = ±20ppm 3 = ±30ppm 5 = ±50ppm 0 = ±100ppm	M = 250pcs Tape&Reel R = 1000pcs Tape&Reel

Example: QC5GB12.0000F12B33R

bold letters = recommended standard specification



QANTEK Technology Corporation

Phone: +1 877-227-0440 (tollfree)

Fax: +1 877-227-0440 (tollfree)

www.qantek.com

info@qantek.com

QC5GB Series

3.2x5.0 2-Pad SMD Quartz Crystal Unit

Tape and Reel Dimensions

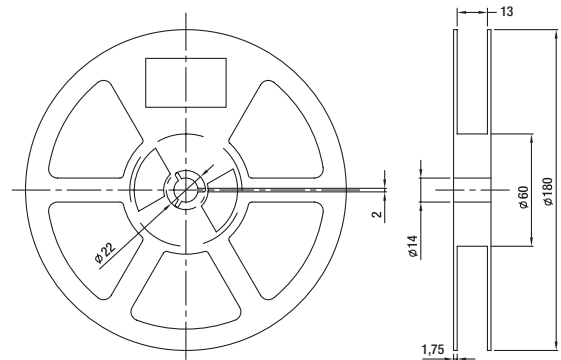
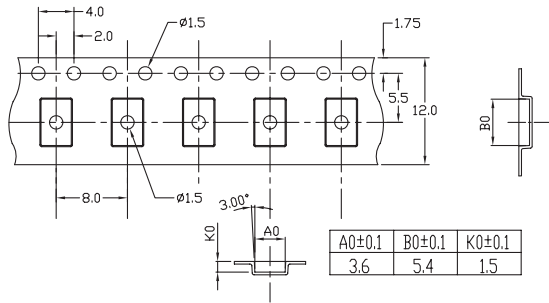

Marking Code Guide

Contains frequency, Qantek manufacturing code, production code (month and year) and load capacitance.

Month Codes

January	A	July	G
February	B	August	H
March	C	September	I
April	D	October	J
May	E	November	K
June	F	December	L

Year Codes

2010	0	2011	1	2012	2
2013	3	2014	4	2015	5

Load Capacitance Code in pF

pF	PN Code	pF	PN Code
12	A	20	F
18	B	22	G
8	C	30	H
10	D	32	I
16	E	S	S

Example: First Line: 12.000 (Frequency) Second Line: QA1A (Qantek - January - 2011 - 12 pF)

Solder Reflow Profile

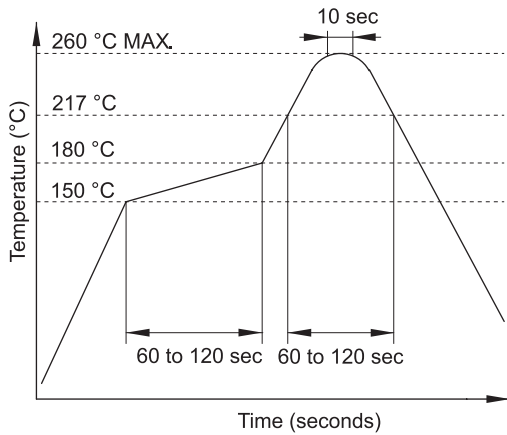

Environmental Specifications

Mechanical Shock	MIL-STD-202, Method 213, C
Vibration	MIL-STD-202, Method 201 & 204
Thermal Cycle	MIL-STD, Method 1010, B
Gross Leak	MIL-STD-202, Method 112
Fine Leak	MIL-STD-202, Method 112

All specifications are subject to change without notice.



QANTEK Technology Corporation
 Phone: +1 877-227-0440 (tollfree)
 Fax: +1 877-227-0440 (tollfree)

www.qantek.com
 info@qantek.com