

RoHS

THIS IS A RoHS COMPLIANT COMPONENT/PRODUCT.

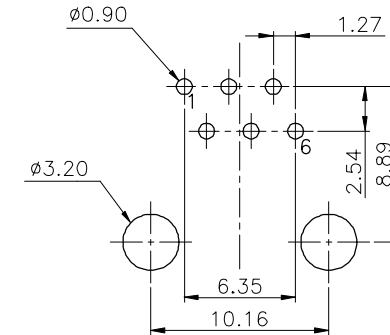
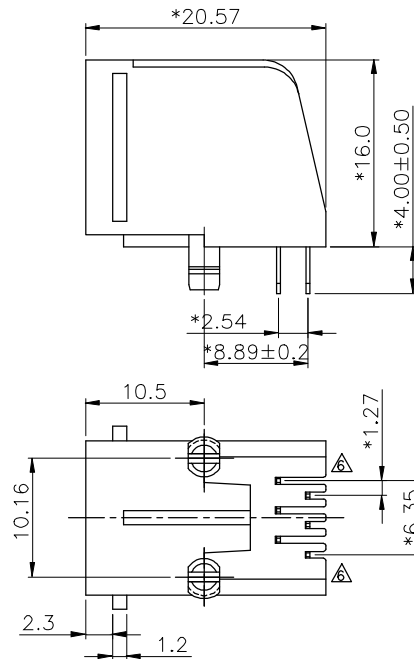
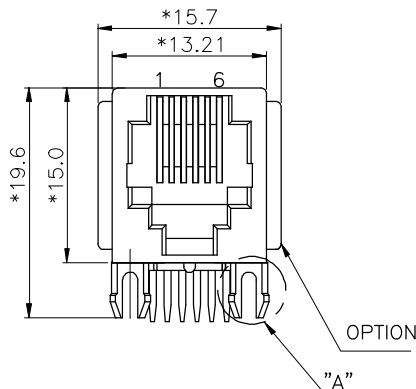
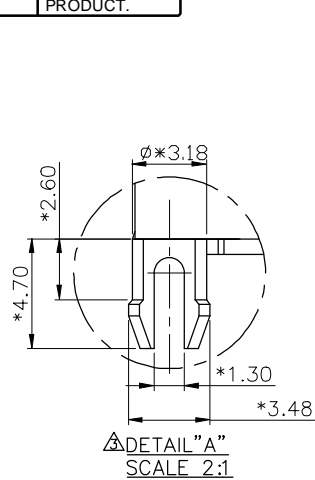

PC Board Layout  
Component Side Shown

NOTES:

ELECTRICAL:

- 1. VOLTAGE RATING : 125 VAC MIN.
- 2. CURRENT RATING : 1.5 AMP MIN.
- 3. CONTACT RESISTANCE : 50 MILLIOHMS MAX.
- 4. INSULATION RESISTANCE: 1000 MEGOHMS MIN @ 500 VDC.
- 5. DIELECTRIC STRENGTH : 1000 VAC 60Hz, 1MIN.

MECHANICAL:

- 1. HOUSING MATERIAL : HIGH TEMP. UL94V-0.
- 2. CONTACT MATERIAL : PHOSPHOR BRONZE t= 0.35 mm.
- 3. PLATING : 1: CONTACT AREA- SELECTIVE GOLD PLATING.  
2: PLATED OVER NICKEL 30u"~80u"FOR ALL  
3: TAILS- PLATED TIN OVER NICKEL.
- 4. OPERATING LIFE : 750 CYCLES MIN.
- 5. PCB RETENTION PRE-SOLDER : 1 LB MIN.
- 6. PCB RETENTION POST-SOLDER: 10 LBS MIN.

ENVIRONMENTAL:

- 1. STORAGE : -40°C TO +85°C.
- 2. OPERATION : -40°C TO +85°C.

MATES WITH MODULAR PLUG CONFORMING TO TIA-1096-A.

ORDERING INFORMATION

PART NUMBER	PRODUCT CODE	CONFIGURATION
3257-0010-01	RJJU-66-127-E7V-010	6U" GOLD PLATING, WITH PANEL STOP, 6P6C
3257-0010-02	RJJU-66-128-E7V-010	6U" GOLD PLATING, WITHOUT PANEL STOP, 6P6C
3257-0010-03	RJJU-64-125-E7V-010	6U" GOLD PLATING, WITH PANEL STOP, 6P4C
3257-0010-04	RJJU-64-126-E7V-010	6U" GOLD PLATING, WITHOUT PANEL STOP, 6P4C
3257-0010-05	RJJU-66-147-E7V-010	30U" GOLD PLATING, WITH PANEL STOP, 6P6C
3257-0010-06	RJJU-66-148-E7V-010	30U" GOLD PLATING, WITHOUT PANEL STOP, 6P6C
3257-0010-07	RJJU-64-145-E7V-010	30U" GOLD PLATING, WITH PANEL STOP, 6P4C
3257-0010-08	RJJU-64-146-E7V-010	30U" GOLD PLATING, WITHOUT PANEL STOP, 6P4C

UL RECOGNIZED - FILE #E465899

△ X1		UPDATE PART NUMBER	MORGAN	022715'
△ X2		UPDATE DRAWING(1)	ARES	113010
△ X1		UPDATE DRAWING(1)	YANG	052810
△ X1		ADD NEW P/N	YANG	030110
△ X1		UPDATE DRAWING(1)	YANG	051809
△ X2		DRAWING MODIFY	YANG	072508
△ X1		UPDATE DRAWING(1)	SAIL	072508
△ X0	0069000	NEW DESIGN	SAIL	030108
MARK	ECN-NO.	REVISION RECORD	DRAWN	DATE

UNLESS OTHERWISE SPECIFIED TOLERANCE		SCALE	CHECKED
Dimension Range	Tolerance	1:1	
X.X	±0.20	UNIT	APPROVED
X.XX	±0.15	mm	
X.XXX	±0.10	SIZE	
ANGLE	±5°	A3	SHEET 1/1
Material/Plated/Notes	NAME		
SEE NOTE	SIDE ENTRY PCB JACK 6P		
Tooling No.	PART NO.	SEE NOTE	REV.
	DOC. NO.		7