

Data sheet | Item number: 852-1200

SFP Module 1000BASE; SX Multi-Mode 850 nm LC; 0.55 km; Extended temperature range; DDM

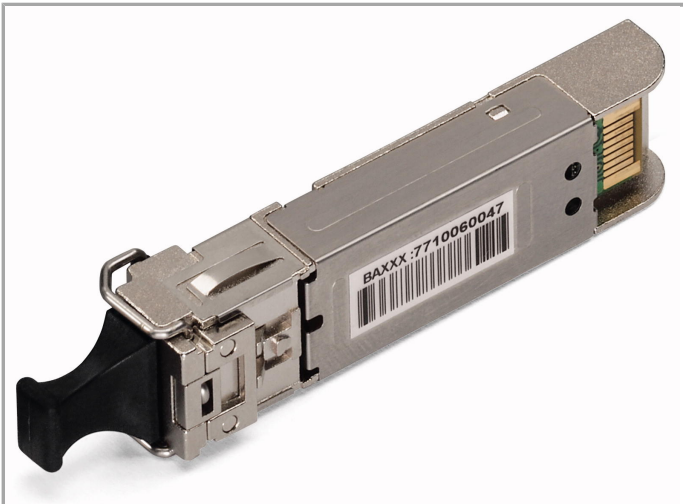

www.wago.com/852-1200



RoHS Compliant



Color:

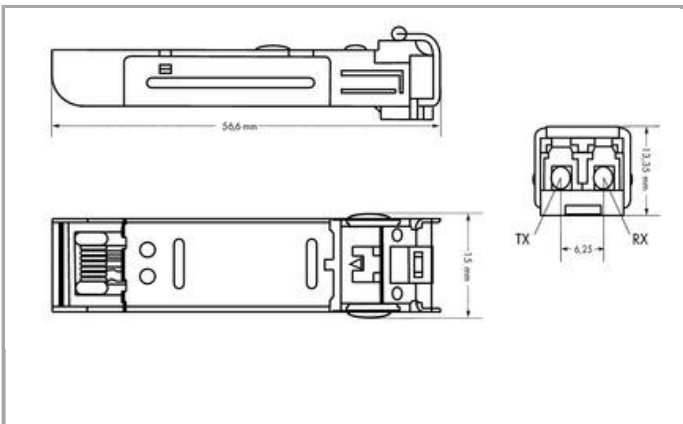
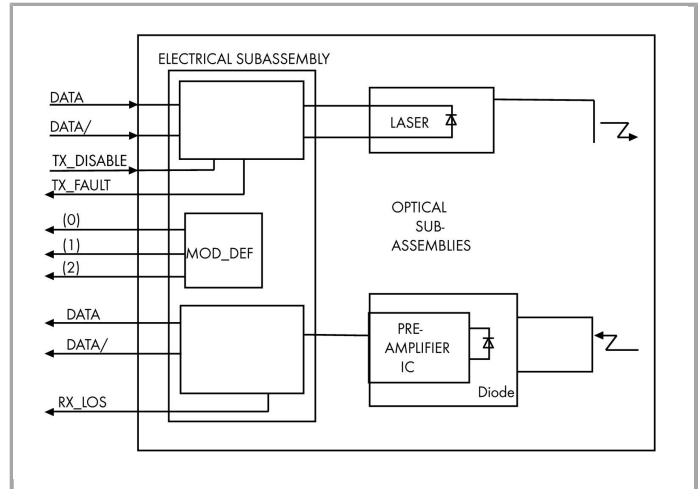

Item description

Features:

- Duplex LC optical connector
- Small Form-Factor Pluggable (SFP) industry-standard design
- Compliant with IEEE802.3z Gigabit ETHERNET Standard
- Differential LVPECL inputs and outputs
- Power supply: 3.3 V



- TTL signal detect indicator
- Hot-pluggable capability

Data

Technical Data

LWL-Fasertyp	Multi-mode
--------------	------------

Connection data

Connection technology: communication/fieldbus	1 x SFP, LC fiber-optic connectors
Anschlussanforderung zulässige Leitungslänge	550 m
Connection requirement (permissible cable type)	Multi-mode fiber 50/125 µm, wavelength 850 nm
Anschlussanforderung zulässige Leitungslänge (2)	300 m
Connection requirement (permissible cable type) (2)	Multimode fiber 62.5/125 µm, wavelength 850 nm

Geometrical Data

Width	13.4 mm / 0.528 inch
Height	13.3 mm / 0.524 inch
Depth	56.6 mm / 2.228 inch

Mechanical data

Weight	40.1 g
Color	silver-colored

Environmental Requirements

Surrounding air (operating) temperature	-40 ... 85 °C
Surrounding air (storage) temperature	-40 ... 85 °C

Commercial data

Country of origin	TW
GTIN	4055143394161
Customs Tariff No.	8517620000

Downloads

Documentation

Bid Text

852-1200	Nov 30, 2016	DOC 26.6 kB	Download
----------	--------------	----------------	----------

Additional Information



Subject to changes.