

Product Data Sheet QG030-303/14

ebmpapst

The engineer's choice



**QG030-303/14
INDEX**

1	General	3
2	Mechanics	3
2.1	General	3
2.2	Connections	3
3	Operating Data	4
3.1	Electrical Operating Data	4
3.2	Electrical Features	4
3.3	Aerodynamics	5
3.4	Sound Data	5
4	Environment.....	5
4.1	General	5
4.2	Climatic Requirements.....	6
4.3	Mechanical Requirements	6
5	Safety	6
5.1	Electrical Safety	6
5.2	Approval Tests	6
6	Reliability.....	7
6.1	General	7

1 General

Fan type	Cross-flow fan	
Rotational direction looking at motor	Clockwise	
Airflow direction	Cross-flow	
Bearing system motor	Ball bearing	
Bearing system rotor	Sleeve bearing	
Mounting position - shaft	Any	

2 Mechanics

2.1 General

Width	365,5 mm	
Height	47,5 mm	
Depth	50,0 mm	
Mass	0,380 kg	
Material spiral with tongue	Metal	
side part material	Plastic	
Impeller material	Metal	
surface protection rotor housing	Elektrophobic coating	

2.2 Connections

Electrical connection	Wires	
Lead wire length	L = 300,0 mm	
Tolerance	+ - 10,0 mm	
Tube length	S = 35,0 mm	
Tolerance	+ - 10,0 mm	
Wire size (AWG)	24	
Insulation diameter	1,55 mm	
Plug	See drawing	
Contact	See drawing	

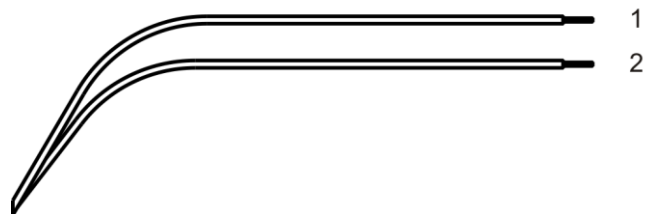

Wire	Color	Operation
1	red	+ UB
2	blue	- GND

3 Operating Data

3.1 Electrical Operating Data

Measurement conditions: Normal air density = 1,2 kg/m³; Temperature 23°C +/- 3°C; Motor axis horizontal; warm-up time before measuring 5 minutes (unless otherwise specified). In the intake and outlet area should not be any solid obstruction within 0,5 m.

$\Delta p = 0$: corresp. to free air flow (see chapter aerodynamics)
 I: corresp. to arithm. mean current value

Features	Condition	Symbol	Values		
Voltage range	$\Delta p = 0$	U	16,0 V		28,0 V
Nominal voltage	$\Delta p = 0$	U_N		24,0 V	
Power consumption Tolerance	$\Delta p = 0$	P		8,7 W +/- 10 %	10,5 W +/- 10 %
Current consumption Tolerance	$\Delta p = 0$	I		360 mA +/- 10 %	380 mA +/- 10 %
Speed Tolerance	$\Delta p = 0$	n	3.000 1/min +/- 7,5 %	4.000 1/min +/- 7,5 %	4.550 1/min +/- 7,5 %

3.2 Electrical Features

Electronic function	None	
Reversed polarity protection	PTC	
Max. residual current at U_{max} reaction time reversed polarity protection	IF 2.800 mA < 15,0 s at $T_u = 23^\circ C$	
Locked rotor protection	PTC	
reaction time locked rotor protection	< 120 s at $T_u = 23^\circ C$	
Locked rotor current at U_{max}	approx. 110 mA according 120 s	

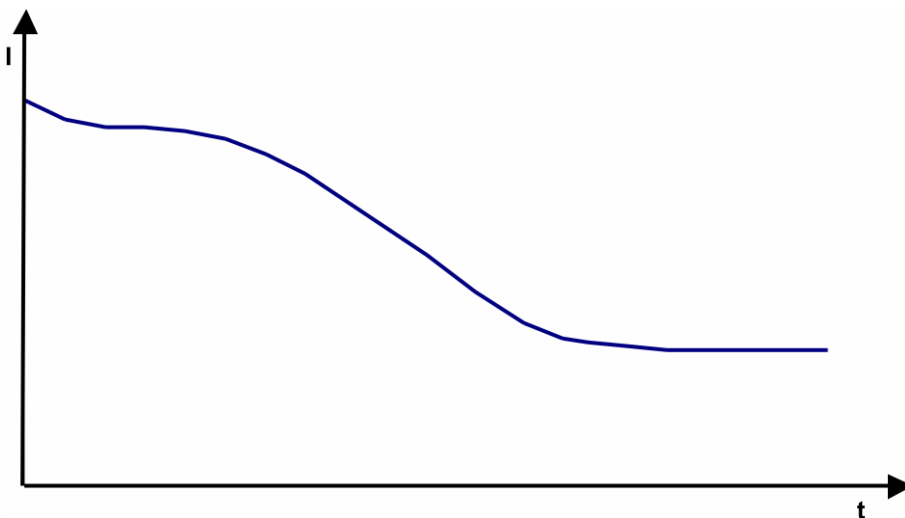

Blower restart possible after a short power shut down.

3.3 Aerodynamics

Measurement conditions: Measured in suction side throttled double-chamber test rig acc. DIN EN ISO 5801 and using a dedicated ebmpapst-setup for cross flow blowers.
 Normal air density = 1,2 kg/m³; Temperature 23°C +/- 3°C;
 In the intake and outlet area should not be any solid obstruction within 0,5 m. Motor shaft horizontal.
 The information is only valid under the specified test conditions and may be changed by the installation conditions. If there are deviations from the standard test conditions, the characteristic values must be checked under the installed conditions.

Operation condition: 4.080 1/min at free air flow

Max. free-air flow ($\Delta p = 0 / \dot{V} = \text{max.}$)	138,0 m ³ /h	
---	-------------------------	--

max. allowable operation point on the fan chart

volumetric flow rate	96,0 m ³ /h	
pressure (Δp)	27 Pa	

The value of the max. allowable operating point is preliminary!

3.4 Sound Data

Measurement conditions: Sound pressure level: 1 meter distance between microphone and the air intake.
 Measured in a semianchoic chamber with a background noise level of L_p(A) < 5 dB(A)
 Measured without dedicated ebmpapst-setup for cross-flow blowers
 For further measurement conditions see chapter aerodynamics.

Operation condition: 4.080 1/min at free air flow

4 Environment

4.1 General

Min. permitted ambient temperature TU min.	-20 °C	
Max. permitted ambient temperature TU max.	60 °C	
Min. permitted storage temperature TL min.	-40 °C	
Max. permitted storage temperature TL max.	80 °C	

4.2 Climatic Requirements

Humidity requirements	humid heat, constant; according to DIN EN 60068-2-78, 14 days	
Water exposure	None	
Dust requirements	None	
Salt fog requirements	None	

Permitted application area:

The product is intended for use in sheltered rooms with controlled temperature and controlled humidity. Directly exposure to water must be avoided.

Pollution degree 1 (according DIN EN 60664-1)

There is either no pollution or it occurs only dry, non-conductive pollution. The pollution has no negative impact.

4.3 Mechanical Requirements

Please require severity levels and specification parameters from the responsible development departments.

5 Safety

5.1 Electrical Safety

Dielectric strength DIN EN 60950 (VDE 0805) and DIN EN 60335 (VDE 0700) A.) Type test Measuring conditions: After 48h of storage at 95% R.H. and 25°C. No arcing or breakdown is allowed! All connections together to ground. B.) Routine test Measuring conditions: At indoor climate. No arcing or breakdown is allowed! All connections together to ground.	500 VAC / 1 Min. 850 VDC / 1 Sec.	
Isolation resistance Measuring conditions: After 48h of storage at 95% R.H. and 25°C measured with U=500 VDC for 1 min.	RI > 10 MOhm	
Clearance / creepage distance	1,0 mm / 1,2 mm	
Protection class	III	

5.2 Approval Tests

CE	EC Declaration of Conformity	Yes
EAC	Eurasian Conformity	Yes
UL	Underwriters Laboratories	Yes / UL507, Electric Fans
VDE	Association for Electrical, Electronic and Information Technologies	Yes / Approval acc. to EN 60950 (VDE 0805) - Information technology equipment
CSA	Canadian Standards Association	Yes / C22.2 No. 113 Fans and Ventilators
CCC	China Compulsory Certification	Not applicable

6 Reliability

6.1 General

Life expectancy L10 at TU = 40 °C	30.000 h	
Life expectancy L10 at TU max.	20.000 h	
Life expectancy L10 acc. to IPC 9591 at TU = 40 °C	50.000 h	

Copying of this document, and using it in whole or in part, without the permission of the copyright holder, are forbidden, with the exception of copying for personal use. All rights are reserved. In the event of the grant of a patent, or the registration of a utility model or design, all rights are reserved.

Schutzvermerk nach DIN ISO 9016 beachten!
Refer to protection notice DIN ISO 9016!

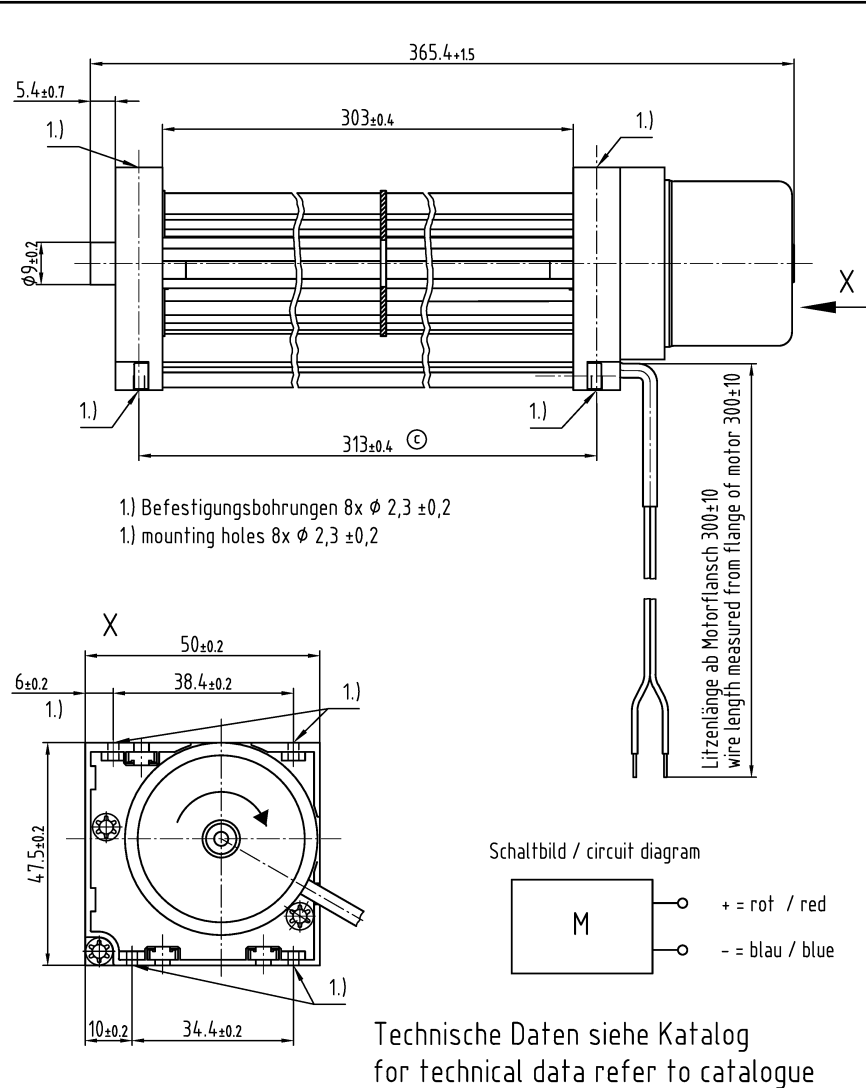

SAP-Status/State		Aend.-Nr./Change-No.		AutoCAD-System-Version		ebmpapst		Werkstoff/Material		Volumen/Volume (mm ³):	
				Date/Date		Name/Name				Gewicht/Mass (g):	
Tolerierung/Tolerances:		Bearb./Drawn		Gepr./Checked		Freig./Released		Artikel/Title			
Allgemeintoleranzen/Gen. tolerances:		ebmpapst		Zchg.-Nr./Drawing-No.:		Ers.f.Zchg./Replaces:					
		ebmpapst		Dokumenttyp/Type of Document		Teildokument (Blatt/Page)		Index/Index		Formal/Size: Masstab/scale	
		ebmpapst St. Georgen GmbH & Co. KG									