

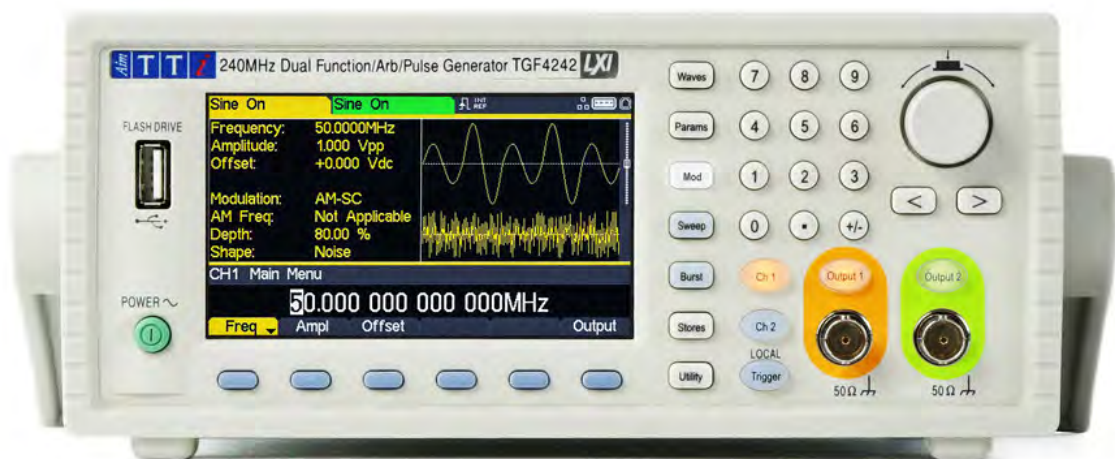

# INSTRUCTION MANUAL

EN



## TGF4000 SERIES

40MHz, 80MHz, 160MHz & 240MHz  
Dual Channel Arbitrary Function Generators

## 1. CONTENTS

<b>1. CONTENTS .....</b>	<b>1</b>
<b>2. Introduction .....</b>	<b>7</b>
Overview .....	7
<b>3. Safety .....</b>	<b>8</b>
Symbols .....	8
Safety notices.....	9
<b>4. Installation .....</b>	<b>10</b>
Mounting .....	10
Ventilation.....	10
Handle/stand .....	10
<b>5. Electrical Requirements.....</b>	<b>11</b>
Mains operating voltage .....	11
Mains lead.....	11
<b>6. Front Panel .....</b>	<b>12</b>
Overview .....	12
<b>7. Rear Panel .....</b>	<b>14</b>
Connections overview .....	14
<b>8. Getting Started.....</b>	<b>16</b>
Using this manual.....	16
Switching on.....	16
Screen layout .....	17
Status line details.....	18
Display options.....	19
Numeric editing .....	20
Editing principles .....	22
Information, warning and error messages .....	23

# 1 - CONTENTS

## Overview

---

General soft-keys .....	24
Maintenance .....	24
Cleaning .....	24
<b>9. Continuous Carrier Waveform Operation .....</b>	<b>25</b>
Waveform selection .....	25
Waveform editing .....	26
Square-wave duty cycle .....	28
Ramp symmetry .....	29
Output .....	30
Arb waves .....	33
Arb arbs .....	35
Sync output .....	39
<b>10. Pulse Generator .....</b>	<b>40</b>
Pulse application .....	40
Pulse width .....	41
Edge times .....	42
Pulse delay .....	43
<b>11. Noise Generator .....</b>	<b>44</b>
Carrier wave noise .....	44
Noise modulation .....	45
<b>12. PRBS Generator .....</b>	<b>46</b>
Carrier wave PRBS .....	46
PRBS modulation .....	47
<b>13. Modulation .....</b>	<b>48</b>
Modulation application .....	48
Amplitude modulation (AM) .....	50
Frequency modulation (FM) .....	54
Phase modulation (PM) .....	58
Amplitude shift keying (ASK) .....	62

# 1 - CONTENTS

## Overview

---

Frequency shift keying (FSK).....	66
Binary phase shift keying (BPSK) .....	70
SUM modulation.....	74
Pulse width modulation (PWM) .....	78
<b>14. Sweep.....</b>	<b>82</b>
Sweep application .....	82
Sweep type .....	84
Sweep time .....	87
Sweep mode .....	87
<b>15. Burst.....</b>	<b>91</b>
Overview .....	91
Burst application.....	92
Burst type.....	93
Burst count.....	94
Burst phase.....	95
Burst triggering.....	96
<b>16. Dual Channel Operation.....</b>	<b>99</b>
Channel selection.....	99
Linked channels .....	100
Coupled operation.....	101
Tracking options.....	103
<b>17. External Counter .....</b>	<b>105</b>
Counter menu .....	105
Counter source.....	106
Counter type.....	107
Measurement .....	107
<b>18. Harmonic Waveforms .....</b>	<b>108</b>
Selecting arb location to store harmonic waveforms .....	108
Editing harmonic waveforms .....	110

# 1 - CONTENTS

Overview

---

<b>19. Utility Menu</b>	<b>113</b>
System	113
Instrument settings	118
I/O	120
Calibration	120
Dual channel operation	120
Help	120
<b>20. Stores Menu</b>	<b>121</b>
Flash drive files and folders	121
Using the stores menu	122
Operations on set-up files	124
Operations on waveform files	129
<b>21. Help Operations</b>	<b>133</b>
Help menu	133
Help topics	134
<b>22. Editing Arbitrary Waveforms</b>	<b>135</b>
Selecting an arbitrary waveform for editing	135
Editing an arbitrary waveform	136
<b>23. Calibration</b>	<b>141</b>
Equipment required	141
Calibration procedure	141
Password control	142
Calibration routine	144
Remote calibration	146
<b>24. Remote operation</b>	<b>147</b>
Overview	147
Address selection	148
Remote/ local operation	149

# 1 - CONTENTS

## Overview

---

USB interface .....	149
Installing USB driver for the first time .....	150
LAN interface .....	151
LAN connection.....	151
GPIB interface.....	155
Status reporting.....	157
<b>25. Remote Commands .....</b>	<b>160</b>
USB/LAN remote command format.....	160
GPIB remote command formats.....	161
Command list .....	162
Channel selection.....	163
Continuous carrier wave commands .....	164
Pulse generator commands .....	165
PRBS generator commands.....	165
Arbitrary waveform commands.....	166
Modulation commands .....	168
Sweep commands.....	170
Burst commands .....	170
External counter commands.....	171
Clock and miscellaneous commands .....	171
Dual-channel function commands .....	171
System and status commands .....	172
Interface management commands.....	174
<b>26. Appendix 1.....</b>	<b>176</b>
Information, warning and error messages.....	176
Error messages.....	176
Warning messages.....	182
Information messages.....	183
Other information messages .....	184

# 1 - CONTENTS

Overview

---

<b>27. Appendix 2.....</b>	<b>185</b>
Factory default settings .....	185
<b>28. Appendix 3.....</b>	<b>188</b>
Waveform manager plus V4.13 .....	188
Arbitrary waveform creation and management software .....	188
<b>29. Specification.....</b>	<b>189</b>

## 2. INTRODUCTION

### Overview

This manual covers all four TGF4000 dual channel generators. Where there are differences in the specification, the limits for the TGF4042 & TGF4082 are shown in square brackets [ ] after the TGF4162 & TGF4242 limits.

These programmable function/arbitrary generators use direct digital synthesis techniques to provide high performance and extensive facilities in a compact instrument. They generate a wide variety of waveforms with high resolution and accuracy.

Sine waves are produced with low distortion to 160MHz/240MHz [40MHz/80MHz]. Square waves have fast rise and fall times at up to 100MHz [25MHz]. Linear ramp waves are produced to 5MHz. Ramp and square waves also have variable symmetry.

The instruments generate high resolution, low jitter, variable edge time pulses to 100MHz [25MHz] with variable period, pulse width, pulse delay, pulse edges and amplitude. Complex custom waveforms can be generated with 16-bit [14-bit] resolution and a sampling rate of 800MSa/s [400MSa/s]. Up to four waveforms can be stored in internal memory. Waveforms can also be generated by the supplied Waveform Manager Plus V4.13 Windows application and downloaded to the instrument via USB, LAN or optional GPIB interfaces or via a USB flash drive.

Front panel operation is straightforward and user friendly with all major parameters shown at all times on the large, bright, colour LCD. All major functions can be accessed with a single key or two. The knob or numeric keypad can be used to adjust frequency, amplitude, offset, and other parameters. Voltage values can be entered directly in Vpp or as high and low levels. Timing parameters can be entered in Hertz (Hz) or seconds.

Internal AM, FM, PM, ASK, FSK, BPSK, SUM\* and PWM modulation make it easy to modulate waveforms without the need for a separate modulation source. Linear and logarithmic sweeps are also built in, with sweep rates selectable from 1  $\mu$ s to 500s. Burst mode operation allows for a user-selected number of cycles at each trigger event.

LAN and USB interfaces are standard and there is full compliance to 1.5 LXI Device Specification 2016.

The instruments use a high stability temperature compensated internal oscillator and the external frequency reference input lets you synchronize to an external 10 MHz frequency standard for even greater accuracy.

\*TGF4162 & TGF4242 only



## 3 - Safety

### Symbols

## 3. SAFETY

### Symbols

This instruction manual contains information and warnings which must be followed by the user to ensure safe operation and to retain the instrument in a safe condition.

The following symbols are displayed on the instrument and throughout the manual, to ensure the safety of the user and the instrument, all information must be read before proceeding.

#### WARNING



Indicates a hazard that, if not avoided, could result in injury or death.

#### CAUTION



Indicates a hazard that could damage the product that may result in loss of important data or invalidation of the warranty.

#### NOTE

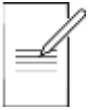

Indicates a helpful tip

#### EXAMPLE



Indicates an example to show further details



Terminal connected to chassis ground.



Mains supply OFF.



Mains supply ON.



Alternating current.

## 3 - Safety

### Safety notices

---

#### Safety notices

This instrument is:

- A safety Class I instrument according to IEC classification and has been designed to meet the requirements of EN61010-1 (Safety Requirements for Electrical Equipment for Measurement, Control and Laboratory Use).
- an Installation Category II instrument intended for operation from a normal single-phase supply.
- tested in accordance with EN61010-1 and has been supplied in a safe condition.
- designed for indoor use in a Pollution Degree 2 environment in the temperature range 5°C to 40°C, 20% - 80% RH (non-condensing).

#### WARNING



Do not operate while condensation is present.

Do not operate outside its rated supply voltages or environmental range.

#### THIS INSTRUMENT MUST BE EARTHED.

Any interruption of the mains earth connector, inside or outside, will make the instrument dangerous. Intentional interruption is prohibited.

Any adjustment, maintenance and repair of the opened instrument under voltage must be avoided.

When connected, terminals may be live and opening the covers or removal of parts (except those that can be accessed by hand) may expose live parts.

To avoid electric shock, or damage to the instrument, never allow water to get inside the case.

If the instrument is clearly defective, has been subject to mechanical damage, excessive moisture or chemical corrosion the safety protection may be impaired and it must be withdrawn from use and returned for checking and repair.

Ensure that only fuses with the required rated current and of the specified type are used for replacement. The use of makeshift fuses and the short-circuiting of fuse holders is prohibited.

This instrument uses a Lithium button cell for non-volatile memory battery back-up; typical life is 5 years. In the event of replacement becoming necessary, replace only with a cell of the correct type, i.e. 3V Li/MnO<sub>2</sub> 20mm button cell type 2032. Exhausted cells must be disposed of carefully in accordance with local regulations; do not cut open, incinerate, expose to temperatures above 60°C or attempt to recharge.

---

#### CAUTION



Do not wet when cleaning, use only a soft dry cloth to clean the screen.

---

## 4 - Installation

### Mounting

---

## 4. INSTALLATION

### Mounting

This instrument is suitable both for bench use and rack mounting.

For rack mounting the protective bezels and handle/stand can be removed such that the instrument can be fitted beside any other standard 2U half-rack instrument in a 19" rack. A suitable 2U 19" rack kit is available from the manufacturers or their overseas agents.

See rack mount instructions for details on how to remove the protective bezel and handle.

### Ventilation

The generator uses a fan fitted to the rear panel. Take care not to restrict the rear air exit or the inlet vents at the front (sides and underneath). In rack-mounted situations allow adequate space around the instrument and/or use a fan tray for forced cooling.

### Handle/stand

The instrument is fitted with a 4-position handle/stand. Pull out both sides of the handle at the case pivot points, to free the position locking pegs, and rotate the handle from the stowed position to the required stand or handle position. Release the sides of the handle to lock it in the new position.

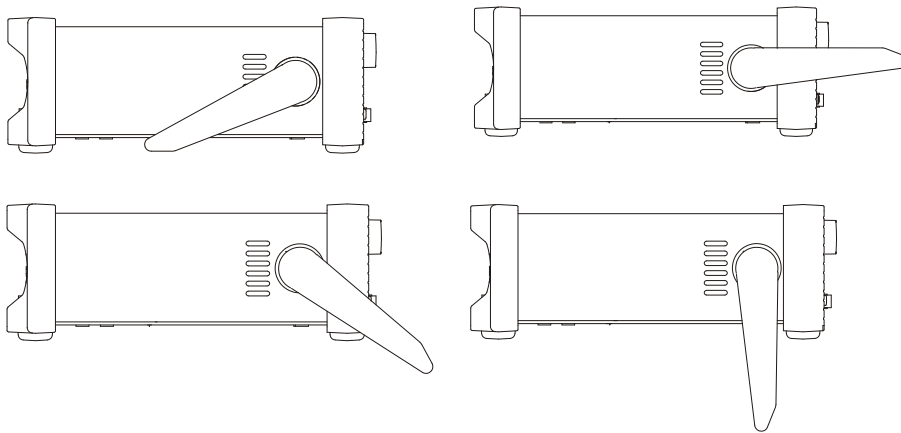

## 5 - Electrical Requirements

Mains operating voltage

---

# 5. ELECTRICAL REQUIREMENTS

### Mains operating voltage

This instrument has a universal input range and will operate from a nominal 115V or 230V mains supply without adjustment. Check that the local supply meets the AC input requirement given in the Specification.

### Mains lead

Connect the instrument to the AC supply using the mains lead provided.

Should a mains plug be required for a different mains outlet socket, a suitably rated and approved mains lead set should be used which is fitted with the required wall plug and an IEC60320 C13 connector for the instrument end.

To determine the minimum current rating of the lead-set for the intended AC supply, refer to the power rating information on the equipment or in the Specification.

### WARNING



THIS INSTRUMENT MUST BE EARTHED.

---

### WARNING



Any interruption of the mains earth conductor inside or outside the instrument will make the instrument dangerous. Intentional interruption is prohibited.

---

# 6. FRONT PANEL

## Overview

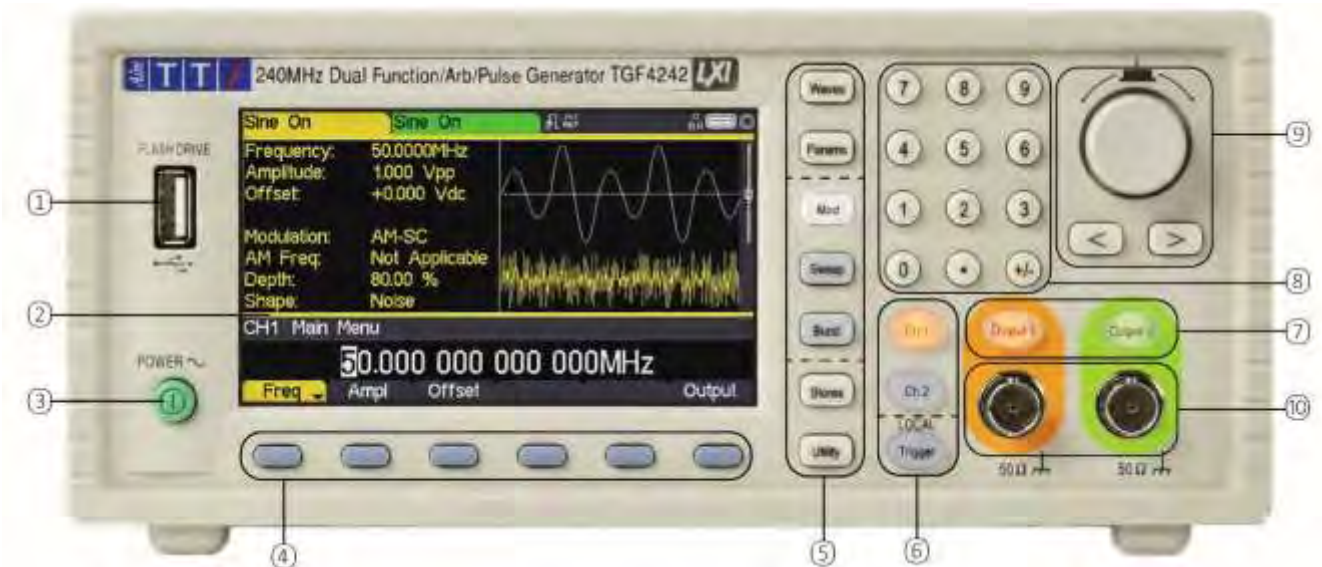

### ① Flash drive

This is a USB Host port for the connection of flash drive which conform to the Mass Storage Class specification. FAT16 or FAT32 filing systems are accepted.

### ② Colour screen

### ③ Power switch

### ④ Soft keys

The function of these keys change as the instrument is operated. The current function is shown on the LCD in a box above each key. An empty box means that the key currently has no function.

### ⑤ Setting keys

WAVES key selects the type of waveform; select from Sine, Square, Ramp, Pulse, Noise and Arb. PARAMS (Parameters) key allows the editing of the waveform parameters.

#### - Mode keys

MOD (modulation), SWEEP and BURST select the operating mode. The selected key becomes illuminated. If all mode keys are unlit the mode will be continuous carrier wave.

#### - Menu keys

STORES key allows access to the built-in storage for waveforms and set-ups and to a connected flash drive.

UTILITY key gives access to menus for a variety of functions such as sync out set-up, power-up parameters, error message settings, frequency counter and dual channel functions.

## 6 - Front Panel

### Overview

---

#### ⑥ Trigger/local key

TRIGGER key is used to issue a manual trigger signal. This key is also used to return to local from remote mode.

#### - Channel Keys

The channel keys select the channel that is to be edited. When Channel 1 is selected the parameter fields text and soft-key background will be orange and the CH1 key will become illuminated, with Channel 2 these fields will change to green and the CH2 key will become illuminated.

#### ⑦ Output keys

The OUTPUT keys simply switch the selected MAIN OUT on or off. There are two OUTPUT keys, one for each channel. The key becomes illuminated when the output is on and the status tab text will change to 'On'.

### NOTE



The display and key colour scheme of channel 1 is orange and channel 2 is green for ease of identification of the currently selected channel.

---

#### ⑧ Numeric keypad

Numeric keys permit direct entry of a value for the parameter currently selected.

#### ⑨ Rotary knob & directional keys

Used during numeric entry. The left and right keys move the edit position left or right and the knob increments or decrements the value of the selected digit.

### NOTE



Press and hold down any key, including soft-keys, for two seconds to access the Help page for that key

---

#### ⑩ Main out (one for each channel)

This is the 50Ω output from main generator. It will provide up to 20V peak-to-peak e.m.f. which will yield 10V peak-to-peak into a matched 50Ω load. To maintain waveform integrity only 50Ω cable should be used and the receiving end should be terminated with a 50Ω load. It can tolerate a short circuit for 60 seconds.

### CAUTION



Do not apply an external voltage to this output.

---

Channel 2 can also be configured to output Channel 1 sync from its MAIN OUT 2 socket. See 'Sync output' for more details.

## 7 - Rear Panel

### Connections overview

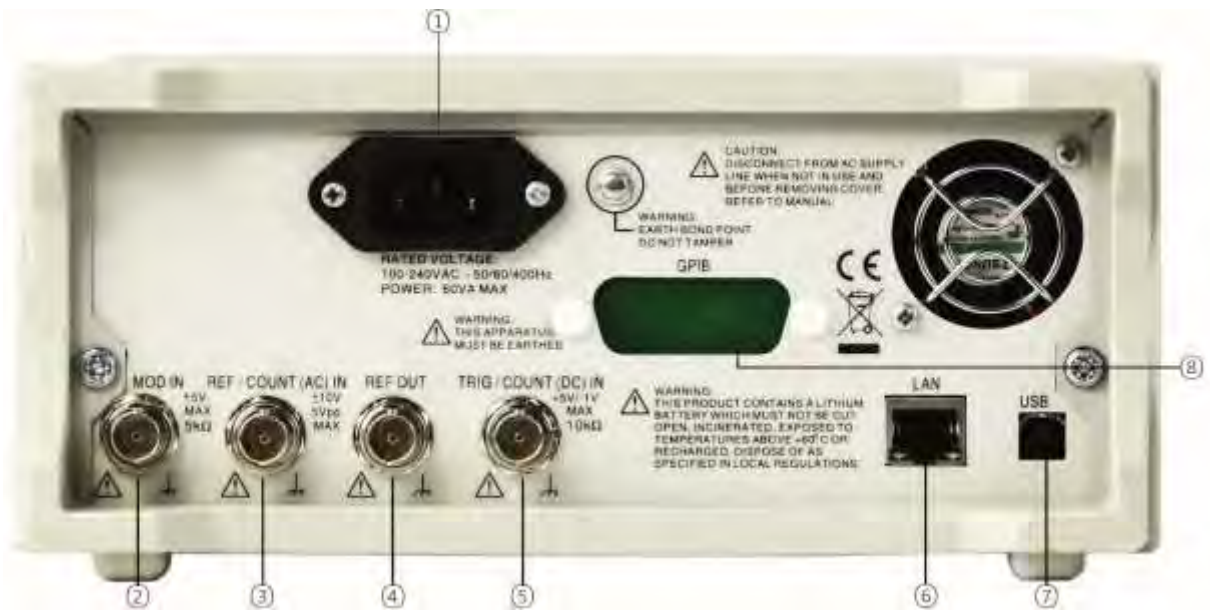

## 7. REAR PANEL

### Connections overview

#### ① AC power inlet

#### ② Mod in

This is the external modulation input socket for AM, FM, PM, SUM or PWM. Full-scale input is  $\pm 2.5V$ , frequency DC to 5MHz.

### CAUTION



Do not apply an external voltage exceeding  $\pm 5V$ .

#### ③ Ref / count (ac) in

Input for an external 10MHz reference clock and AC coupled external frequency measurement. Input range 100mVpp – 5Vpp.

### CAUTION



Do not apply external voltages exceeding  $\pm 10V$  to this signal connection.

#### ④ Ref out

Buffered version of the 10MHz clock currently in use (internal or external). Output level nominally 3V logic from 50 $\Omega$ .

### CAUTION



Do not apply external voltages to this output.

## 7 - Rear Panel

### Connections overview

---

#### ⑤ Trig / count (dc) in

This is the external input for ASK, FSK, BPSK, triggered sweep, gated burst, triggered burst and DC coupled external frequency measurement. Threshold is typically 1.2V and input sensitivity is 100mVpp.

### CAUTION



Do not apply external voltages exceeding + 5V or –1V to this signal connection.

---

#### ⑥ LAN

The LAN interface is designed to meet LXI 1.5 LXI Device Specification 2016.

Remote control using the LAN interface is possible using the TCP/IP Socket protocol. The instrument also contains a basic Web server which provides information on the unit and allows it to be configured. Since it is possible to misconfigure the LAN interface, making it impossible to communicate with the instrument over LAN, a LAN Configuration Initialise (LCI) mechanism is provided via the user interface to reset the unit to the factory default.

Further details are given in the Remote Operation chapter. For more information on LXI standards refer to [www.lxistandard.org](http://www.lxistandard.org)

#### ⑦ USB

The USB port accepts a standard USB cable. If the USB driver has been installed from the website, the Windows plug-and-play function should automatically recognise that the instrument has been connected. See the support page on the website for information on installing the driver on a PC at [www.aimtti.com](http://www.aimtti.com).

Further details are given in 'Remote operation'.

#### ⑧ GPIB (IEEE–488) - optional

The GPIB interface is not isolated; the GPIB signal grounds are connected to the instrument ground.

The implemented subsets are:

- SH1 AH1 T6 TE0 L4 LE0 SR1 RL1 PP1 DC1 DT1 C0 E2

The default GPIB address is 5.

Further details are given in 'Remote operation'



## 8 - Getting Started

Using this manual

---

# 8. GETTING STARTED

## Using this manual

This section is a general introduction to the organisation of the instrument and is intended to be read before using the generator for the first time.

In this manual front panel keys and sockets are shown in capitals, e.g. SWEEP, MAIN OUT; all soft-key labels, entry fields and messages displayed on the LCD are shown in a different type-font, e.g. Offset, Sine.

## Switching on

Connect the instrument to the AC supply using the mains lead provided.

Press the power button, at power up the generator displays a start-up message whilst initialising the application

if an error is encountered the message

**Firmware Update / Battery Fail. Initialised to factory default state.**

will be displayed, see 'Information, warning and error messages'

Loading takes a few seconds, after which the carrier waveform set-up screen is displayed.

### WARNING



To fully disconnect from the AC supply, unplug the mains cord from the back of the instrument or switch off at the AC supply outlet; make sure that the means of disconnection is readily accessible. Disconnect from the AC supply when not in use.

---

## 8 - Getting Started

### Screen layout

#### Screen layout

Once powered up the following screen will appear showing the generator parameters set to their default values, with the MAIN OUT output set to off. Refer to 'Utility Operations' for how to change the power up settings to either those at power down or to the defaults.

Both channel tabs are displayed simultaneously, the selected channel is indicated by a specified coloured tab for easy identification; channel 1 is orange and channel 2 is green. Any channel specific set parameters will always be shown in the specified colour for that channel. System settings will be neutral in white, editing is also shown in white. The default layout shows the details of the selected channel side by side, three screen layout options are available see 'Display options' for further details.

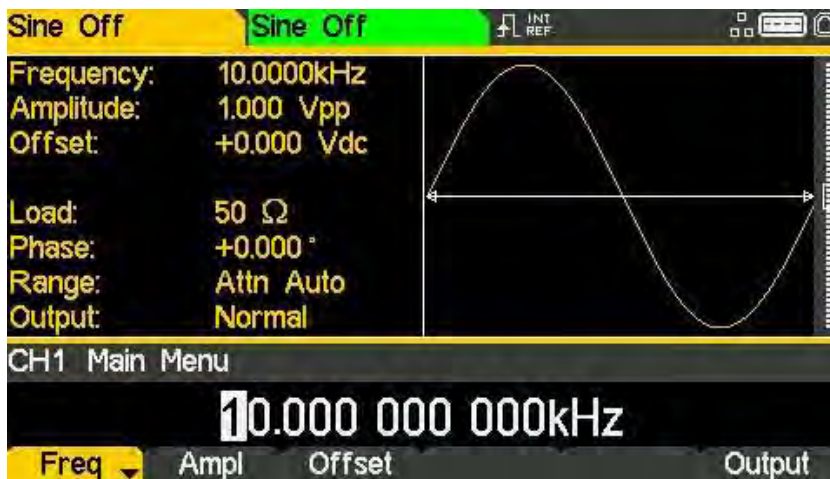

#### Status line

The Status Line indicates the status of the instrument, see 'Status line details' for further information.

#### Parameters boxes

Shows the waveform parameter settings for the selected channel. These always include frequency, amplitude and offset. Additional parameters shown will depend upon the waveform type.

#### Graph box

Shows a representation of the waveform which the instrument is generating on the selected channel. The parameter currently being edited is indicated by arrows.

#### Edit box

Shows the value of the parameter currently being edited on the selected channel. This will be a numeric value or a parameter string.

#### Soft-key labels

Change as editing proceeds.

## 8 - Getting Started

### Status line details

---



#### Status line details

##### Channel tabs

The channel fields contain two types of information, selected waveform (e.g. **Sine**) and signal status (**On** or **Off**). If tracking is selected, the Channel 2 field will be replaced with **Tracking CH1**, if tracking with inversion is selected the field will show **InvTracking CH1**. The only other exception is when calibrating the instrument, the tab will show **Calibrating CH1** or **Calibrating CH2** in the specific channel tab.

##### Clock status

The next field indicates the external clock status.





- If the internal clock is being used,  is displayed alongside **INT REF**.
- If an external clock is being applied or is being used,  appears alongside **EXT REF**.
- If an external valid clock signal is detected (but not used),  **INT REF** is followed by **EXT DET**.
- If the clock source is set to external and a valid external clock signal is not detected, the internal clock will be used by default and displayed followed by **EXT ERR**.

See 'Reference clock source' for further details on clock source.

##### Remote status

When the instrument is under remote control via any interface **REM** will be displayed.

The **LAN** field in the Status Line can show multiple status indications:

-  There is no LAN connection, for example no cable connected. When the system is attempting to connect the icon will flash.
-  Successfully connected with remote control enabled.
-  Connected but remote control is disabled.
-  Unsuccessful attempt to connect.

## 8 - Getting Started

### Display options

#### Display options

Three different screen layout options are available, see 'Utility Menu' for details on how to change the display format.

Layout 1: (Default) Shows both the parameters and the graph for the selected channel.



Layout 2: Shows the parameters for both channels simultaneously.



Layout 3: Shows the graphs for both channels simultaneously.

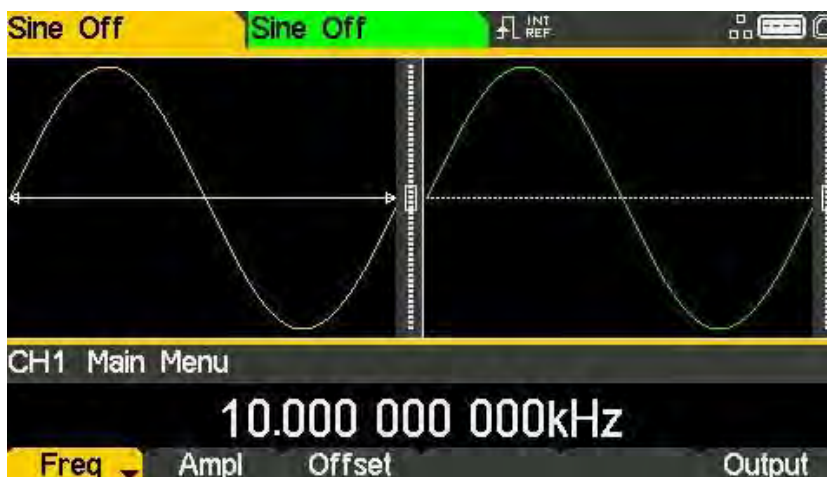

## 8 - Getting Started

### Numeric editing

---

#### Numeric editing

Any numeric parameter may be changed in one of the following ways:

- Enter a new value from the numeric key pad.
- Use the left and right cursor keys to select a digit position then use the knob to increment/decrement the value at that position.

#### Using the numeric key pad

Pressing a number key will erase the current parameter value in the Edit Box and replace it with the current entry. The Soft-key Labels will also change to a list of units applicable to the parameter being edited.

The examples below show frequency units and period (time) units respectively.

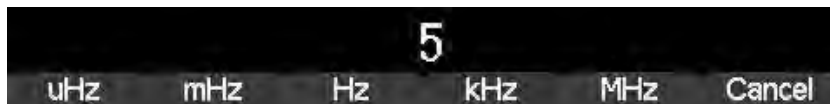

During the numeric data entry, a decimal point and, if appropriate, a sign may be entered. The +/- key is used to alternately change the sign between + and -. The left cursor key may be used to erase the last digit entered. The entry may be cancelled by pressing the **Cancel** key

Once the entry is complete it may be terminated by pressing the soft-key below the required units. The value will be checked and accepted as the new value for the relevant parameter.

## 8 - Getting Started

### Numeric editing

#### Using the knob and cursor keys

#### NOTE



The default settings for the knob is enabled

To disable the knob, press once to hear the click, the cursor will no longer be shown; the knob is now disabled.

To enable the knob, press once, the first numeric parameter will be displayed with an inverse edit cursor over one of the digits. The left and right cursor keys may be used to move the edit cursor to any digit in the value. Values are always shown with enough digits to the right of the decimal point to show the best resolution for the parameter.

#### NOTE



Consecutive presses of the knob will switch between the function being enabled and disabled.

#### EXAMPLE



The right-most digit in a frequency value will be  $\mu\text{Hz}$ . Depending on the actual value, one or more digits to the left of the most significant digit displayed may be zero and will not be shown. It is possible to move the edit cursor into these digit positions and the suppressed zeros will be shown as in the example below.



With the edit cursor positioned at the required digit the knob may be rotated left or right to decrement or increment the digit. As the value passes between 9 and 0 the digits to the left will also change. In this way it is possible to set any legal value for the parameter.

#### NOTE



Changes made by turning the knob are applied immediately to the parameter as long as the value remains legal.

## 8 - Getting Started

### Editing principles

---

### Editing principles

The instrument parameters are edited using the keyboard in conjunction with the Soft-key Labels and the Edit Box.

Generally, the required parameter is selected by pressing WAVES, PARAMS or MOD or soft-keys or a combination of these to show the parameter in the Edit Box. The parameter is then edited using the numeric keys, the soft-keys, the knob and cursor keys or a combination of these.

#### EXAMPLE



- Press the WAVES key to select the waves menu, followed by the **square** soft-key to select the square-wave. Press the **Duty** soft-key to select the square-wave duty cycle parameter which will show in the Edit Box. Now use the numeric keys and Soft-keys to change the parameter as described in 'Numeric editing'.
  - Press the WAVES key to select the waves menu, followed by the **sine** soft-key to select sinewave then press the MOD key to access modulation parameters. Press the **Type** soft-key to select the modulation type parameter. Use the soft-keys to select the required type from **AM, FM, PM, ASK, FSK, SUM** or **BPSK**. Press the **Done** soft-key to exit the menu. Press the **On/Off** soft-key to turn on modulation.
  - Press the WAVES key to select the waves menu, followed by the **arb** soft-key to select arbitrary waveforms, followed by the **Waves** soft-key. Now select one of the built-in waveforms from the soft-keys. The Edit Box will show the loaded waveform.
-

## 8 - Getting Started

Information, warning and error messages

### Information, warning and error messages

Three classes of message are displayed on the screen in a Pop-up Box:

INFORMATION messages are shown to inform the user of actions that are being taken, for example:

**Please wait... the current settings are being saved**

WARNING messages are shown when the entered setting causes some change which the user might not necessarily expect. For example:

With square-wave selected at 1MHz and a Duty cycle of 25%, select sinewave and change the frequency to 100MHz. Then select square-wave again and the message **Square symmetry set to default 50%** will pop up.

ERROR messages are shown when an illegal setting is attempted, most generally a number outside the range of values permitted. In this case the entry is rejected and the parameter setting is left unchanged.

#### EXAMPLE



- Entering a frequency of 10MHz for a ramp waveform. The error message "**Frequency / Period invalid for Ramp. Frequency Upper limit 5.00MHz. Period lower limit 200.00ns**" is shown.
- Entering a sinewave amplitude of 25Vpp. The error message "**Invalid entry. Amplitude Upper limit [VALUE]**" is shown
- Entering a DC offset of 20V on a sinewave with an amplitude of 1.000 Vpp. The error message "**Invalid entry. Offset Upper limit [VALUE]**" is shown.

The messages are shown on the display for approximately four seconds; however, pressing any key will immediately remove the Pop-up Box and execute the function of the key which is pressed. The last two messages can be viewed again by pressing the UTILITY, then **Help** key and selecting the first or second entries from the Help menu, see 'Help Operations' for more information.

Each warning and error message is accompanied by a beep. The beep may be enabled or disabled in the UTILITY menu, under **System**. See 'Beep state' for more information.



## 8 - Getting Started

### General soft-keys

#### General soft-keys

↶ often appears when editing and it always perform the same function. The ↶ key is known as BACK and will move the soft-key labels and Edit Box up one level in the hierarchy.

The ➡ soft-key indicates that there are more options to show, press this key to show them.



In this case there is one more list of options which will show when the ➡ soft-key is pressed. One more press of the ➡ soft-key will show the first list again.

The Done key will move back to the top level in the hierarchy.

**Freq** ▼ When a soft key features a triangle, successive presses will give further options.

#### Maintenance

The Manufacturers or their agents overseas will provide a repair service for any unit developing a fault. Where owners wish to undertake their own maintenance work, this should only be done by skilled personnel in conjunction with the service guide which may be obtained directly from the Manufacturers or their agents overseas.

#### Cleaning

If the instrument requires cleaning, use a cloth that is only lightly dampened with water or a mild detergent.

### WARNING



To avoid electric shock, or damage to the instrument, never allow water to get inside the case. To avoid damage to the case never clean with solvents.

## 9 - Continuous Carrier Waveform Operation

Waveform selection

# 9. CONTINUOUS CARRIER WAVEFORM OPERATION

Seven types of carrier waveform can be generated:

- Sine
- Square
- Ramp
- Pulse
- Noise
- PRBS
- Arbitrary

This section deals with the use of the instrument as a simple function /arbitrary generator, i.e. generating sine, square, ramp and arbitrary waveforms continuously with no modulation.

### Waveform selection

Pressing the WAVES key followed by any of the carrier waveform soft-keys, **sine**, **square**, **ramp**, **pulse**, **noise** or **arb**, will immediately switch to that waveform making it available at the MAIN OUT connector if the output is on, indicated by the OUTPUT key becoming illuminated. If the output is not on press the OUTPUT key to turn output on.

The screen below shows the effect of pressing the WAVES key followed by the **ramp** soft-key.



The orange channel 1 indicator tab shows that the waveform is set to **ramp** and the Graph Box has changed to show the ramp waveform.

## 9 - Continuous Carrier Waveform Operation

Waveform editing

### Waveform editing

#### Frequency

Pressing the **Freq** soft-key while it is highlighted will change the label to **Period** and time units will be used to edit the parameter.

#### NOTE



The upper frequency limits vary for the different waveform types; see 'Specification' for details.

#### Amplitude

Press **WAVES** key to return to waves menu and select a **sine** wave. Pressing the **Ampl** soft-key shows the amplitude parameter in the Edit Box and the Graph Box changes to show that amplitude is being edited.



The amplitude can be set in terms of peak-to-peak Volts (Vpp) from the **Ampl** soft key, to set high and low levels see 'High level and low level'. The level can be set assuming that the output is either open-circuit or terminated.

#### NOTE



The actual generator output impedance is always 50Ω; the displayed amplitude values for other load values take this into account.

## 9 - Continuous Carrier Waveform Operation

### Waveform editing

#### DC offset

Pressing the **Offset** soft-key shows the dc offset parameter in the Edit Box and the Graph Box changes to show that offset is being edited.



#### High level and low level

The instrument allows the amplitude and offset parameters to be entered in terms of high level and low level. Pressing either the **Ampl** or **Offset** soft-key while it is highlighted will switch the mode from amplitude/offset to high/low level. To return to amplitude/offset mode press the highlighted **HiLvl** or **LoLvl** soft-key.

With high/low level mode selected the edit box shows the parameter, the Parameters Box shows High Level and Low Level in place of Amplitude and Offset and the Graph Box changes to show the parameter which is being edited.



## 9 - Continuous Carrier Waveform Operation

### Square-wave duty cycle

#### Square-wave duty cycle

With square-wave as the selected waveform, pressing the **Duty** soft-key shows the duty cycle parameter in the Edit Box and the Graph Box changes to show that duty cycle is being edited.



## 9 - Continuous Carrier Waveform Operation

### Ramp symmetry

#### Ramp symmetry

With ramp as the selected waveform pressing the **Symm** soft-key shows the symmetry parameter in the Edit Box. The Ramp waveform in the Graph Box will change to show a representation of the shape when the symmetry is being edited.



#### NOTE



To produce a triangle waveform set the symmetry to 50%.

## 9 - Continuous Carrier Waveform Operation

### Output

#### Output

Pressing the **Output** soft-key allows access to control the output parameters.

#### Phase

In the **Output** menu, press the **Phase** soft-key to change the start phase of the waveform. The phase parameter will appear in the Edit Box.



The setting may be used to determine the phase difference between the two channels or between channel 1 waveform and its carrier sync. The channels may be phase aligned by pressing the **Align** soft-key. The Phase parameter is also used to set Burst Phase.

#### Output type

Pressing the **Type** soft-key on the **Output** menu will alternate between **Normal** and **Inverse**.



**Inverse** will invert the carrier waveform at the MAIN OUT connector. The output is set to **Inverted** in the parameters box and the carrier waveform in the Graph Box will be inverted.

## 9 - Continuous Carrier Waveform Operation

### Output

#### Range

Pressing the **Range** soft-key will alternate between **Auto** and **Hold**.

The instrument, by default, is in **Auto** mode; it auto-ranges in 6dB attenuator steps (i.e. 'range' maximums of 10Vpp, 5Vpp, 2.5Vpp, etc., into 50Ω), With range set to **Auto** the amplifiers and attenuators will switch automatically for optimal performance, providing best amplitude resolution, noise and accuracy.



Selecting **Hold** mode disables auto-ranging; the attenuator setting is fixed for the unit's maximum amplitude. This can be useful in eliminating momentary disruptions in the output waveform in Auto mode caused by the switching of the attenuators while changing the amplitude. However, waveform quality will start to deteriorate at lower amplitudes.



With range set to **Hold** a fixed attenuator setting is used for all amplitude settings. The **Range** field in the Parameters Box will show **Attn Hold** while range is held.



## 9 - Continuous Carrier Waveform Operation

### Output

#### Load

Pressing the **Load** soft-key will show the current load value in the Edit Box.

This is the value that is assumed to be loading at the instrument MAIN OUT connector. The value is used to calculate the actual values of amplitude and dc offset.



### NOTE



The output impedance of the instrument MAIN OUT connector is fixed at 50 $\Omega$ .

Pressing the **Load** soft-key will alternate between **High-Z** and the last value entered. With **High-Z** selected the load impedance will be assumed infinite and '**High-z**' will appear in the parameters box.

Press the **Done** soft-key to return to the top-level waveform menu.



## 9 - Continuous Carrier Waveform Operation

Arb waves

### Arb waves

The instrument contains a total of sixteen arbitrary waveforms, Twelve fixed:

- Exponential Rise (ExpRis)
- Exponential Fall (ExpFal)
- Logarithmic Rise (LogRis)
- Logarithmic Fall (LogFal)
- Sinc (Sinc)
- Gaussian (Gauss)
- Lorentz (Lrntz)
- D- Lorentz (DLrntz)
- HaverSine (HvrSin)
- Cardiac (Crdiac)
- DC (DC)
- Triangle (Triang)
- Four user defined.
- There are more waveforms available on the website: [www.aimtti.com](http://www.aimtti.com)

With **Arb** as the selected waveform, pressing the **Waves** soft-key switches to the **Arb Waves** menu. The name of the selected arb is shown in the Edit Box and the Graph Box shows the arb waveform.



The soft-keys allow access to all of the arbitrary waveforms in the instrument.

To select an arbitrary waveform, press the appropriate soft-key.

## 9 - Continuous Carrier Waveform Operation

### Arb waves

Pressing the DC soft-key followed by the **Done** key, produces a dc only waveform at the MAIN OUT connector.

The screen shows the result of selecting an Arb waveform with DC as the selected waveform.



The orange channel 1 status line shows DC in the Waveform field, the Graph Box shows a DC waveform with DC offset arrows and the Edit Box contains the DC voltage menu.

## 9 - Continuous Carrier Waveform Operation

Arb arbs

### Arb arbs

With arb as the selected waveform, pressing the Arbs soft-key switches to the Arb/Arbs menu.



Pressing the Load soft-key opens the load sub-menu.



The four soft-keys **User1** through **User4** allows direct access to the user-defined arbitrary waveforms in the instrument. To select an arbitrary waveform, press the appropriate soft-key. Press the **Done** soft-key to return to the top-level **Arb** menu.

## 9 - Continuous Carrier Waveform Operation

Arb arbs

### Editing arbs

Pressing the Arbs soft-key and then **Edit** soft-key opens the edit sub-menu.

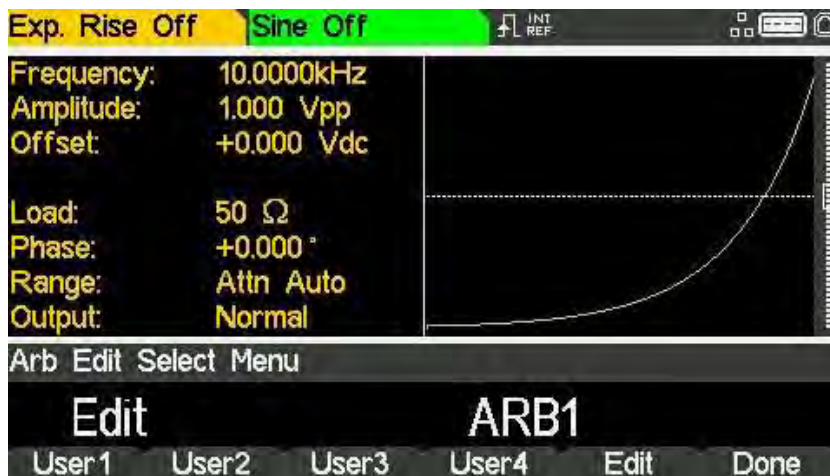

The instrument is capable of performing simple editing of stored arbitrary waveforms. For more complex editing and creation of waveforms see the Waveform Manager Plus V4.13 Windows application, available on the website: [www.aimtti.com](http://www.aimtti.com)

The name of the arb selected for editing is shown in the edit box. To select an arbitrary waveform for editing press the appropriate soft-key.

The selected waveform is edited by pressing the **Edit** soft-key. For a full description of the editing capabilities see 'Editing Arbitrary Waveforms'. Press the **Done** soft-key to return to the top-level **Arb** menu.

## 9 - Continuous Carrier Waveform Operation

Arb arbs

### Harmonics (TGF4162 & TGF4242 only)

Pressing the Arbs soft-key and then Hrmonic soft-key opens the harmonic waveform sub-menu.



The instrument is capable of creating waveforms by the addition of sine wave harmonics. Up to 16 harmonics can be used, chosen from up to the 50<sup>th</sup> order. The amplitude and phase can be individually set for each harmonic. Harmonic waveforms can also be created or edited in the Waveform Manager Plus V4.13 Windows application supplied on the website: [www.aimtti.com](http://www.aimtti.com)

The created harmonic waveform will be stored in one of the four user-defined arbitrary waveform locations. The name of the arb selected for storing the harmonic waveform is shown in the Edit Box. To select an arbitrary waveform location for storing the harmonic waveform press the appropriate soft-key. For a full description of the harmonic waveform capabilities see 'Harmonic Waveforms'.

### NOTE



Any previous waveform stored in the same location will be erased.

Press the **Done** soft-key to return to the top-level **Arb** menu.

## 9 - Continuous Carrier Waveform Operation

Arb arbs

### Filter (TGF4162 & TGF4242 only)

Pressing the Arbs soft-key and then Filter soft-key opens the arbitrary waveform filter menu.



The instrument includes two filters to smooth transitions between points as arbitrary waveforms are generated. The Step filter has a nearly ideal step response, but with more roll-off in its frequency response than the Normal filter. The Normal filter has a wide, flat frequency response, but its step response exhibits overshoot and ringing.

The current filter band-width is shown in the Edit Box. To select between the two available filters, press the appropriate soft-key.

Press the **Done** soft-key to return to the top-level **Arb** menu.

## 9 - Continuous Carrier Waveform Operation

### Sync output

---

### Sync output

Channel 2 can be configured to output Channel 1 sync from its MAIN OUT 2 socket. Sync is a multi-function output which is automatically selected based on the current instrument set-up. Alternatively, user can choose Sync to always be carrier referenced, to output the currently used trigger signal or turn it off.

- **Carrier Sync:** A square wave at the same frequency as the carrier waveform. Available for all waveforms except Noise.
- **Modulation Sync:** A square-wave at the same frequency as the internal modulation waveform with a duty of 50%. Not available for external modulation.
- **Sweep Sync:** A square wave at the sweep rate.
- **Burst Sync:** A square wave coincident with a burst output.
- **Trigger:** A buffered version of the Trigger signal.

The selection of the signals themselves and configuration of channel 2 as channel 1 sync is discussed in the 'Utility Menu'. By default, the automatic selection is enabled which will choose the most relevant output for the instrument set-up. However, it is possible to override the automatic setting. See 'Utility Menu' for more information.



## 10 - Pulse Generator

Pulse application

# 10. PULSE GENERATOR

## Pulse application

The pulse generator can produce a wide range of pulses with adjustable period, width, and edge speed. It may also be set in Gated or Burst mode or modulated using PWM; for more information see 'Modulation' section and 'Burst' section.

Each channel has an independent pulse generator. These may be set to any combination of period, width and modulation or burst. However, when the channels are linked by one of the dual-channel functions there are some restrictions between the parameters of the two channels; see the Dual-Channel Operations in 'Specification' for details.

Pressing the WAVES key followed by the **Pulse** soft-key will switch to the pulse waveform. The screen below shows the effect of selecting pulse.



The PlsFrq soft-key allows setting of the pulse frequency. Pressing the key while it is highlighted will change it to PlsPer and the pulse period may be entered. The pulse generator uses its own value for pulse frequency/pulse period. Changing it will not affect the frequency/period value of the other carrier waveforms.



Amplitude and dc offset are adjusted in the same way as for sine waves and they may also be set in terms of high level and low level.

Pressing the Duty/Width soft-key allows the pulse duty or width to be set.

# 10 - Pulse Generator

## Pulse width

### Pulse width

Pressing the **Duty** soft-key while it is highlighted changes the editable parameter to **Width**, the **Width** parameter is shown in the Edit Box in terms of time (ns,  $\mu$ s, ms, or s) The value represents the time from the mid-point of the rising edge to the mid-point of the falling edge, the Graph Box changes to show that width is being edited and the value is shown in the parameters box.



Pressing the **Width** soft-key while it is highlighted changes the editable parameters to **Duty**, the **Duty** parameter is shown in the Edit Box as the width of the pulse as a percentage of the period to a maximum resolution of 0.01%, the Graph Box changes to show that width is being edited and the value is shown in the parameters box.



# 10 - Pulse Generator

## Edge times

### Edge times

To amend edge times, press the **More** soft-key to show more options and select **Edge**.



The edge time represents the time between the 10% and 90% points on the pulse edges. Rise time and fall time can be coupled or adjusted independently.

Pressing the **Mode** soft-key toggles between **Independent** or **Coupled** mode. When **Coupled** mode is selected the **Edge** soft key is available, this edits both rise and fall parameters together. When selecting **Independent** mode, **Edge** is replaced by with two soft-keys; **Rise** and **Fall** and these parameters can be edited independently. The graph box changes to show the parameters being edited.



The parameters box will show **Rise** and **Fall** at all times, the values will change depending on whether coupled or independent mode has been selected.

# 10 - Pulse Generator

## Pulse delay

### Pulse delay

Pressing the Delay soft-key shows the delay parameter in the Edit Box, the Graph Box changes to show that delay is being edited and the Delay setting is shown in the parameters box.



The Graph box shows the delay parameter between the arrows.

Delay can be specified in terms of time (ns, us, ms or s) Changing the delay causes the start of the pulse to be delayed with respect to the sync pulse available at the SYNC OUT connector.

The delay also adds a delay between the trigger signal and the pulse output during burst modes. See 'Burst' for more details of Burst and Gate modes. The delay also changes the relative timings of the pulses in dual channel modes.

# 11 - Noise Generator

Carrier wave noise

## 11. NOISE GENERATOR

The instrument contains a wide-band Gaussian white noise generator for each channel which may be used in the following ways:

- As the main output from the carrier wave generator
- As a modulating waveform
- Added as a percentage to the current output waveform using SUM modulation.

These options are described in the following sections. In dual channel mode there are some restrictions on Noise; see Dual-Channel Operations in 'Specification' for details.

### Carrier wave noise

Pressing the WAVES key, followed by the Noise soft-key will switch to the Noise/PBRS function and show the screen below.



It is possible to edit these parameters in terms of high level and low level by pressing the **Ampl** key.

Pressing the **Source** soft-key shows the following and allows either noise or the PRBS function to be selected. Press **Noise** to select the Noise function. Press **Done** to exit the **Source** menu.



# 11 - Noise Generator

## Noise modulation

### High level and low level

The instrument allows the amplitude and offset parameters to be entered in terms of high level and low level. Pressing either the **Ampl** or **Offset** soft-key while it is highlighted will switch the mode from amplitude/offset to high/low level. To return to amplitude/offset mode press the highlighted **HiLvl** or **LoLvl** soft-key.



With high/low level mode selected the edit box shows the parameter, the Parameters Box shows High Level and Low Level in place of Amplitude and Offset and the Graph Box changes to show the parameter which is being edited

### Noise modulation

Noise may be used as a modulation shape in the same way as sine or ramp etc. Noise can also be used as a carrier wave for amplitude and sum modulation and for amplitude shift keying. See 'Modulation' for more information.

## 12 - PRBS Generator

Carrier wave PRBS

# 12. PRBS GENERATOR

(TGF4162 & TGF4242 only)

The instrument contains a PRBS (Pseudo Random Binary Sequence) generator for each channel which may be used in the following ways:

- As the main output from the carrier wave generator
- As a modulating waveform

These options are described in the following sections. In dual channel mode there are some restrictions on PRBS; see Dual-Channel Operations in 'Specification' for details.

### Carrier wave PRBS

Pressing the WAVES key, followed by the **Noise** soft-key will switch to the Noise/PBRS function. Pressing the **Source** soft-key shows the following. Press **PRBS** to select the PRBS function. Press **Done** to exit the Source menu.



Press the **Type** soft-key to set PRBS type. The soft-keys PN7, PN9, PN11, PN15, PN20, PN23, PN29 and PN31 set the number of bits used to generate the PRBS.



Choosing a PRBS type and pressing the **Done** soft-key shows the PRBS edit menu.

## 12 - PRBS Generator

### PRBS modulation

Use the BitRate soft-key to set the rate at which the PRBS generator is clocked.



Use the Ampl and Offset soft-keys to set these parameters as for any other carrier wave.



### PRBS modulation

PRBS may be modulated or used as a modulation shape in the same way as sine or ramp, etc. See 'Modulation' for more information.



# 13 - Modulation

Modulation application

## 13. MODULATION

### Modulation application

The instrument can apply nine types of modulation:

- Amplitude Modulation (AM)
- Amplitude Modulation – Suppressed Carrier (AM-SC)
- Frequency Modulation (FM)
- Phase Modulation (PM)
- Amplitude Shift Keying (ASK)
- Frequency Shift Keying (FSK)
- Binary Phase Shift Keying (BPSK)
- Pulse Width Modulation (PWM)
- SUM (Carrier plus Modulating signal)

#### NOTE



Only one modulation type may be applied at any one time.

#### NOTE



Not all modulation types can be applied to a selected carrier waveform.

Modulation type	Carrier waveform							Internal waveform shapes
	Sine	Square	Ramp	Pulse	Noise	Arb	PBRs*	
AM (AM-SC)	•	•	•	•	•	•	•	Sine, Square, Positive Ramp, Negative Ramp, Triangle, Gaussian Noise, DC, Sinc, Exponential Rise/ Fall, Logarithmic Rise/ Fall, Haversine, Gaussian, Lorentz, D-Lorentz, Cardiac & User Defined Arb
FM	•	•	•			•		
PM	•	•	•			•		
ASK	•	•	•	•	•	•	•	Square
FSK	•	•	•			•		
BPSK	•	•	•			•		
PWM				•				Sine, Square, Positive Ramp, Negative Ramp, Triangle, Gaussian Noise, DC, Sinc, Exponential Rise/ Fall, Logarithmic Rise/ Fall, Haversine, Gaussian, Lorentz, D-Lorentz, Cardiac & User Defined Arb
SUM*	•	•	•	•	•	•	•	

\*TGF4162 & TGF4242 only

## 13 - Modulation

### Modulation application

Pressing the MOD key will allow access to control the modulation parameters. Pressing the On/Off soft-key will apply the currently selected modulation to the currently selected carrier waveform and the MOD key will become illuminated.

The screen below shows the effect of pressing the On/Off soft-key when Sine is the selected waveform, Internal is the selected (default) source and the selected modulation type is AM.



The Parameters Box on the right-hand side now shows **AM** in the **Modulation** field and the current modulation parameters of **AM Freq**, **Depth** and **Shape**. The Graph Box shows the modulating waveform below a representation of the modulated carrier waveform.

To change the carrier waveform parameters, press the WAVES key, followed by the waveform required. Notice that **AM** still shows in the **Modulation** field of the Parameters Box and the MOD key still glows, indicating that modulation is still active. To return to the modulation menu to edit the modulation parameters press the MOD key again. To turn off modulation press the On/Off soft-key in the modulation menu.

### NOTE



When modulation is enabled any sweep or burst applications will be disabled.

# 13 - Modulation

## Amplitude modulation (AM)

### Amplitude modulation (AM)

To select amplitude modulation, press the MOD key to access the modulation menu and then press the Type soft-key to show the display below.

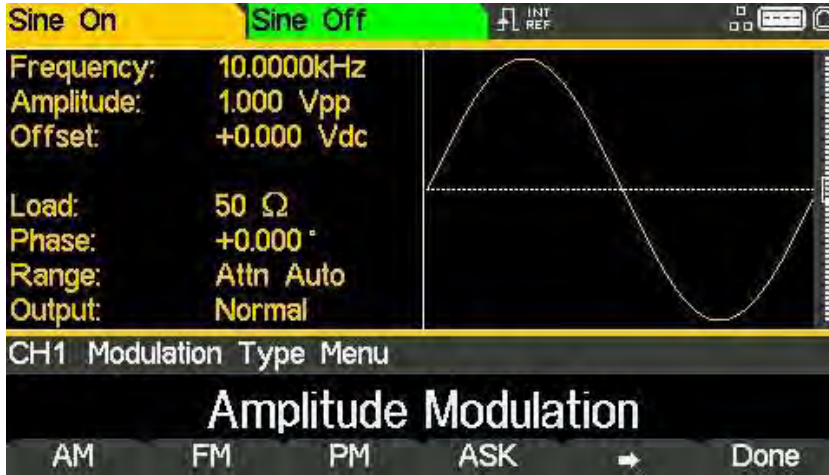

The soft-keys present all of the available modulation types.

If amplitude modulation is not already selected press the **AM** soft-key to access the amplitude modulation sub-menu.

#### Carrier waveform suppression

The instrument supports two types of amplitude modulation, 'normal' and double sideband suppressed carrier. In suppressed carrier amplitude modulation, the carrier is not present unless the modulating signal has an amplitude greater than zero.

Select from the two types of amplitude modulation and then press **↕** soft-key.

Press the **Done** key to return to the top-level modulation menu.

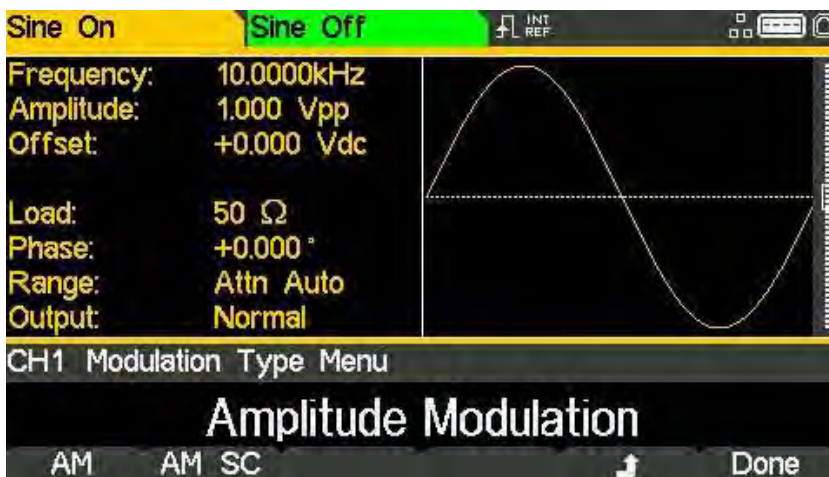

Press **On/Off** soft-key to apply the selected modulation.

# 13 - Modulation

## Amplitude modulation (AM)

### Modulation source

To select the modulation source, press the **Source** soft-key, the options are **Internal** or **External**.

**Internal** will use the waveform specified in the shape parameter and the Graph Box will show that shape as the modulating waveform.

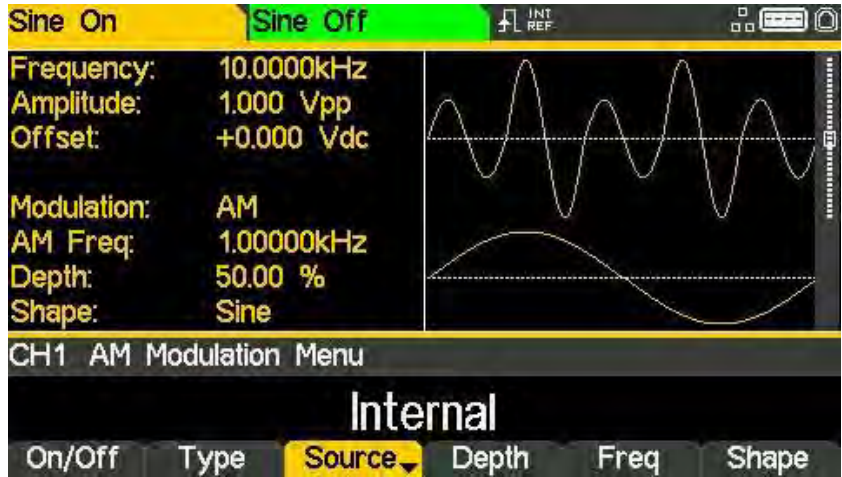

**External** will use the signal present at the MOD IN connector and the **Freq** and **Shape** parameters will no longer be editable. The Graph Box will always show a sinewave as the modulating waveform if the source is set to **External**.

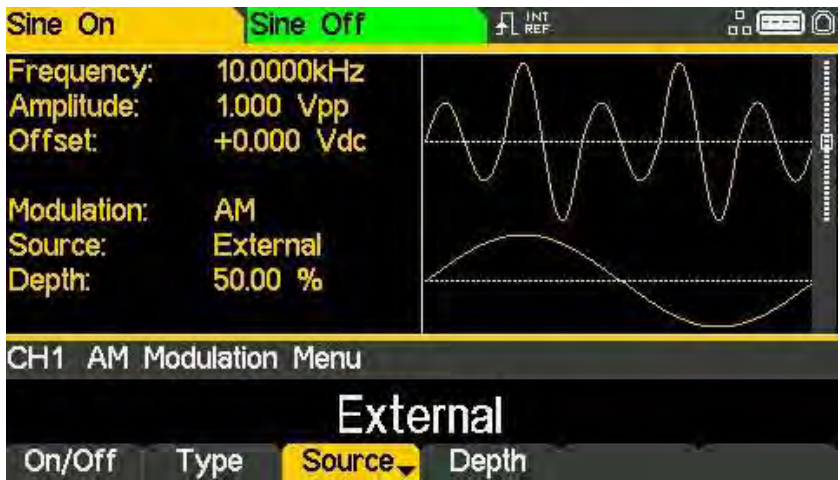

# 13 - Modulation

## Amplitude modulation (AM)

### Modulation depth

To set the modulation depth press the **Depth** soft-key. The Depth parameter will appear in the Edit Box and the modulating waveform in the Graph Box will show that depth is being edited.



### Modulation frequency

To set the modulation frequency press the **Freq** soft-key. The frequency parameter will appear in the Edit Box and the modulating waveform in the Graph Box will show that frequency is being edited.



# 13 - Modulation

## Amplitude modulation (AM)

### Modulation shape

To set the modulation shape press the **Shape** soft-key. The currently selected shape will appear in the Edit Box and the soft-keys will change to a list of shapes available.



Select the modulation shape required by pressing the appropriate key then press the **Done** soft-key to return to the top-level modulation menu.

All the parameters for amplitude modulation are now set.

# 13 - Modulation

## Frequency modulation (FM)

### Frequency modulation (FM)

To select frequency modulation, press the MOD key to access the modulation menu and then press the Type soft-key to show the display below.

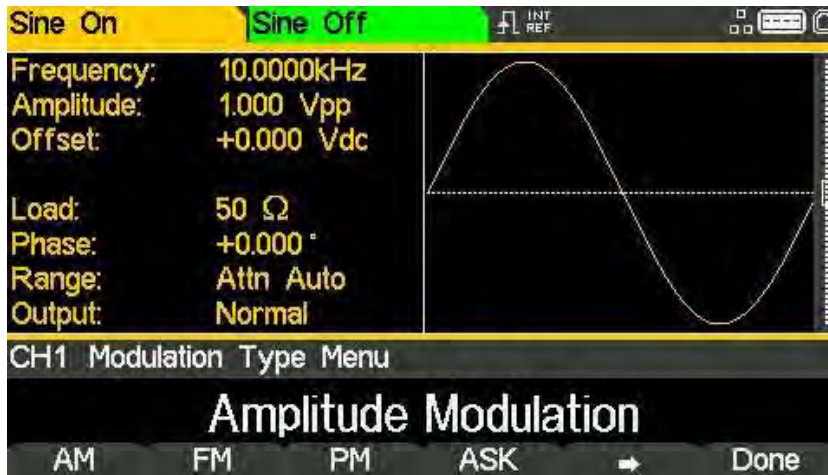

The soft-keys present all of the available modulation types.

If frequency modulation is not already selected press the FM soft-key followed by the Done key to return to the top-level modulation menu.

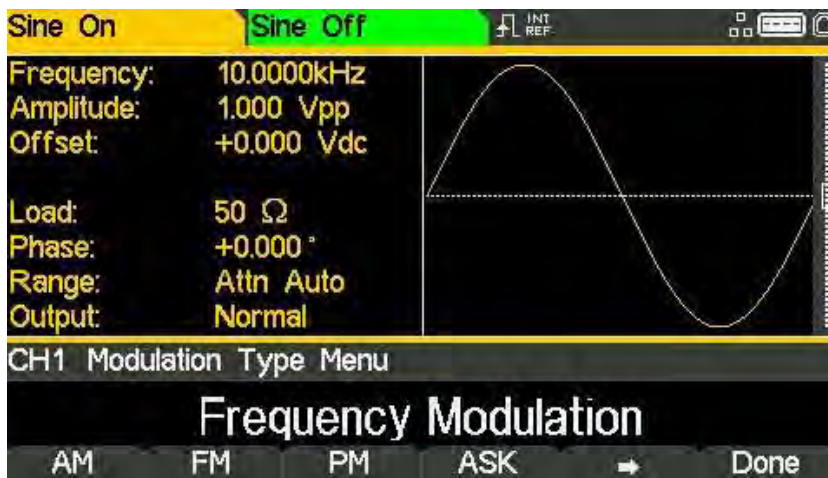

Press On/Off soft-key to apply the selected modulation.

# 13 - Modulation

## Frequency modulation (FM)

### Modulation source

To select the modulation source, press the Source soft-key, the options are **Internal** or **External**.

**Internal** will use the waveform specified in the shape parameter and the Graph Box will show that shape as the modulating waveform.

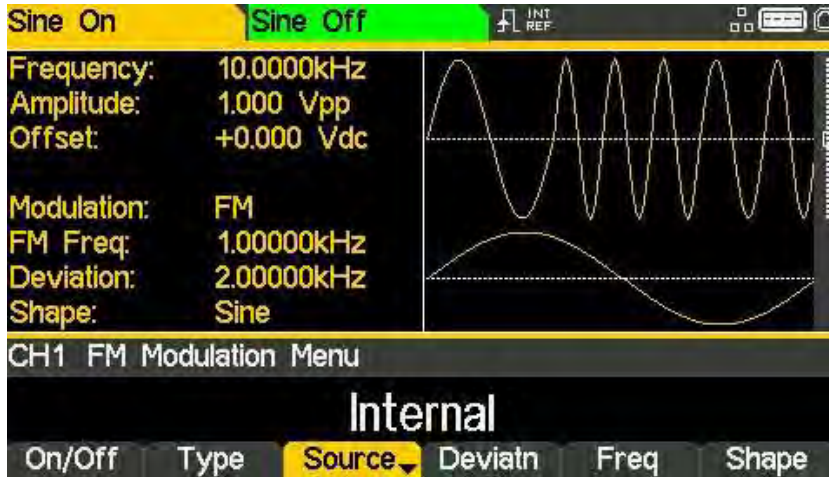

**External** will use the signal present at the MOD IN connector and the **Freq** and **Shape** parameters will no longer be editable. The Graph Box will always show a sinewave as the modulating waveform if the source is set to **External**.

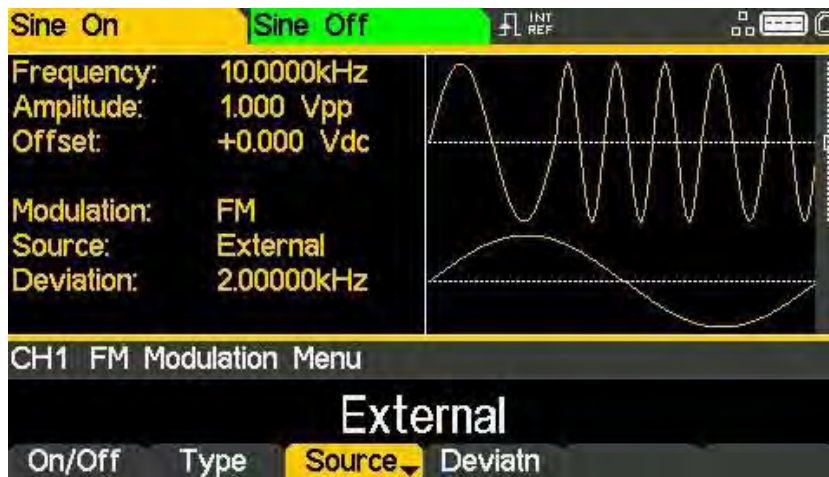



# 13 - Modulation

## Frequency modulation (FM)

### Frequency deviation

To set the frequency deviation press the **Deviatn** soft-key. The deviation parameter will appear in the Edit Box and the modulating waveform in the Graph Box will show that deviation is being edited.



### Modulation frequency

To set the modulation frequency press the **Freq** soft-key. The frequency parameter will appear in the Edit Box and the modulating waveform in the Graph Box will show that frequency is being edited.



## 13 - Modulation

### Frequency modulation (FM)

#### Modulation shape

To set the modulation shape press the **Shape** soft-key. The currently selected shape will appear in the Edit Box and the soft-keys will change to a list of shapes available.

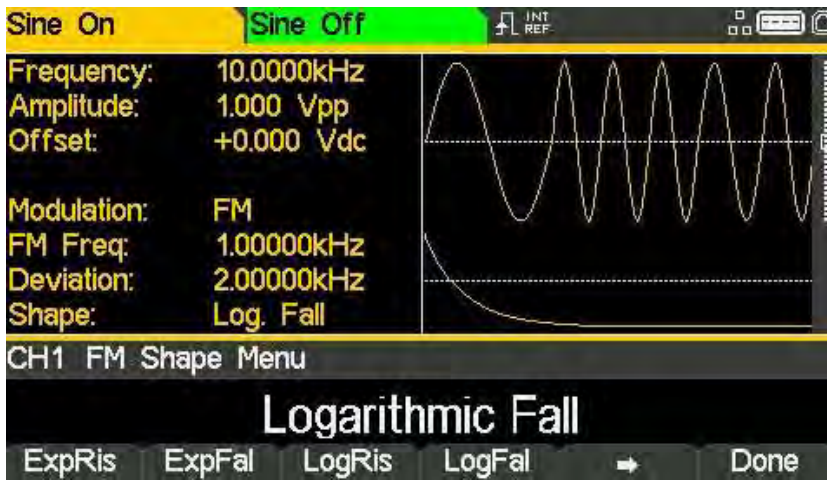

Select the modulation shape required by pressing the appropriate key then press the **Done** soft-key to return to the top-level modulation menu.

All the parameters for frequency modulation are now set.

# 13 - Modulation

## Phase modulation (PM)

### Phase modulation (PM)

To select phase modulation, press the MOD key to access the modulation menu and then press the Type soft-key to show the display below.



The soft-keys present all of the available modulation types.

If phase modulation is not already selected press the PM soft-key followed by the Done key to return to the top-level modulation menu.



Press On/Off soft-key to apply the selected modulation.

# 13 - Modulation

## Phase modulation (PM)

### Modulation source

To select the modulation source, press the **Source** soft-key, the options are **Internal** or **External**.

**Internal** will use the waveform specified in the shape parameter and the Graph Box will show that shape as the modulating waveform.

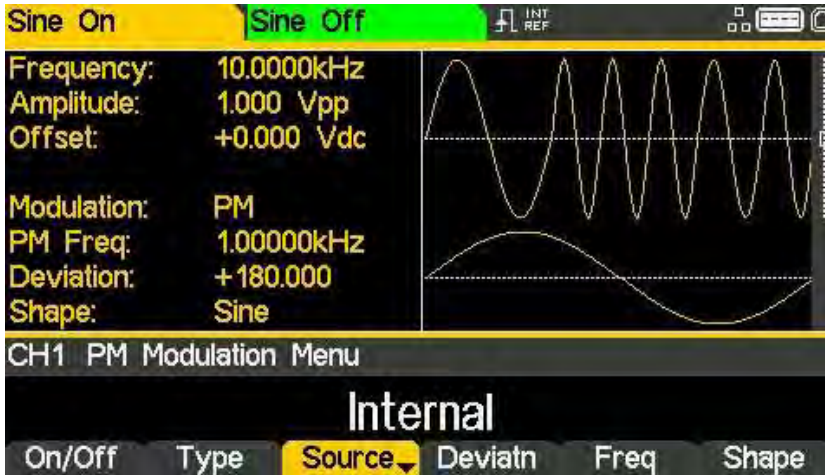

**External** will use the signal present at the MOD IN connector and the **Freq** and **Shape** parameters will no longer be editable. The Graph Box will always show a sinewave as the modulating waveform if the source is set to External.

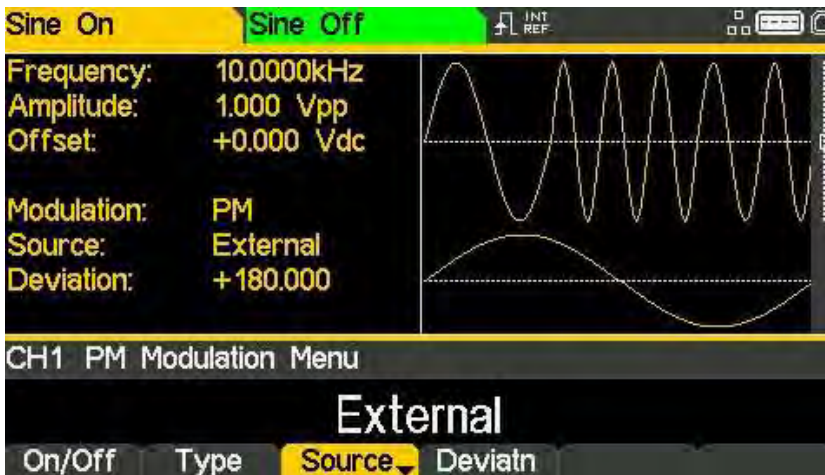

# 13 - Modulation

## Phase modulation (PM)

### Phase deviation

To set the phase deviation press the **Deviatn** soft-key. The deviation parameter will appear in the Edit Box and the modulating waveform in the Graph Box will show that deviation is being edited.

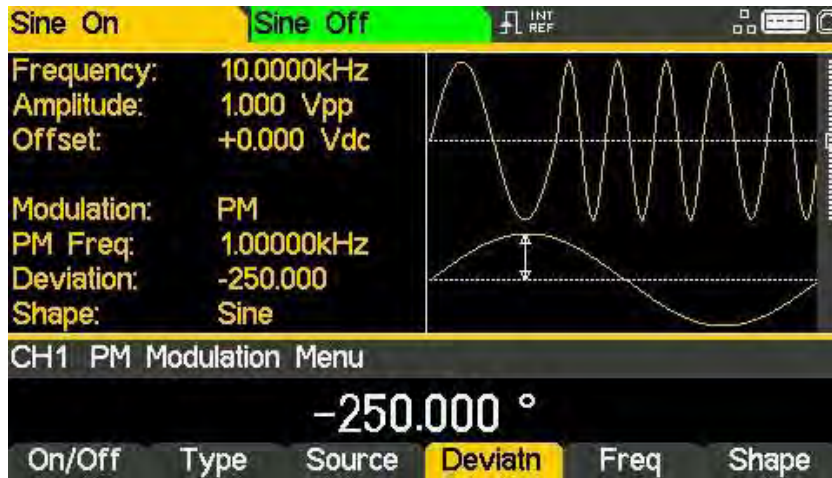

### Modulation frequency

To set the modulation frequency press the **Freq** soft-key. The frequency parameter will appear in the Edit Box and the modulating waveform in the Graph Box will show that frequency is being edited.



# 13 - Modulation

## Phase modulation (PM)

### Modulation shape

To set the modulation shape press the **Shape** soft-key. The currently selected shape will appear in the Edit Box and the soft-keys will change to a list of shapes available.



Select the modulation shape required by pressing the appropriate key then press the **Done** soft-key to return to the top-level modulation menu.

All the parameters for phase modulation are now set.

# 13 - Modulation

## Amplitude shift keying (ASK)

### Amplitude shift keying (ASK)

To select amplitude shift keying, press the MOD key to access the modulation menu and then press the Type soft-key to show the display below.

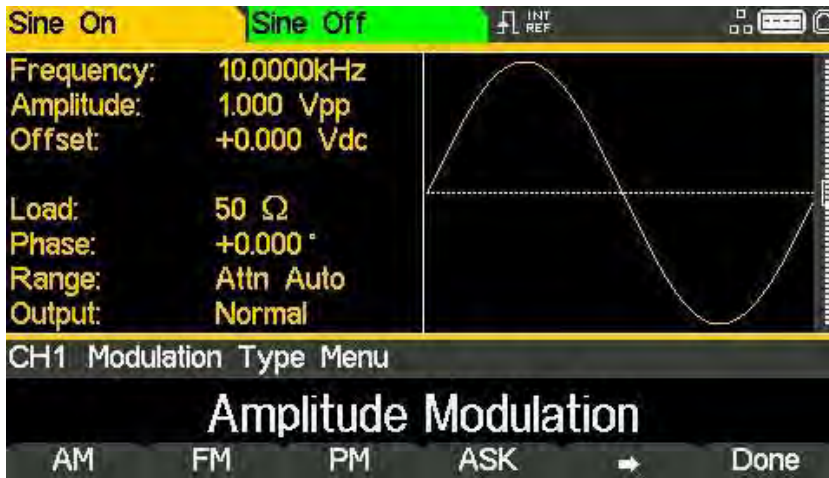

The soft-keys present all of the available modulation types.

If ASK is not already selected press the ASK soft-key followed by the Done key to return to the top-level modulation menu.

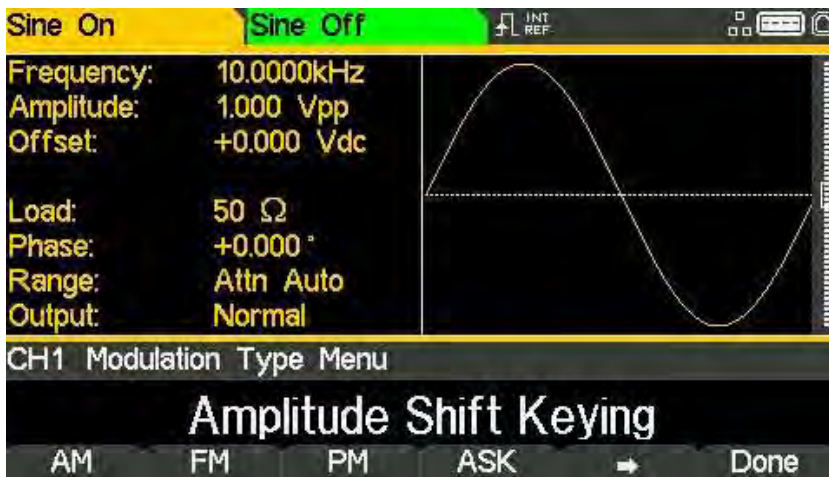

Press On/Off soft-key to apply the selected modulation.

# 13 - Modulation

## Amplitude shift keying (ASK)

### Modulation source

To select the modulation source, press the Source soft-key, the options are Internal or External.

Internal will use an internally generated trigger signal.

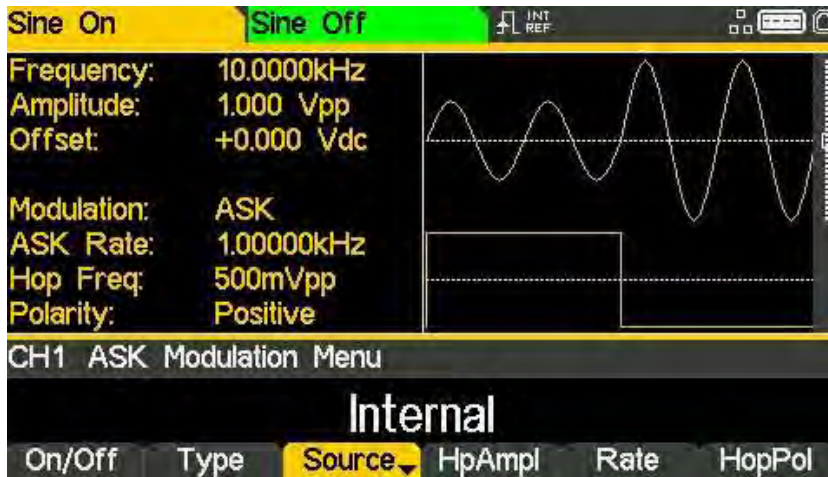

External will use the signal present at the TRIG / COUNT (DC) IN connector and the Rate parameter will no longer be editable. The Graph Box will show a switching carrier and a square-wave as the modulating waveform irrespective of the source of the switching signal.

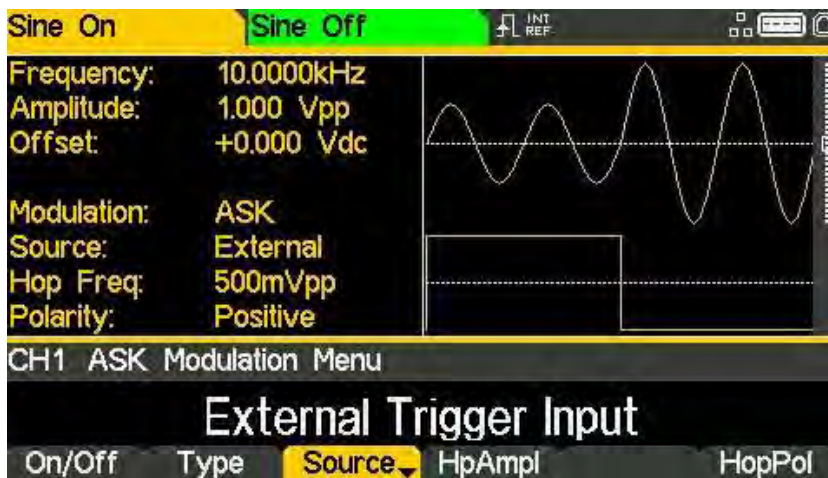



# 13 - Modulation

## Amplitude shift keying (ASK)

### Hop amplitude

Amplitude shift keying will generate the carrier amplitude while the switching signal is false and the hop amplitude while the switching signal is true. To set the hop amplitude press the **HpAmpl** soft-key. The hop amplitude parameter will appear in the Edit Box.



### Switching rate

To set the switching rate press the **Rate** soft-key. The rate parameter will appear in the Edit Box and the modulating waveform in the Graph Box will show that the switching rate is being edited.

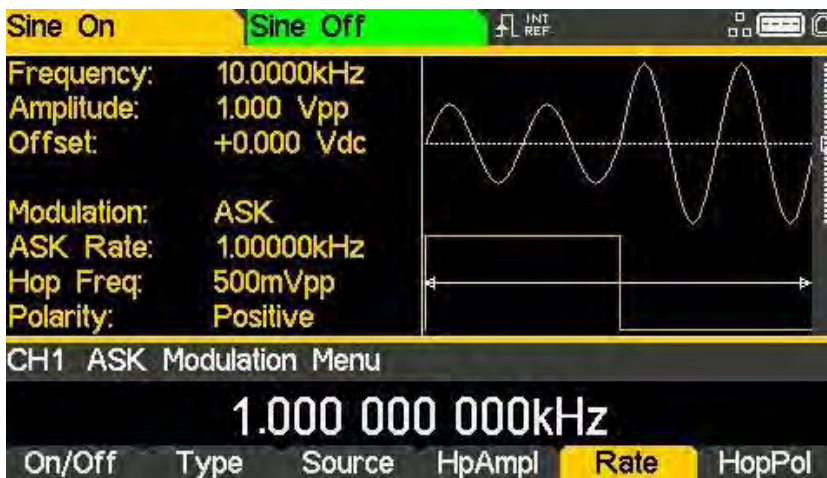

# 13 - Modulation

## Amplitude shift keying (ASK)

### Hop polarity

To set which level of the switching signal will output the hop amplitude press the **HopPol** soft-key. The currently selected polarity will appear in the Edit Box.

The options are **Positive** or **Negative**.

Setting **Positive** will cause ASK to generate the hop amplitude while the switching signal is high and the carrier amplitude while the switching signal is low.



Setting **Negative** will cause ASK to generate the hop amplitude while the switching signal is low and the carrier amplitude while the switching signal is high.



All the parameters for amplitude shift keying are now set.

# 13 - Modulation

## Frequency shift keying (FSK)

### Frequency shift keying (FSK)

To select frequency shift keying press the MOD key to access the modulation menu and then press the Type soft-key to show the display below.

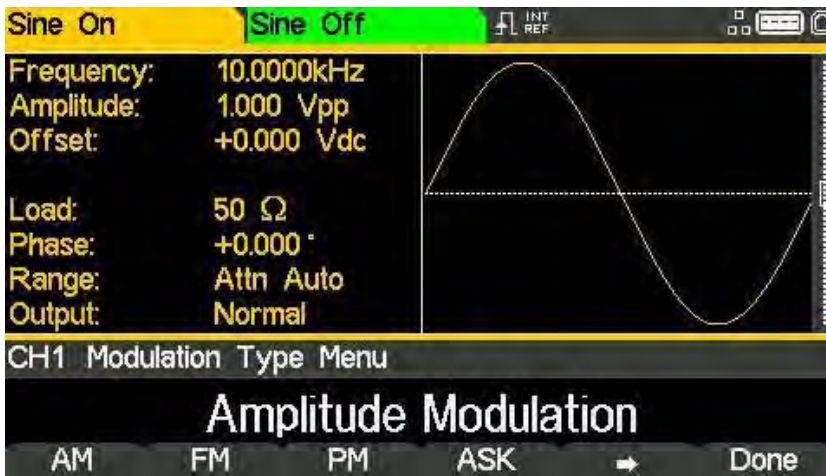

The soft-keys present all of the available modulation types.

If frequency shift keying is not already selected press the **FSK** soft-key followed by the **Done** key to return to the top-level modulation menu.

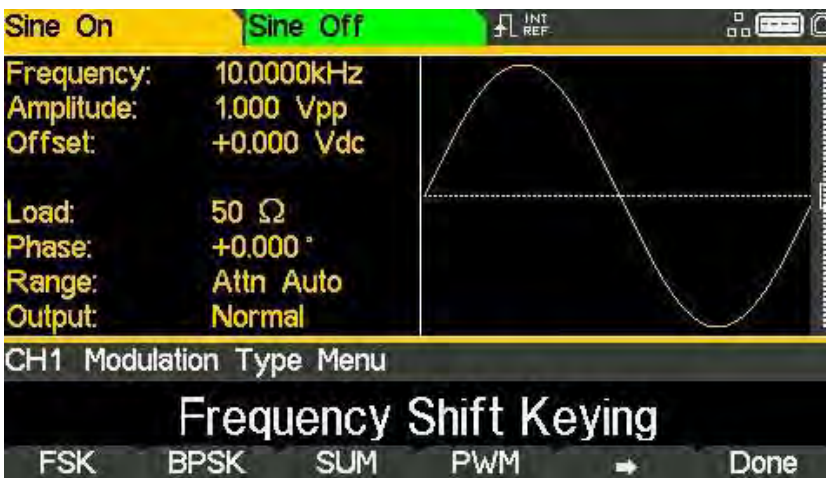

Press On/Off soft-key to apply the selected modulation.

# 13 - Modulation

## Frequency shift keying (FSK)

### Modulation source

To select the modulation source, press the Source soft-key, the options are Internal or External.

Internal will use an internally generated trigger signal.

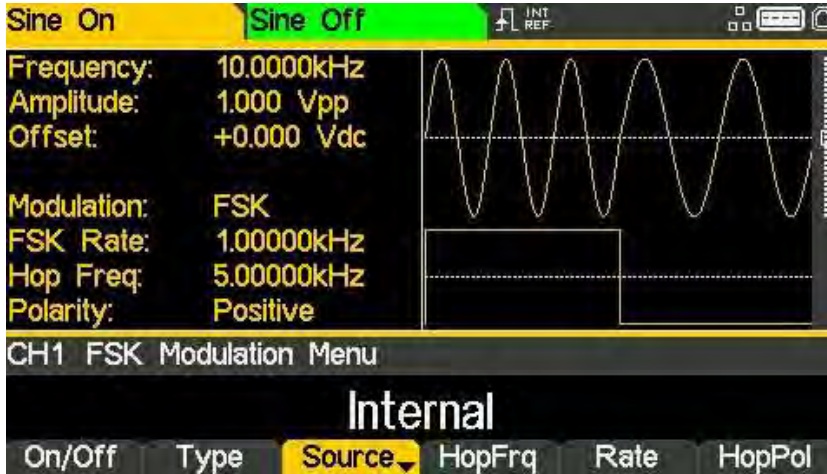

External will use the signal present at the TRIG / COUNT (DC) IN connector and the Rate parameter will no longer be editable. The Graph Box will show a switching carrier and a square-wave as the modulating waveform irrespective of the source of the switching signal.

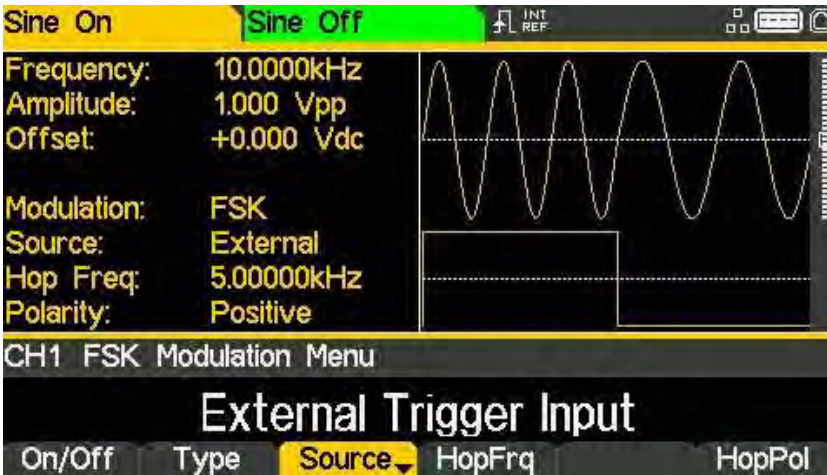

# 13 - Modulation

## Frequency shift keying (FSK)

### Hop frequency

Frequency shift keying will generate the carrier frequency while the switching signal is false and the hop frequency while the switching signal is true. To set the hop frequency press the **HopFrq** soft-key. The hop frequency parameter will appear in the Edit Box and the modulating waveform in the Graph Box will show that hop frequency is being edited.

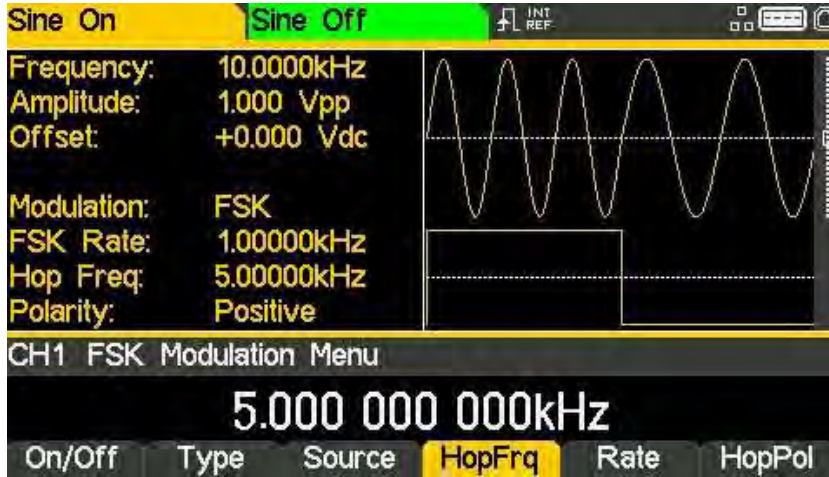

### Switching rate

To set the switching rate press the **Rate** soft-key. The rate parameter will appear in the Edit Box and the modulating waveform in the Graph Box will show that the switching rate is being edited.

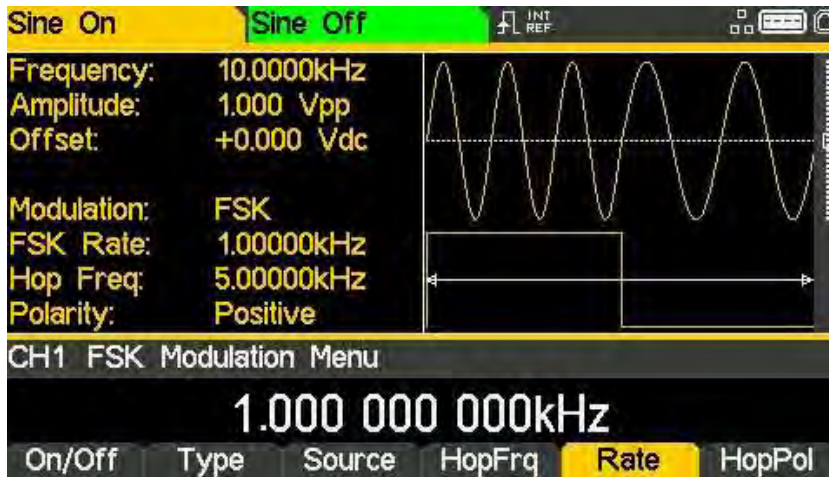

## 13 - Modulation

### Frequency shift keying (FSK)

#### Hop polarity

To set which level of the switching signal will output the hop frequency press the **HopPol** soft-key. The currently selected polarity will appear in the Edit Box.

The options are **Positive** or **Negative**.

Setting **Positive** will cause FSK to generate the hop frequency while the switching signal is high and the carrier frequency while the switching signal is low.

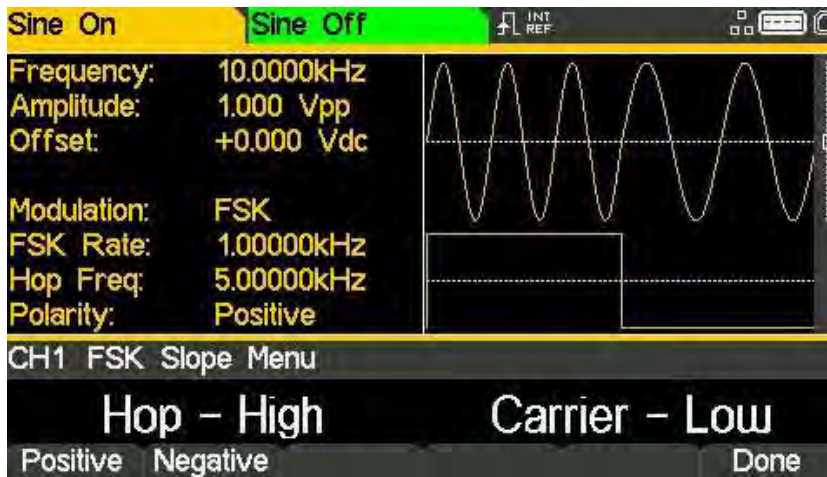

Setting **Negative** will cause FSK to generate the hop frequency while the switching signal is low and the carrier frequency while the switching signal is high.



All the parameters for frequency shift keying are now set.

## 13 - Modulation

Binary phase shift keying (BPSK)

### Binary phase shift keying (BPSK)

To select BPSK press the MOD key to access the modulation menu and then press the **Type** soft-key to show the display below.

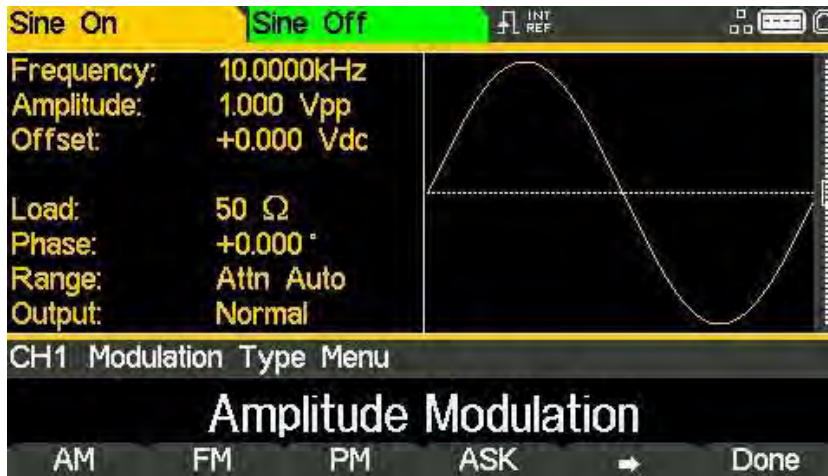

The soft-keys present all of the available modulation types.

If binary phase shift keying is not already selected press the **BPSK** soft-key followed by the **Done** key to return to the top-level modulation menu.

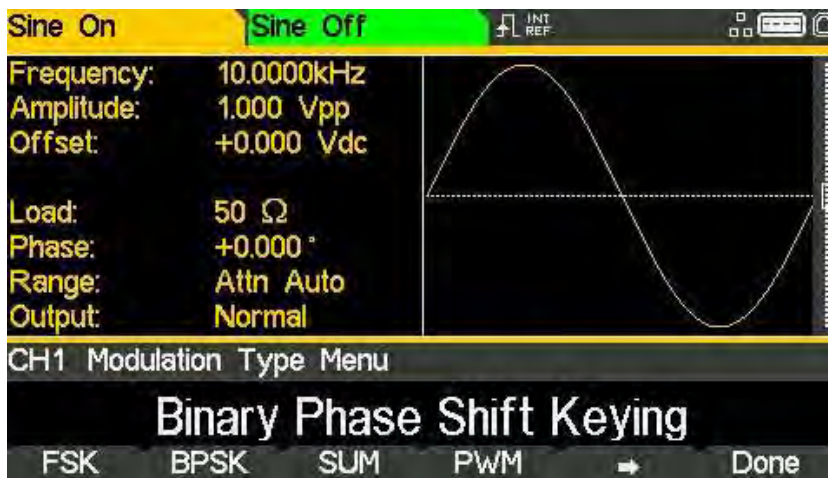

Press On/Off soft-key to apply the selected modulation.

# 13 - Modulation

Binary phase shift keying (BPSK)

## Modulation source

To select the modulation source, press the Source soft-key, the options are Internal or External.

Internal will use an internally generated trigger signal.

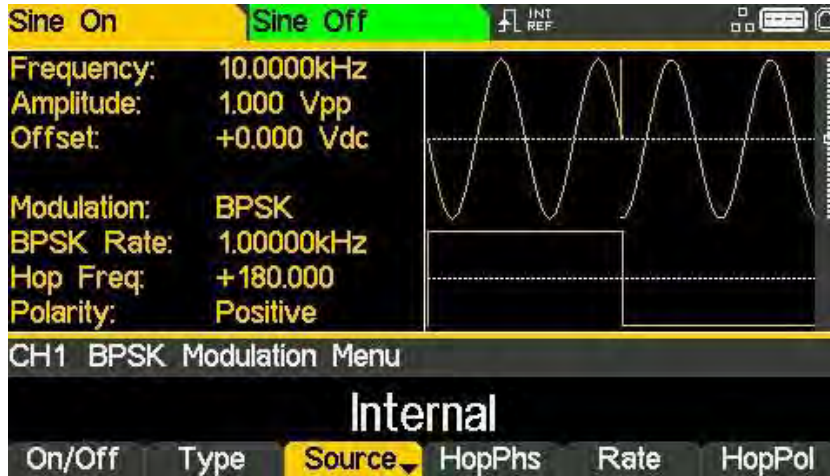

External will use the signal present at the TRIG / COUNT (DC) IN connector and the Rate parameter will no longer be editable. The Graph Box will show a switching carrier and a square-wave as the modulating waveform irrespective of the source of the switching signal.

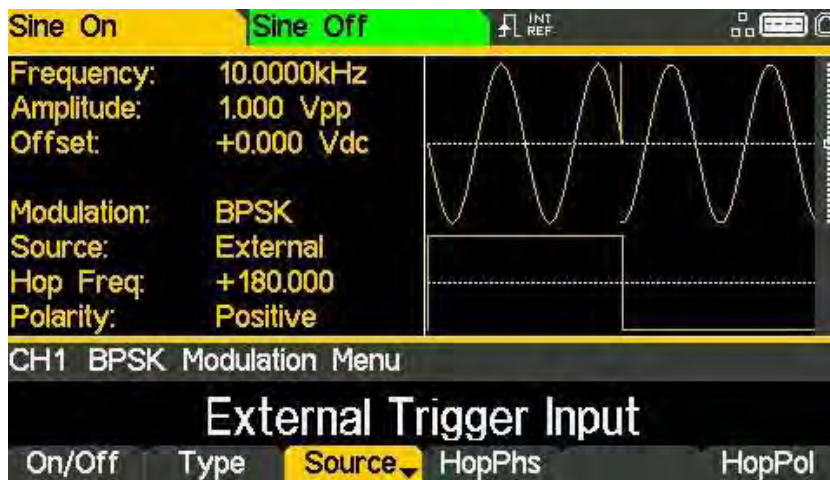



# 13 - Modulation

Binary phase shift keying (BPSK)

## Hop phase

Binary phase shift keying will generate the carrier phase while the switching signal is false and the hop phase while the switching signal is true. To set the hop phase press the **HopPhs** soft-key. The hop phase parameter will appear in the Edit Box.



## Switching rate

To set the switching rate press the **Rate** soft-key. The rate parameter will appear in the Edit Box and the modulating waveform in the Graph Box will show that the switching rate is being edited.

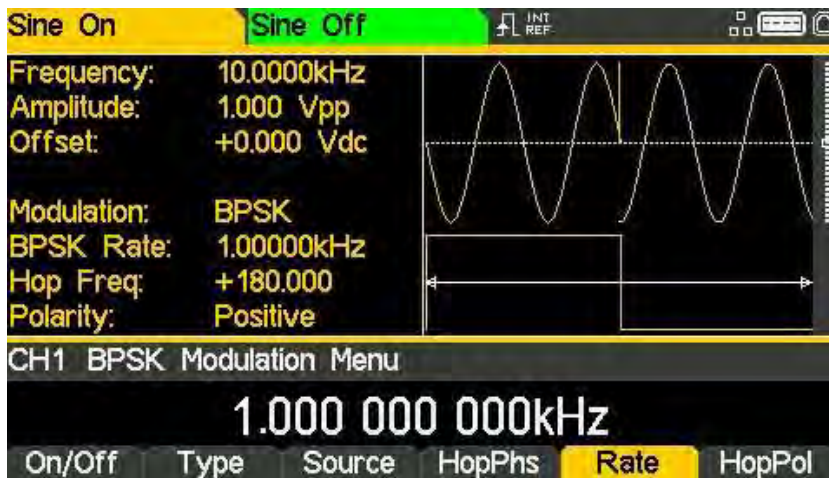

# 13 - Modulation

## Binary phase shift keying (BPSK)

### Hop polarity

To set which level of the switching signal will output the hop phase press the HopPol soft-key. The currently selected polarity will appear in the Edit Box.

The options are Positive or Negative.

Setting Positive will cause BPSK to generate the hop phase while the switching signal is high and the carrier phase while the switching signal is low.



Setting Negative will cause BPSK to generate the hop phase while the switching signal is low and the carrier phase while the switching signal is high.



All the parameters for binary phase shift keying are now set.

# 13 - Modulation

## SUM modulation

### SUM modulation

To select SUM modulation, press the MOD key to access the modulation menu and then press the Type soft-key to show the display below.



The soft-keys present all of the available modulation types.

If SUM modulation is not already selected press the SUM soft-key followed by the Done key to return to the top-level modulation menu.

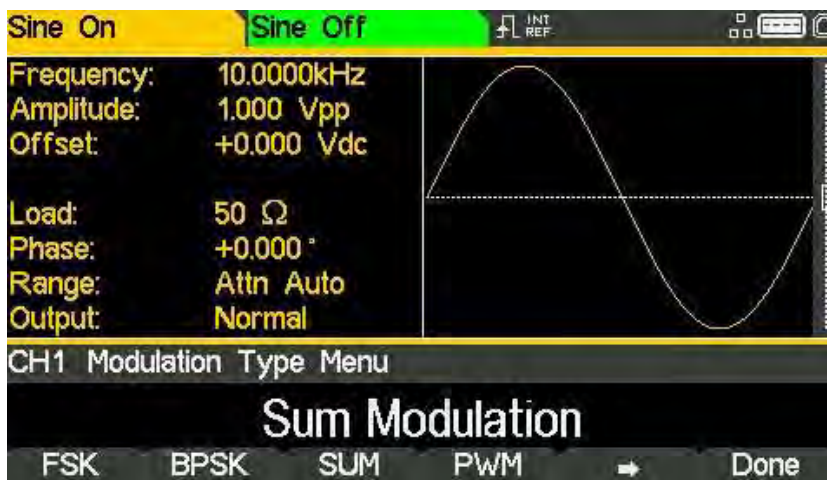

Press On/Off soft-key to apply the selected modulation.

# 13 - Modulation

## SUM modulation

### Modulation source

To select the modulation source, press the **Source** soft-key, the options are **Internal** or **External**.

**Internal** will use the waveform specified in the shape parameter and the Graph Box will show that shape as the modulating waveform.

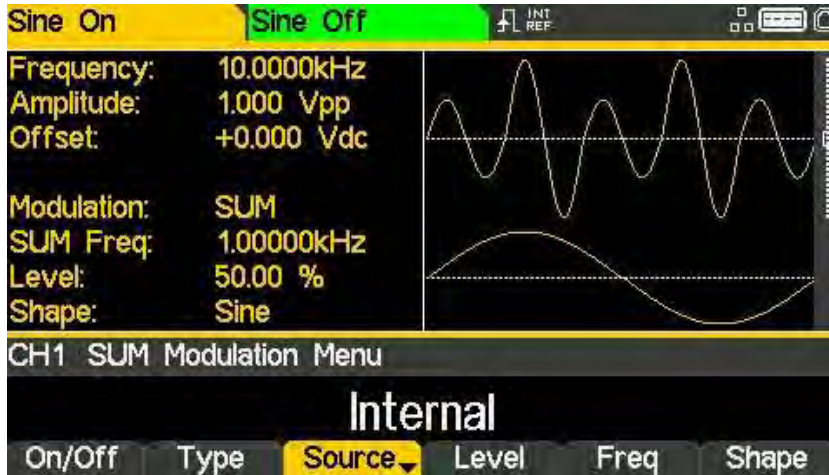

**External** will use the signal present at the MOD IN connector and the **Freq** and **Shape** parameters will no longer be editable. The Graph Box will always show a sinewave as the modulating waveform if the source is set to External.

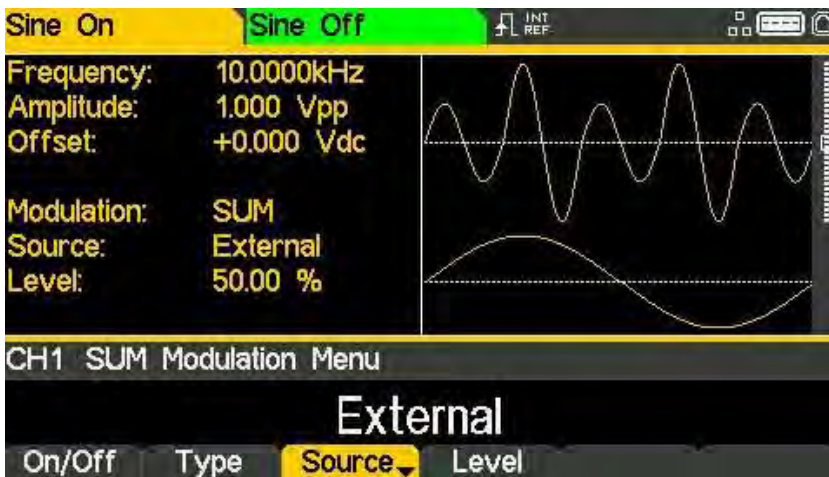

# 13 - Modulation

## SUM modulation

### Modulation level

To set the modulation Level press the **Level** soft-key. The parameter will appear in the Edit Box and the modulating waveform in the Graph Box will show that Modulation Level is being edited.



### Modulation frequency

To set the modulation frequency press the **Freq** soft-key. The frequency parameter will appear in the Edit Box and the modulating waveform in the Graph Box will show that frequency is being edited.

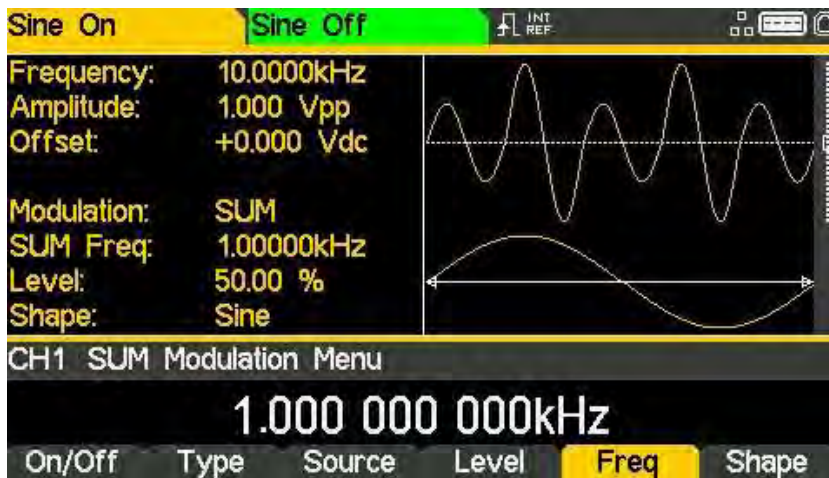

# 13 - Modulation

## SUM modulation

### Modulation shape

To set the modulation shape press the **Shape** soft-key. The currently selected shape will appear in the Edit Box and the soft-keys will change to a list of shapes available.

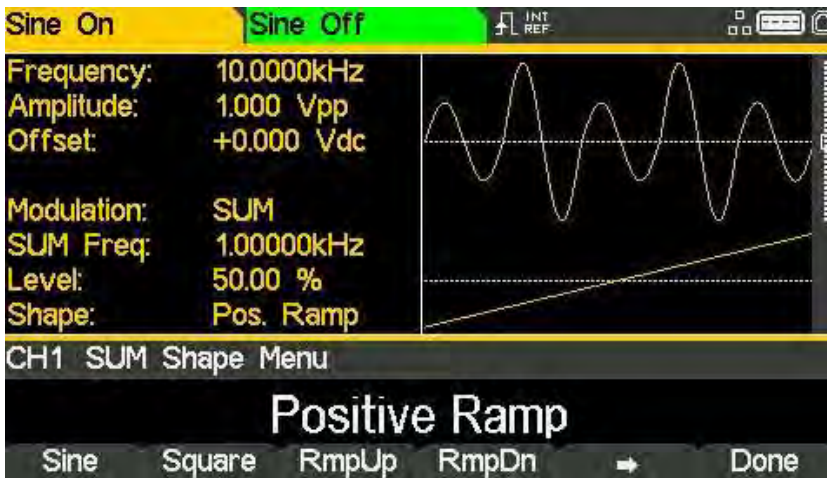

Select the modulation shape required by pressing the appropriate key then press the **Done** soft-key to return to the top-level modulation menu.

All the parameters for SUM modulation are now set.

# 13 - Modulation

## Pulse width modulation (PWM)

### Pulse width modulation (PWM)

Pulse width modulation is applicable to pulse only. Select Pulse then select PWM by pressing the MOD key to access the modulation menu and then press the Type soft-key to show the display below.



The soft-keys present all of the available modulation types.

### NOTE



PWM can only be applied to Pulse carrier waveform.

If PWM is not already selected press the **PWM** soft-key followed by the **Done** key to return to the top-level modulation menu.

Press **On/Off** soft-key to apply the selected modulation.

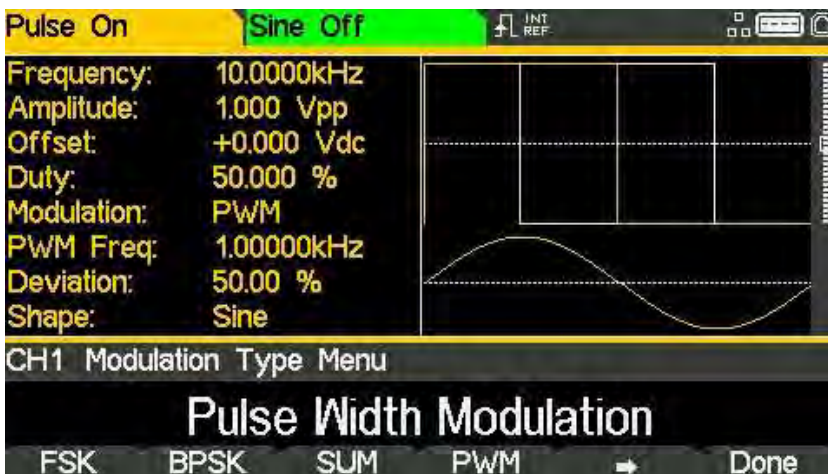

## 13 - Modulation

### Pulse width modulation (PWM)

#### Modulation source

To select the modulation source, press the **Source** soft-key, the options are **Internal** or **External**.

**Internal** will use the waveform specified in the shape parameter and the Graph Box will show that shape as the modulating waveform.



**External** will use the signal present at the MOD IN connector and the **Freq** and **Shape** parameters will no longer be editable. The Graph Box will always show a sinewave as the modulating waveform if the source is set to external.

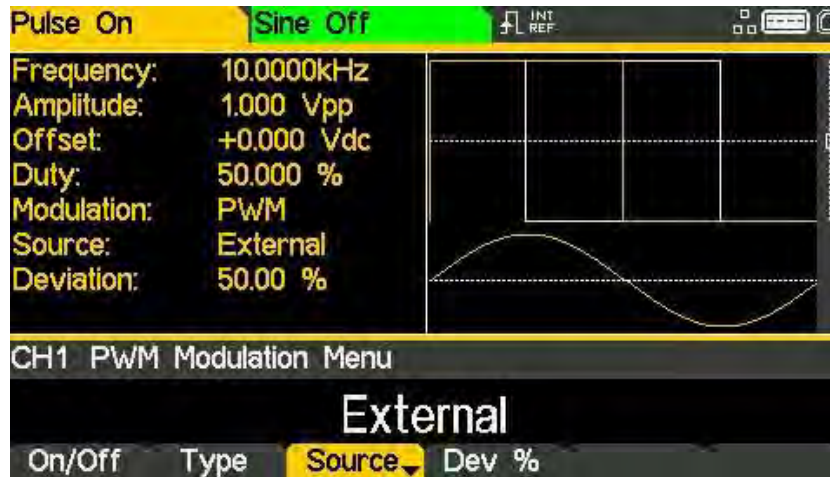



# 13 - Modulation

## Pulse width modulation (PWM)

### Pulse width deviation

To set the pulse width deviation press the Dev % soft-key. The deviation parameter will appear in the Edit Box and the modulating waveform in the Graph Box will show that deviation is being edited.



### Modulation frequency

To set the modulation frequency press the Freq soft-key. The frequency parameter will appear in the Edit Box and the modulating waveform in the Graph Box will show that frequency is being edited.



# 13 - Modulation

## Pulse width modulation (PWM)

### Modulation shape

To set the modulation shape press the **Shape** soft-key. The currently selected shape will appear in the Edit Box and the soft-keys will change to a list of shapes available.



Select the modulation shape required by pressing the appropriate key then press the **Done** soft-key to return to the top-level modulation menu.

All the parameters for pulse width modulation are now set.

## 14 - Sweep

Sweep application

# 14. SWEEP

The sweep function allows the carrier frequency to be swept using small frequency steps from the start frequency to the stop frequency. There are over 4000 steps and this remains constant for all sweep times and frequency spans.

### NOTE



All waveforms can be swept with the exception of Pulse, Noise and PRBS

### Sweep application

To select sweep, press the SWEEP key to access the sweep menu and then press the **On/Off** soft-key to apply the currently selected sweep parameters to the currently selected carrier waveform. The SWEEP key will become illuminated when sweep is activated.

The screen below shows the effect of enabling sweep when sine is the selected waveform.



The Parameters Box now shows the current sweep parameters of **Sweep time**, **Start**, **Stop** and **Time**, and **Sweeping** is shown in the **Frequency** field. The Graph Box shows the sweep waveform type below a representation of the swept carrier waveform. The Edit Box contains the selected parameter, in this case sweep time.

## 14 - Sweep

### Sweep application

To change the carrier waveform parameters, press the WAVES key, followed by the waveform required.



Notice that **Sweeping** still shows in the **Frequency** field of the Parameters Box and the **SWEEP** key still glows, indicating that sweep is still active.

It is still possible to edit amplitude and dc offset in the PARAMS menu



To return to the Sweep menu to edit the sweep parameters press the SWEEP key again. To turn off sweep press the **On/Off** soft-key in the sweep menu.

## 14 - Sweep

### Sweep type

#### Sweep type

To see the sweep settings in the parameters box, sweep must be activated. To activate sweep, press the **On/Off** soft key.

To set the sweep type press the **Type** soft-key. The currently selected type will appear in the Edit Box and soft-keys will change to a list of sweep types available.



The arrows indicate up or down sweeps. With any of the **Lin** types selected the sweep changes the frequency at a linear rate; with **log** types selected the sweep spends an equal time in each frequency decade. The up arrows indicate a sweep from start frequency to stop frequency. The down arrows indicate a sweep from stop frequency to start frequency.

Select the sweep type required by pressing the appropriate key then press the **Done** soft-key to return to the top-level sweep menu.

## 14 - Sweep

### Sweep type

#### Start and stop frequency

Press Freq soft-key to access sweep frequency parameters. To set the start or stop frequency press the Start or Stop soft-keys.



The frequency parameter will appear in the Edit Box and the sweep waveform type in the Graph Box will show that start or stop frequency is being edited.

#### NOTE



The start frequency must be lower than the stop frequency, if this is not the case an error will be generated

# 14 - Sweep

## Sweep type

### Centre and span

The instrument also allows the start and stop frequency parameters to be entered in terms of centre and span. Pressing either the **Start** or **Stop** soft-key while it is highlighted will switch the mode from start/stop to centre/span.

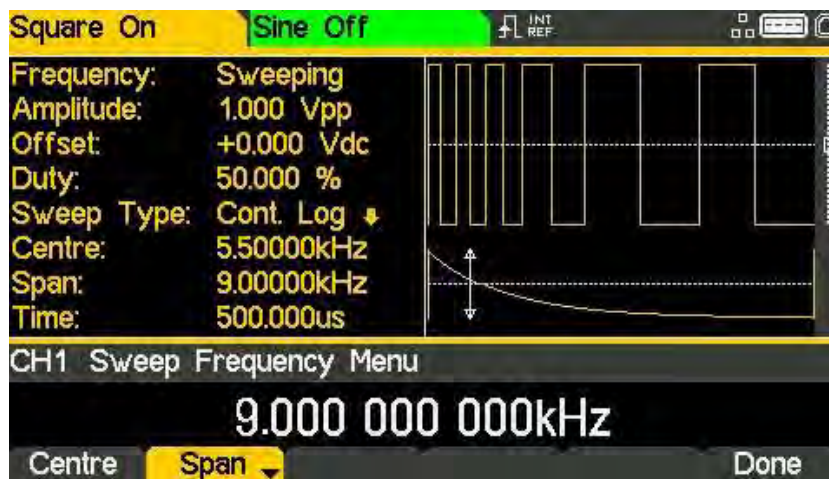

With centre/span mode selected the Edit Box shows the parameter, the Parameters Box shows Centre and Span in place of Start and Stop and the Graph Box changes to show the parameter which is being edited.

To return to start/stop mode press the highlighted Centre or Span soft-key.

Press the Done soft-key to return to the top-level sweep menu.

## 14 - Sweep

Sweep time

### Sweep time

To set the sweep time press the **Time** soft-key. The time parameter will appear in the Edit Box and the Graph Box will show that sweep time is being edited.



### Sweep mode

The sweep mode specifies how the sweep will be started. This may be continuous or triggered. The trigger signal for the sweep can be internal from the trigger generator, external from the TRIG / COUNT (DC) IN connector or manual by pressing the TRIGGER key.

To set the mode press the **Mode** soft-key. The mode parameter will appear in the Edit Box.

### Continuous sweep

The default mode is continuous sweep. In this mode the sweep will proceed to the end and immediately start again with no pause.





# 14 - Sweep

## Sweep mode

### Triggered sweep

Pressing the Mode soft-key again will change the mode to triggered sweep.

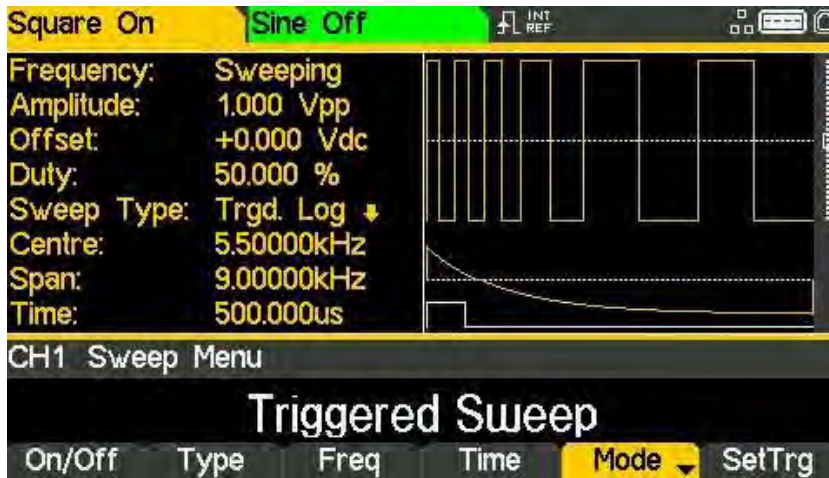

In this mode the sweep will proceed to the end and then waits for a trigger to start again. The soft-keys will change and a trigger waveform will be added to the Graph Box. The Sweep Type field in the Parameters Box will show that the sweep is now triggered.

When the mode is set to triggered mode, SetTrg soft-key appears in the sweep main menu to allow access to control and set the sweep trigger parameters. Press the SetTrg soft-key to set trigger parameters.



## 14 - Sweep

### Sweep mode

Press the Source key to set trigger source. The three possible trigger sources are:

- Internal Trigger - using the internal trigger generator
- External Trigger - using the signal at the TRIG / COUNT (DC) IN connector
- Manual Trigger - from the Trigger key.



Select the trigger source then press  soft-key.

Pressing the Period soft-key allows the period of the internal trigger generator to be set. The Edit Box shows the current period and the Graph Box changes to show that the trigger period is being edited.

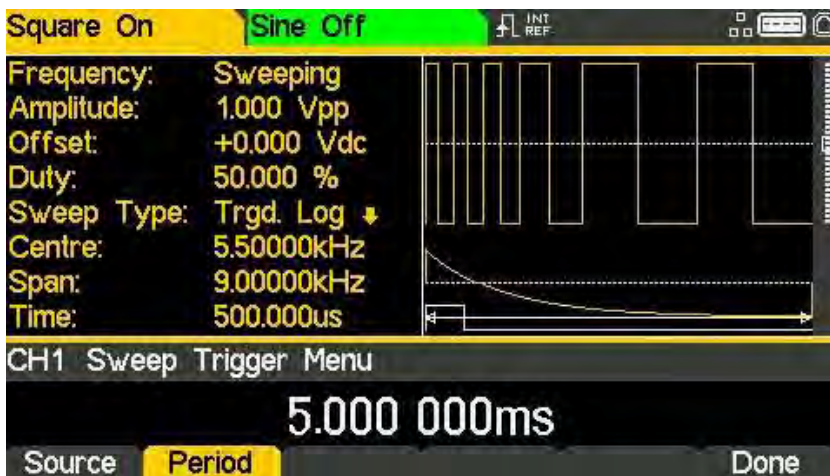

## 14 - Sweep

### Sweep mode

When the source is external trigger, the **Period** soft-key is replaced by **Slope** soft-key.

Repeated presses of the **Slope** soft-key key select between **Positive Slope** and **Negative Slope**.



The trigger waveform in the Graph Box changes to show the edge in use.



When the source is manual trigger, there are no additional parameters to be set. Press the **TRIGGER** key to send a manual trigger. Press the **Done** soft-key to return to the top-level sweep menu.

All the parameters for sweep are now set.

# 15. BURST

## Overview

The burst function allows the carrier waveform to be triggered, produce a user specified number of cycles and then stop and wait for the next trigger.

For a PRBS waveform burst the count is the PRBS bit-rate and not the PRBS cycles. This allows the generation of incomplete or multiple sequences. A new trigger always restarts the PRBS from the start.

Alternatively, the number of cycles may be Infinite. In this case the trigger starts the waveform. As above, PRBS waveforms will be triggered from the start.

For a noise waveform, the noise generation will be reset to its start condition when triggered. This allows it to generate the same random noise sequence again without the need to wait for the repetition time to elapse.

The Gated Burst function causes the carrier waveform to run while the trigger is true and stop while the trigger is false. The gated function is also available with Noise as the carrier waveform.

In all the above cases, except Noise and PRBS, the operation will always produce an exact number of cycles of the carrier waveform.

The trigger signal for the burst can be internal from the trigger generator, external from the TRIG / COUNT (DC) IN connector or manual by pressing the TRIGGER key.

# 15 - Burst

## Burst application

### Burst application

To select burst, press the BURST key to access the burst menu and then press the On/Off soft-key to apply the currently selected burst parameters to the currently selected carrier waveform. The BURST key will become illuminated.

The screen below shows the effect of enabling burst when sine is the selected waveform.

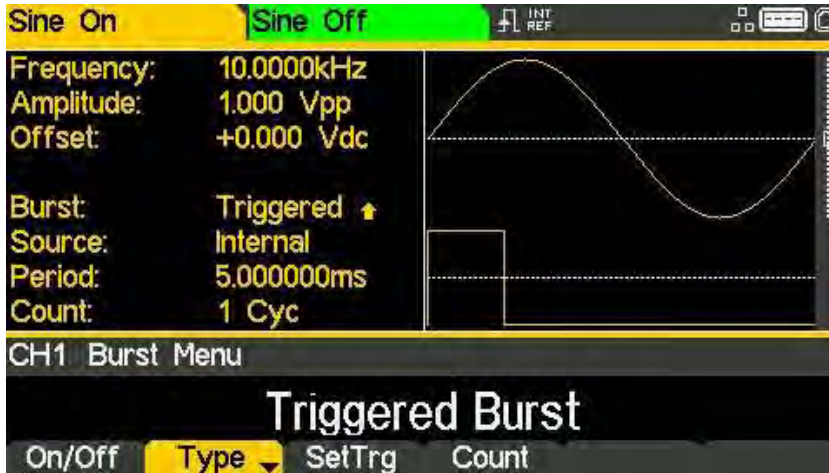

The Parameters Box now shows the current burst parameters of Burst, Source, Period, and Count, and Triggered is shown in the Burst field. The Graph Box shows the burst waveform trigger below a representation of the carrier waveform. The Edit Box contains the selected parameter, in this case Type.

To change the carrier waveform parameters, press the WAVES key, followed by the waveform required.



Notice that Triggered still shows in the Burst field of the Parameters Box and the BURST key still glows, indicating that burst is still active. To return to the Burst menu to edit the burst parameters press the BURST key again. To turn off burst press the On/Off soft-key in the burst menu.

# 15 - Burst

## Burst type

### Burst type

To set the burst type press the **Type** soft-key.

Pressing the **Type** soft-key while it is highlighted will change the type from **Triggered Burst** to **Gated Burst** and vice-versa.

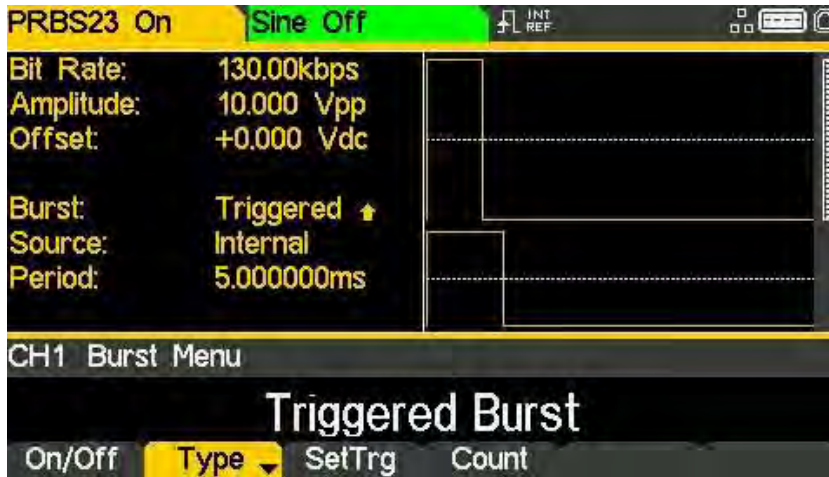

The currently selected type will appear in the Edit Box, the **Burst** field in the Parameters Box will show the type and the Graph Box will show the trigger waveform below a representation of the carrier waveform with the burst type applied.

## 15 - Burst

Burst count

### Burst count

To set the burst count press the **Count** soft-key. The burst count parameter will appear in the Edit Box.

#### NOTE



Only Triggered Burst has a Count soft-key.



The carrier waveform in the Graph Box will show a representation of the burst as the count is edited.

#### NOTE



When a value of more than 3 cycles is selected, the graph box will show **\*\*\*\*\*** to represent this.

Press the **Count** soft-key again to change the count from a finite number to infinite count.



When the number of cycles is infinite, the trigger starts the waveform. Press the **Restart** soft-key to stop the waveform and wait for a trigger to re-start the waveform.

# 15 - Burst

## Burst phase

Press the Count soft-key again to change the count back to finite count.

### Burst phase

To set the carrier start phase, press the WAVES key, followed by the waveform required, which will return the display to the carrier menu and then press the **Output** soft-key.

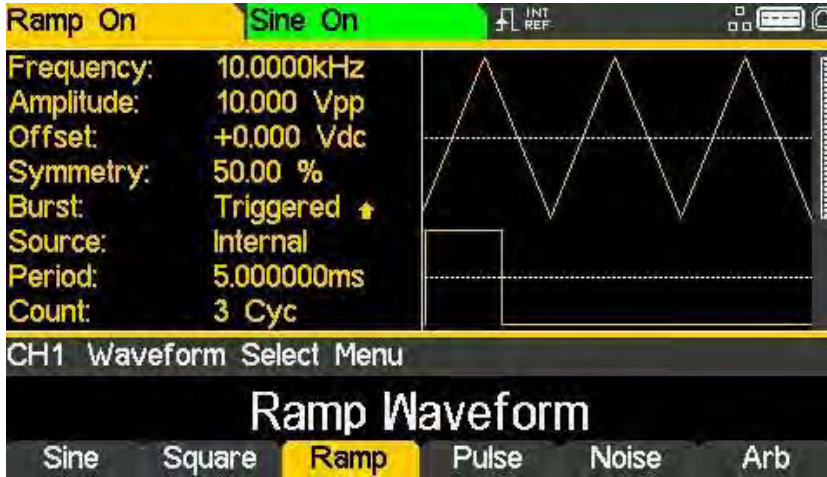

In the Output menu, press the Phase soft-key to change the start phase of the waveform. The phase parameter will appear in the Edit Box.



The carrier waveform in the Graph Box will show a representation of the carrier start phase as the phase is edited.

Press the highlighted BURST key to return the display to the burst menu.



## 15 - Burst

### Burst triggering

#### Burst triggering

Press the SetTrg soft-key in the burst menu to allow access to control and set the burst trigger parameters.

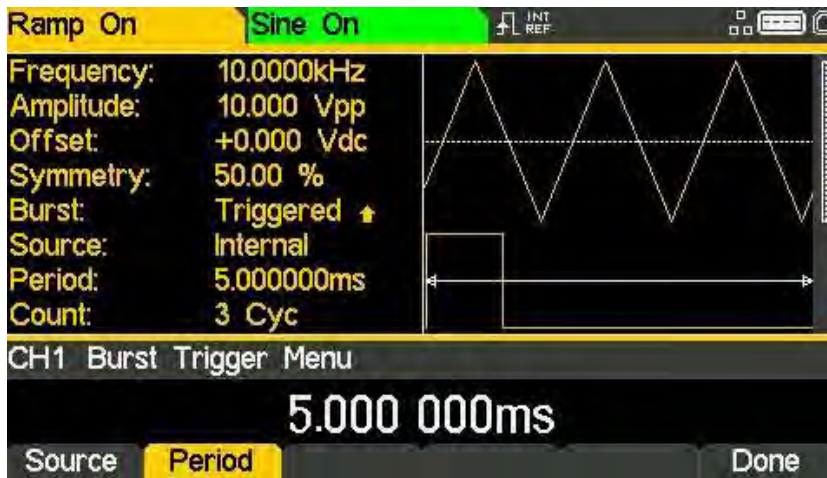

Press the Source key to set trigger source. The three possible trigger sources are:

- Internal Trigger - using the internal trigger generator
- External Trigger - using the signal at the TRIG / COUNT (DC) IN connector
- Manual Trigger - from the Trigger key

Select the trigger source then press  soft-key.



## 15 - Burst

### Burst triggering

#### NOTE



Period can only be set for Internal Trigger.

Pressing the **Period** soft-key allows the period of the internal trigger generator to be set. The Edit Box shows the current period and the Graph Box changes to show that the trigger period is being edited.



#### NOTE



Slope can only be set for External Trigger.

When the source is external trigger, the **Period** soft-key is replaced by **Slope** soft-key.



# 15 - Burst

## Burst triggering

Repeated presses of the Slope soft-key will select between Positive Slope and Negative Slope.



The trigger waveform in the Graph Box changes to show the edge in use.

When the source is manual trigger, there are no additional parameters to be set. Press the TRIGGER key to send a manual trigger. Press the Done soft-key to return to the top-level burst menu.



All the parameters for burst are now set.

# 16 - Dual Channel Operation

Channel selection

## 16. DUAL CHANNEL OPERATION

The instrument incorporates two separate generators in which all parameters can be set independently of each other.

### NOTE



The two generators use the same system clock and share a single Trigger Input and Modulation Input on the rear panel.

### Channel selection

Press the CH 1 or CH 2 key to select between channels for parameter editing.

The selected channel is indicated by a specified colour for easy identification.

Channel 1 is orange:



Channel 2 is green:

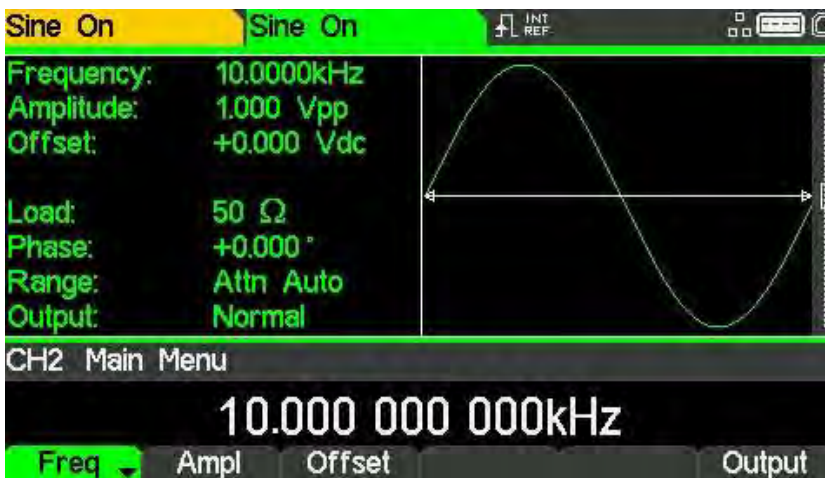

Any channel specific set parameters will always be shown in the specified colour for that channel.

System settings will be neutral in white, editing is also shown in white.

# 16 - Dual Channel Operation

Linked channels

## Linked channels

The two channels can be linked in a variety of ways. All of the options are available from the Dual Channel menu which is accessed by pressing the UTILITY key.



The utility menu presents several further menus which allow control of instrument and system capabilities not available directly from the menus described so far.

This section explains the options available by pressing the **Dual Ch** soft-key; the options accessed via the other soft-keys are described in the following sections.

Pressing the **Dual Ch** soft-key gives access to the dual channel capabilities of the instrument.

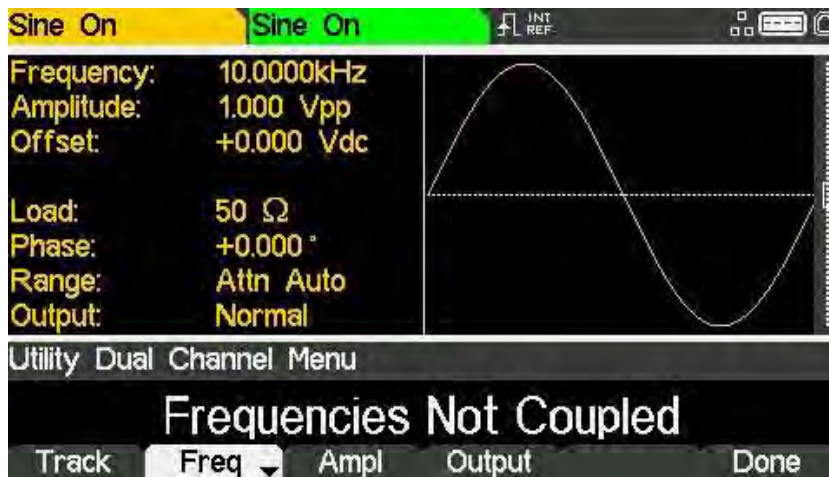

# 16 - Dual Channel Operation

Coupled operation

## Coupled operation

### NOTE



When a parameter is coupled it may be changed on either channel and the other channel will also change.

### NOTE



When coupled, the colour of the parameter that is being coupled becomes inverted in the parameters box on both channels.

To enable or disable frequency coupling press the **Freq** soft-key.

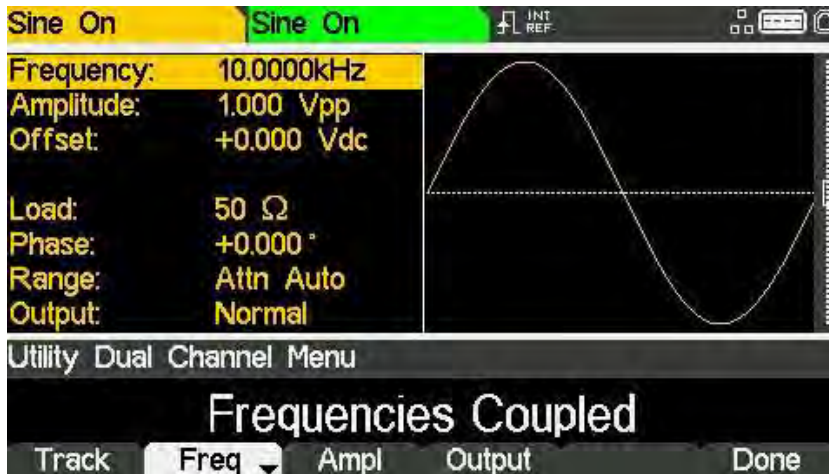

When entering frequency coupling modes, the instrument will automatically phase align the channels. The phases may become misaligned by subsequent parameter changes. To realign the phase at any time, press the **Align** soft-key from the carrier- output menu.



# 16 - Dual Channel Operation

## Coupled operation

To enable or disable amplitude and offset coupling press the **Ampl** soft-key.

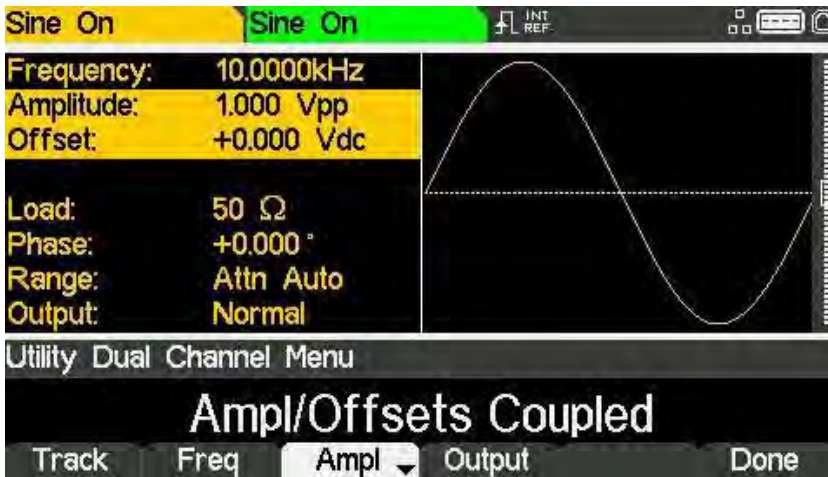

To enable or disable output coupling press the **Output** soft-key.

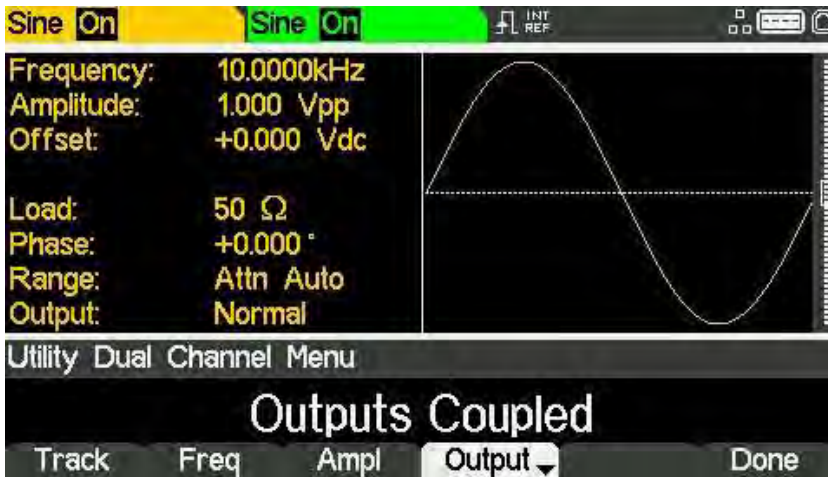

It is possible to set any combination of Frequency, Amplitude and Output coupling.

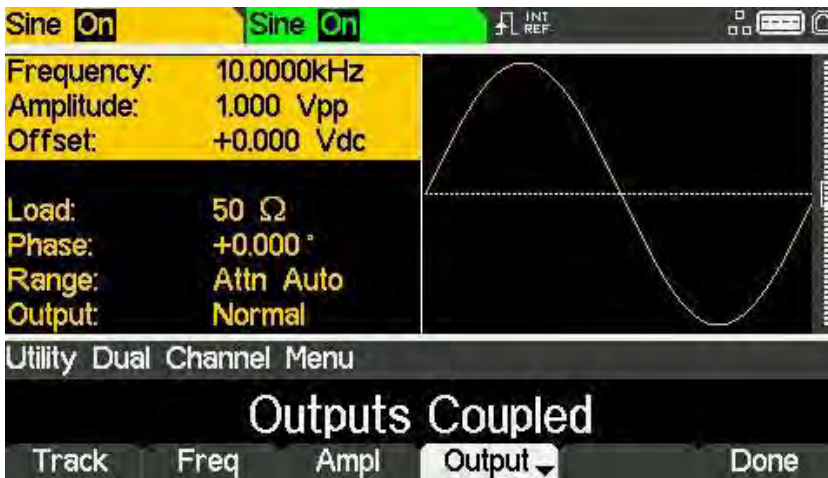

# 16 - Dual Channel Operation

Tracking options

## Tracking options

### NOTE



Tracking and coupled options are mutually exclusive; coupling must be disabled before enabling tracking.

Pressing the Track soft-key shows tracking menu.



With Tracking Off the two channels behave independently and changes to parameters on one channel do not affect the other channel.

Channel 2 can be set to exactly track Channel 1 by pressing the Equal soft-key.

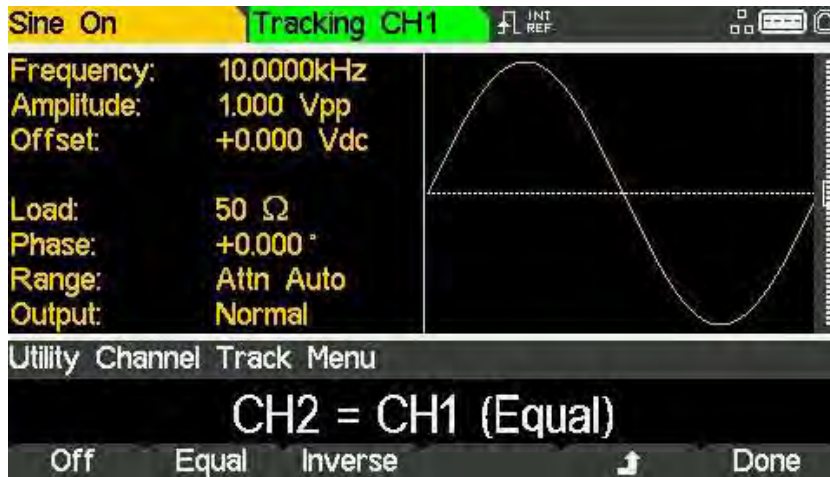



# 16 - Dual Channel Operation

## Tracking options

Tracking may be inverted by pressing the **Inverse** soft-key to produce a differential pair of signals.

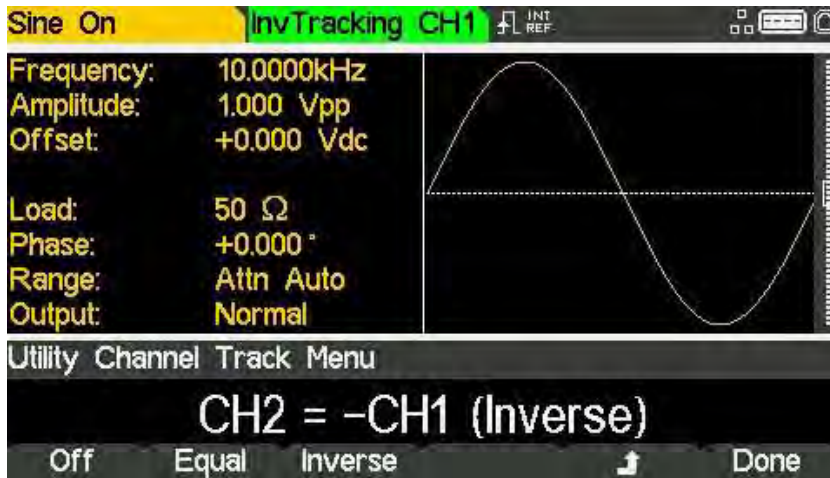

When either tracking option is enabled the waveforms will remain aligned at a phase of 0°.

To exit tracking mode, press the **Off** soft-key.

When Tracking is On, any parameter change is applied to both channels. It is not possible to switch between channels with the CH1 & CH2 keys, while tracking is selected **Tracking CH1** or **InvTracking CH1** is shown in place of the normal CH2 indicator

# 17 - External Counter

Counter menu

## 17. EXTERNAL COUNTER

The instrument offers the functionality of a counter. It can measure various parameters such as frequency, period, duty cycle, width and negative pulse width of an external input signal. The generator continues to perform normally when counter is enabled.

### Counter menu

To access counter related menus, press the UTILITY key.



Press Instr soft-key and then press FrCntr soft-key to access the counter capabilities of the instrument.

To enable or disable the counter, press the On/Off soft-key.



# 17 - External Counter

Counter source

## Counter source

The counter can either count the signal present at the TRIG / COUNT (DC) IN socket or the signal present at the REF / COUNT (AC) IN socket at the rear panel of the instrument. To select from the two counter sources, press the Source soft-key.

The TRIG / COUNT (DC) IN socket is DC coupled and has an input impedance of 10kΩ. The threshold is fixed at 1.2V to cater for 1.8V, 2.5V as well as 3.3V logic inputs. Select this input to count signals from 100mHz to >125MHz (typically 150MHz). The input sensitivity is 100mV.



The REF / COUNT (AC) IN socket is AC coupled. Select this input to count signals from 3Hz to >125MHz (typically 150MHz). The input sensitivity is 100mV.

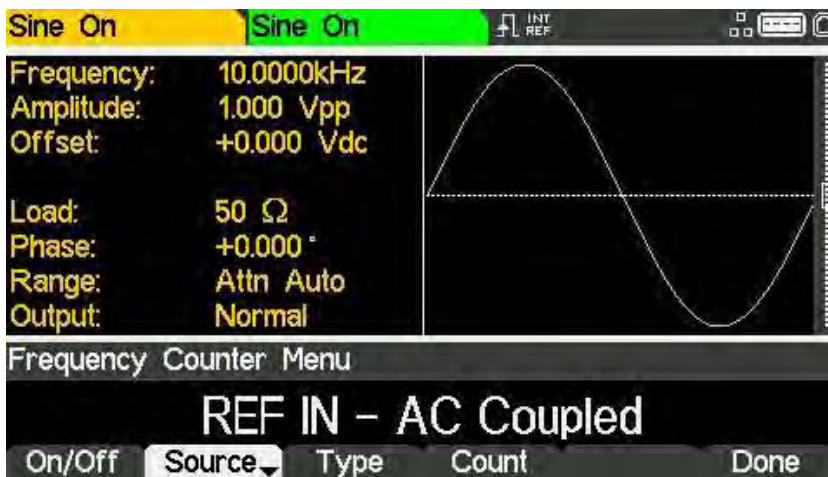

# 17 - External Counter

Counter type

## Counter type

Press the Type key to set counter type. The options are: frequency (freq), period, duty cycle (duty), width and negative width (NegWdt).

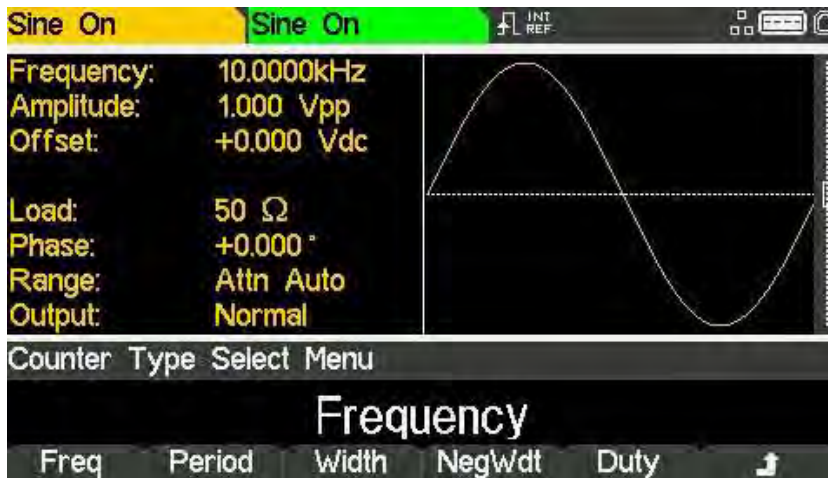

Select the counter type then press **↔** soft-key.

## Measurement

To display the measurement value, press the Count key. The Edit Box shows the current measurement. With no input signal at the selected input, the counter displays 'No signal' until an adequate input signal is applied.

When an adequate input signal is applied, the counter constantly measures and displays the reading in the Edit Box.

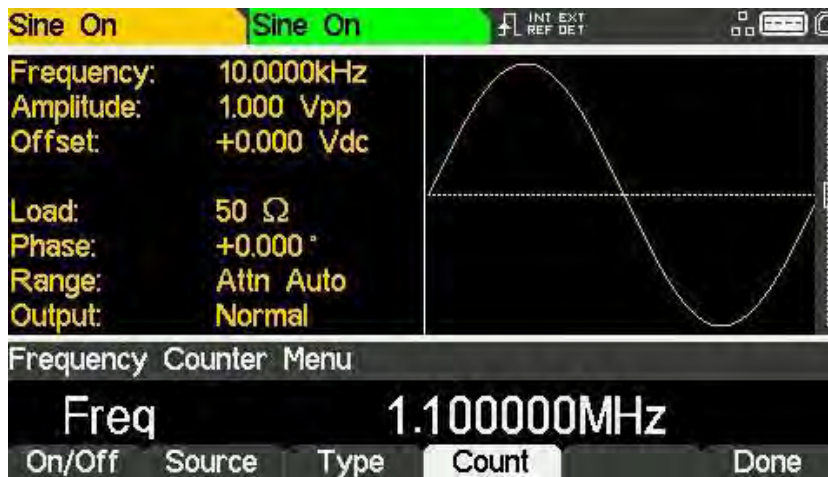

To exit the counter menu. Press the Done soft-key.

## 18 - Harmonic Waveforms

Selecting arb location to store harmonic waveforms

# 18. HARMONIC WAVEFORMS

(TGF4162 & TGF4242 only)

The instrument is capable of creating waveforms by the addition of sine wave harmonics, up to 16 harmonics can be used, chosen from up to the 50<sup>th</sup> order.

The amplitude and phase can be individually set for each harmonic.

Harmonic waveforms can also be created or edited in the Waveform Manager Plus V4.13 Windows application supplied on the Website: [www.aimtti.com](http://www.aimtti.com)

### NOTE



The created harmonic waveform is stored in one of the four user-defined arbitrary waveform locations. Any previous waveform stored in the same location is erased.

To output the harmonic waveform, select ARB as the carrier waveform and then select the user-defined arbitrary waveform where the harmonic is stored as the output either from the Arbs menu under Load.

### Selecting arb location to store harmonic waveforms

With arb as the selected waveform, pressing the Arbs soft-key switches to the Arb Arbs menu.



## 18 - Harmonic Waveforms

Selecting arb location to store harmonic waveforms

Pressing the **Hrmonic** soft-key opens the harmonic waveform sub-menu.



The name of the arb selected for storing the harmonic waveform is shown in the Edit Box. To select an arbitrary waveform location for storing the harmonic waveform press the appropriate soft-key.



# 18 - Harmonic Waveforms

Editing harmonic waveforms

## Editing harmonic waveforms

Press the Edit soft-key to show the harmonic waveform edit menu. The Edit Box shows all the parameters of the first harmonic content.



### Enable / disable

To enable or disable the current harmonic, press the On/Off soft-key.



# 18 - Harmonic Waveforms

## Editing harmonic waveforms

### Order

To set the order of the current harmonic, press the **Order** soft-key. Harmonic order can be set between 1 and 50.

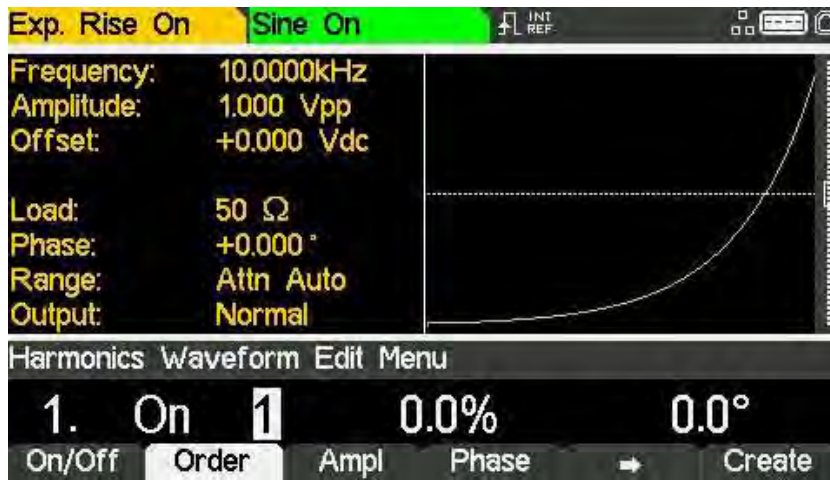

### Amplitude

To set the amplitude of the current harmonic, press the **Ampl** soft-key.



### NOTE



The amplitude is set as a percentage of the carrier waveform amplitude. Care should be taken when setting the amplitudes of the harmonic contents. The amplitude of the created harmonic waveform will be the phase sum of all components specified in the waveform. If the amplitudes are set such that the sum of all components exceed 100% at any point in the creation of the harmonic waveform, then the waveform at that point will be clipped.



# 18 - Harmonic Waveforms

## Editing harmonic waveforms

### Phase

To set the phase of the current harmonic, press the **Phase** soft-key.



To set the parameters of the next harmonic content press the **→** soft-key. Up to 16 harmonics can be defined, the parameters of which will show with successive presses of the **→** soft-key.

Once all harmonics are defined, press the **Create** soft-key to create the harmonic waveform and store it in the chosen user-defined arbitrary waveform location.



To output the harmonic waveform, select ARB as the carrier waveform and then select the user-defined arbitrary waveform where the harmonic is stored as the output from the **Arbs** menu under **Load**.



## 19. UTILITY MENU

Pressing the UTILITY key presents several further menus which allow control of instrument and system capabilities not available directly from the menus described so far.



Each of the soft-key selected menus is discussed in the following sections.

### System

Pressing the System soft-key gives control of some system level functions.

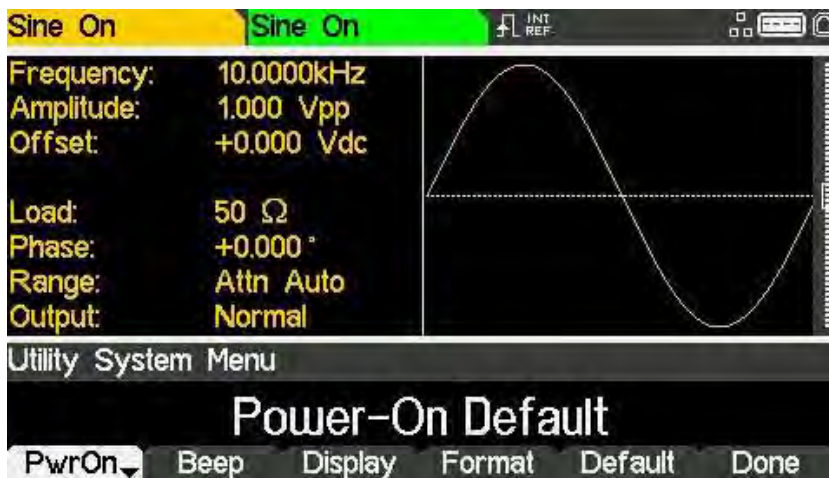

#### Power on state

Pressing the PwrOn soft-key will alternate between Power-On Default and Power-On Latest.

With Power-On Default selected the instrument will power up with the factory default parameters loaded.

With Power-On Latest selected the instrument will power up with the parameters as they were at the last power down.

# 19 - Utility Menu

System

## Beep state

Pressing the **Beep** soft-key will show the beep menu, the options are **Beep** and **Tick**, pressing either of the soft keys will alternate between **On** and **Off** for that particular type.

**Beep** refers to the sound associated with error and warning messages, when activated the screen will read **Message Beep On** and pop-up messages will be accompanied by a sound. These sounds are suppressed with **Message Beep Off**.



**Tick** refers to the sound made when the front panel keys are pressed, when activated the screen will read **Key Tick On** and each key press will make a short sound. These sounds are suppressed with **Key Tick Off**.



Press the  soft key to return to the Utility System Menu.

# 19 - Utility Menu

System

## Display control

Pressing the Display soft-key will show the Set Display Menu.

Pressing the Bright soft-key allows the display backlight brightness to be adjusted.

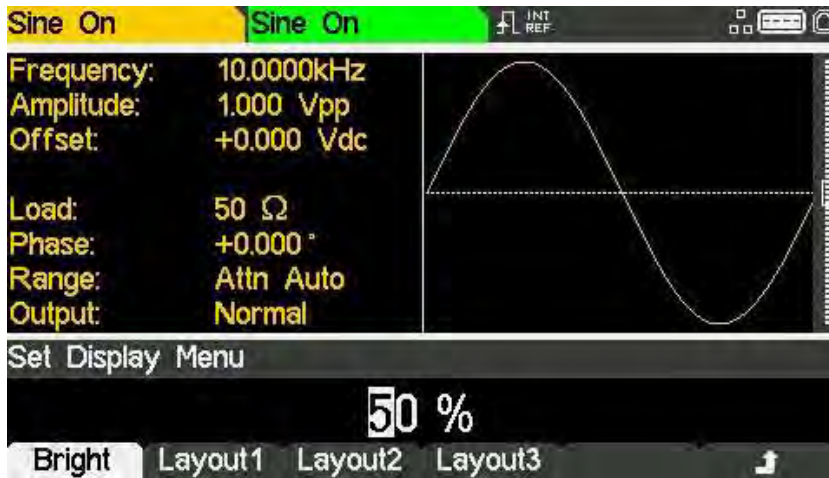

The three layout soft keys change the display as follows:

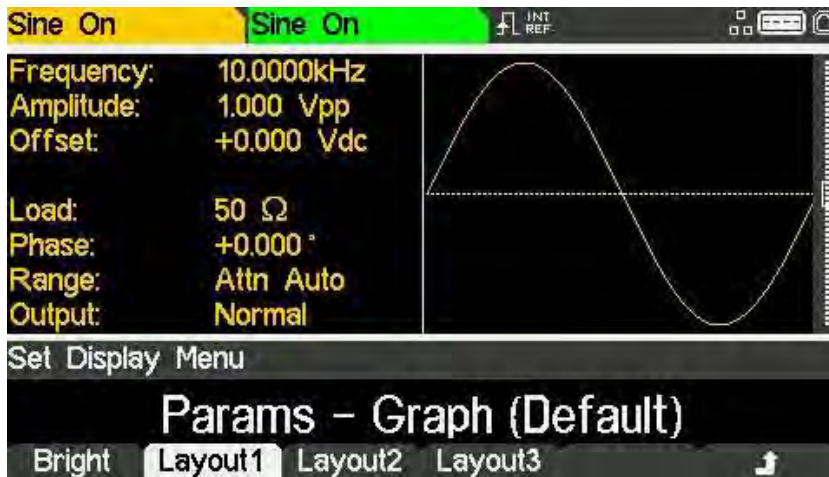

- Layout 1 (Default) Shows both the parameters and the graph for the selected channel.
- Layout 2 Shows the parameters for both channels simultaneously.
- Layout 3 Shows the graphs for both channels simultaneously.

For more information see 'Display options'

Press the  to return to the Utility System Menu.

# 19 - Utility Menu

System

## Number format

Pressing the Format soft-key will show the Format menu.

This menu allows the number format used in the Edit Box to be customised. The default is comma format which is selected by pressing the Comma soft-key.

In comma format, digits after the decimal point are arranged in groups of three with the groups separated by a comma.

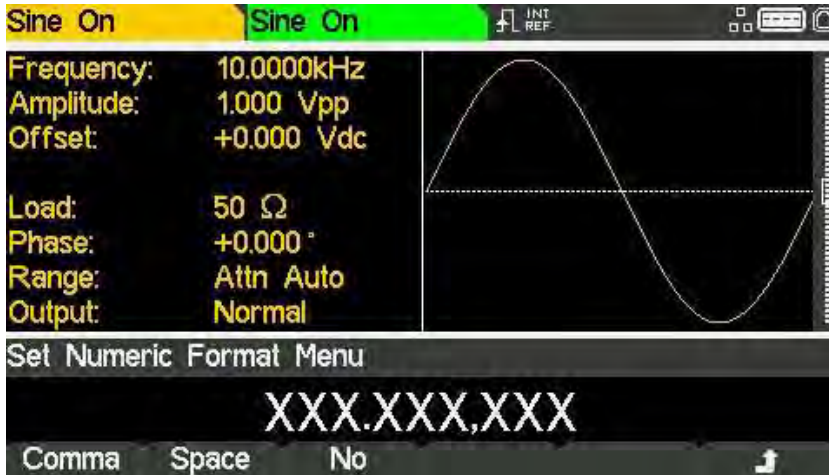

Pressing the Space soft-key will change to space format.

In 'space' format, digits after the decimal point are arranged in groups of three with the groups separated by a space.

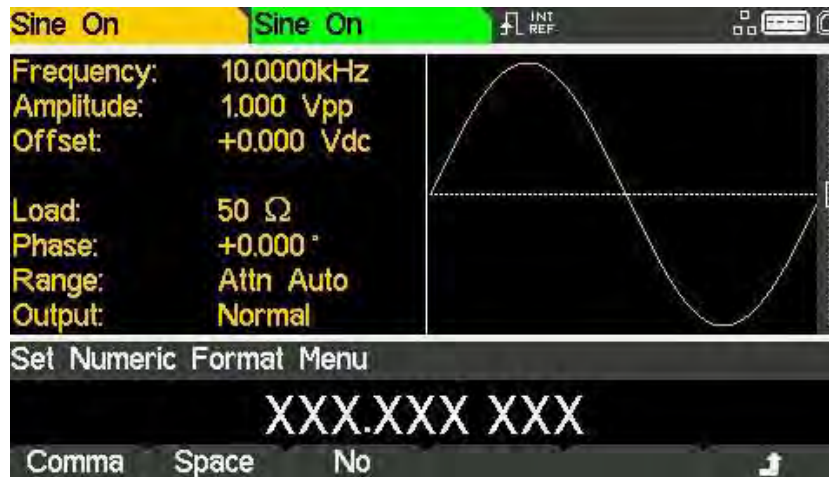

# 19 - Utility Menu

## System

Pressing the No soft-key will change to no format.

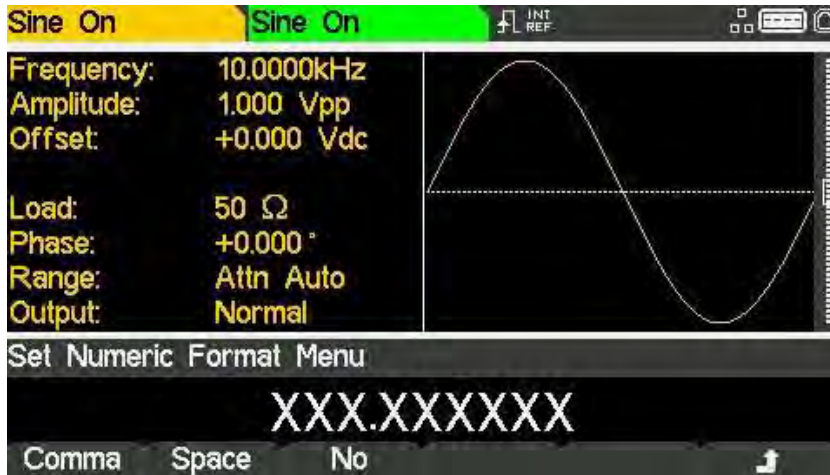

In 'no' format, digits after the decimal point are not grouped.

Press the  soft-key to return to the top-level system menu.

### Restore factory defaults

Pressing the Default soft-key allows all instrument parameters (except remote interface configuration parameters) to be restored to their factory settings as detailed in 'Appendix 1.



Press the Yes soft key to restore factory default settings or No soft key to return to the top-level system menu.

## 19 - Utility Menu

### Instrument settings

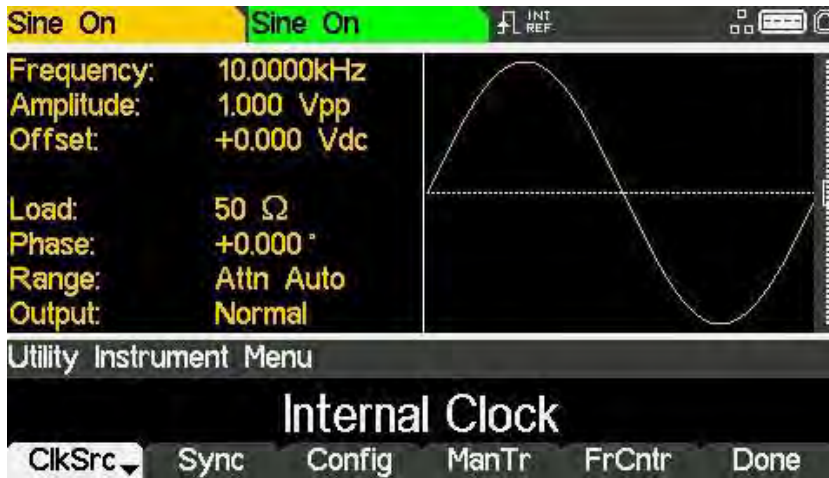

#### Instrument settings

Pressing the Instr soft-key opens the Utility Instrument sub-menu.



#### Reference clock source

Alternate presses of the ClkSrc soft-key change between using the Internal Clock and the External Clock. An external clock must have a frequency of 10MHz (+/-50kHz) and is applied to the rear panel socket 10MHz REF IN.

- If the internal clock is being used,  is displayed alongside INT REF.
- If an external clock is being applied or is being used,  appears alongside EXT REF.
- If a valid clock signal is detected (but not used),  INT REF is displayed alongside EXT DET.
- If the clock source is set to external and a valid external clock signal is not detected, the internal clock will be used by default and displayed followed by EXT ERR.

## 19 - Utility Menu

### Instrument settings

#### Sync type control

Pressing the Sync soft-key will show the sync type control menu.



The currently selected type will appear in the Edit Box and the soft-keys will change to a list of Sync types available.

The available Sync types are explained below:

- **Normal** - Automatically sets the most relevant Sync output for the instrument set-up.
- **Carrier** - A square wave at the same frequency and duty as the carrier waveform. Available for all waveforms except noise.
- **Trigger** - A buffered version of the Trigger signal.
- **Off** - Sync is turned off.

#### NOTE



Sync type is only relevant when channel 2 is configured to output channel 1 sync.

Press the  soft-key to return to the top-level instrument menu.



## 19 - Utility Menu

I/O

---

### Channel 2 configuration

Alternate presses of the **Config** soft-key changes the configuration of channel 2 between a separate independent output and channel 1 sync.

### Manual trigger select

The **TRIGGER** key can be set to send a manual trigger signal to just the current channel (single) or to both channels simultaneously (dual).

Pressing the **ManTr** soft-key alternates between **Manual Trigger Setup: Single** and **Manual Trigger Setup: Dual**.

### External counter

Press **FrCntr** soft-key to access the counter capabilities of the instrument. See 'External Counter' section for more information.

Once instrument parameters are set, press the **Done** soft-key to return to the utility menu.

## I/O

Pressing the **I/O** soft-key shows the remote interface menu. This allows activation and control of the installed interfaces.

See 'Remote operation' for full details of the use of the interfaces.

## Calibration

Pressing the **Calib** soft-key shows the opening screen for instrument calibration.

Full details on calibration may be found in 'Calibration'.

## Dual channel operation

Pressing the **Dual Ch** soft-key gives access to the dual channel capabilities of the instrument.

See Dual Channel Operation in 'Specification' for full details of these capabilities.

## Help

This gives access to the Help menu which is explained in the 'Help Operations'

## 20 - Stores Menu

Flash drive files and folders

---

# 20. STORES MENU

The stores menu gives access to both the instrument's local storage of arbitrary waveforms and parameter set-ups and to the external storage of a connected USB flash drive.

There are facilities for saving and recalling set-ups to and from local stores, deleting set-ups and arbitrary waveforms and copying waveforms and set-up files to and from a USB flash drive.

It is possible to save a waveform from a PC to a USB flash drive and then copy the waveform into the instrument for use.

### Flash drive files and folders

The instrument uses the folder called \TGF4XX2 for all file storage. This folder contains up to three more folders used as follows:

- \TGF4XX2\WAVES. This folder is used to store arbitrary waveforms. It is the only place where the instrument will look for waveform files. A waveform file has a file extension of .WFM. Files with any other extension will be ignored.
- \TGF4XX2\SETUPS. This folder is used to store set-ups. It is the only place where the instrument will look for set-up files. A set-up file has a file extension of .SU. Files with any other extension will be ignored.
- \TGF4XX2\FIRMWARE. This folder, if present, is used to store instrument firmware updates. This is the only place where the instrument will look for firmware update files. There are several types of file that may be in this folder. They should not be tampered with as they are checked by the firmware during use and, if corrupt, could render the instrument non-functional. After a successful update it is safe to delete the files in this folder. This option is offered by the boot-loader code in the instrument.

The instrument is able to read and write flash drives formatted FAT16 or FAT32. The instrument does not generate or use long filenames. A filename can only be up to eight characters in length.

When a new flash drive is attached to the instrument the required folders will be created automatically.

## 20 - Stores Menu

Using the stores menu

### Using the stores menu

Pressing the STORES key will show the stores menu.



Pressing the **Setup** soft-key displays the setup sub-menu.

The complete settings of the instrument can be saved to internal memory. Up to nine instrument set-ups can be stored internally as files under default or user-defined names. Set-up files can be copied to and from a USB Flash drive.



There are now two screen boxes between the Status Line and the Soft-key Labels:

The **Local:** Box on the left contains a list of appropriate local files.

The **Disk:** Box on the right contains a list of the appropriate files on an attached USB flash drive.

If no flash drive is attached the list will read **Please insert the disk**. It is not necessary to attach a flash drive for local only operations.

The top line of each box indicates which file type that the list contains and one box has ➔ (the selection arrow) pointing at the top line. The lists both show ➔ pointing at their selected file. One box is selected and one file from each list is selected. Moving the three selection arrows around defines the file or files that will be operated on by soft-key presses and the direction that data will flow between the files.

The files are listed by name and the number indicates the size of the file in bytes for a set-up file or the number of points in a waveform file.

## 20 - Stores Menu

Using the stores menu

There are nine local set-up stores and four local arbitrary waveform stores. The respective lists always show all of the stores even if they are empty. An empty store shows **Empty** instead of a size.

### Selections

The Source soft-key selects between local and disk. When local is selected, the selection arrow is in the **Local:** Box. When disk is selected, the selection arrow is in the **Disk:** Box.



### NOTE



When no files are stored on the attached flash drive, the disk box will read 'Setups not found'

The file selection arrows are moved by first selecting the required box, as above. A file is then selected by turning the KNOB until the selection arrow is next to the required filename. If there are more files than will fit on the screen the list will scroll when the arrow reaches the top or bottom of the box.

## 20 - Stores Menu

Operations on set-up files

### Operations on set-up files

There are nine local set-up stores numbered 1 to 9. The number is shown next to the filename in the **Local:** Box. Initially the files will all be empty. The file names are **SETUP1** to **SETUP9** by default but they may be changed as they are used.

There are four operations available for set-up files as shown by the soft-key labels **Copy**, **Save**, **Recall** and **Delete**.

#### NOTE



The copy operation will not be available if no flash drive is attached.

#### Copy

The copy operation allows set-up files to be copied between local storage and an attached USB flash drive.

To copy a file from local to disk:

1. Select the **Local:** Box by pressing the **Source** soft-key.
2. Select the file to be copied using the **KNOB**.
3. Press the **Copy** soft-key.
4. Optionally modify the name of the file to receive the copy. This will default to the name of the file selected in step 2 above if it is not modified.

The screen below shows an example after performing the above actions. Here the file in store 3 will be saved to a set-up file on disk. The name will be **SETUP3** unless it is changed.



**Copy from:** shows that the source is **Local**.

**Copy to:** shows that the destination is **Disk**.

**Local** shows the file that will be written to **Disk**.

**Disk** and the **Edit Box** show the name of the file that will be written, the file name can be edited using the **KNOB** and cursor keys.

## 20 - Stores Menu

Operations on set-up files

### NOTE



A name with a length of up to 8 characters can be used.

The cursor keys < > are used to select the character and the KNOB is used to change the character. When the knob is turned clockwise the characters change in the following order:

0 to 9, @, A to Z, (space) ! # \$ % & ' ( ) -

Characters can be deleted or spaces created using the **Space** soft-key.

The **↵** key cancels the copy operation and returns to the set-up sub-menu.

The **Execute** soft-key starts the copy operation and returns to the set-up sub-menu when complete.



## 20 - Stores Menu

### Operations on set-up files

To copy a file from disk to local:

1. Select the **Local:** Box by pressing the **Source** soft-key.
2. Select the local store to receive the file from disk using the **KNOB**.
3. Select the **Disk** Box by pressing the **Source** soft-key.
4. Select the file to be copied using the **KNOB**.
5. Press the **Copy** soft-key.
6. Optionally modify the name of the local store to receive the copy. This will default to the name of the file selected in step 4 above if it is not modified.

The screen below shows an example after performing the above actions. Here the set-up in store 4 will be overwritten by the disk file **SETUPAS1**.



Copy from: shows that the source is **Disk**.

Copy to: shows that the destination is **Local**.

Disk shows the file that will be written to **Local**.

Local and the Edit Box show the name of the file that will be written, the file name can be edited using the **KNOB** and cursor keys.

The **Execute** soft-key starts the copy operation and returns to the set-up sub-menu when complete.



## 20 - Stores Menu

Operations on set-up files

### Save

The save operation allows the current instrument set-up to be saved to a local set-up store.

### NOTE



Save will function with or without an attached USB flash drive.

To perform a save operation first select the set-up store for the current instrument state to be saved to using the KNOB. Pressing the **Save** soft-key will show a screen similar to that below.



The name offered will be the same as the name in the selected set-up store when the **Save** soft-key was pressed. The Edit Box shows the name of the file that will be saved and the soft-key labels. The KNOB and cursor keys allow the name to be edited.

A name of up to 8 characters can be used.

The cursor keys < > are used to select the character and the KNOB is used to change the character. When the KNOB is turned clockwise the characters change in the following order:  
0 to 9, @, A to Z, (space) ! # \$ % & ' ( ) -

### NOTE



Characters can be deleted or spaces created using the **Space** soft-key.

The **↵** key cancels the save operation and returns to the set-up sub-menu.

The **Execute** soft-key starts the save operation and returns to the set-up sub-menu when complete.



## 20 - Stores Menu

### Operations on set-up files

---

#### Recall

The recall operation allows the current instrument set-up to be replaced with the set-up from a local store.

#### NOTE



Recall will function with or without an attached USB flash drive.

---

To perform a recall operation first select the set-up store containing the instrument state to recall using the KNOB.

Pressing the **Recall** soft-key will then recall the data and load it as the current instrument set-up.

#### Delete

The delete operation allows the set-up in the selected store to be deleted.

The store will then be marked empty and return to the original 'Setup' number.

Press the **Done** soft-key to return to the top-level stores menu.

## 20 - Stores Menu

Operations on waveform files

### Operations on waveform files

Pressing the **Arbs** soft-key displays the waveform sub-menu.



There are four local arbitrary waveform stores numbered 1 to 4. The number is shown next to the file name in the **Local:** Box. Initially the files are all set to the default four-point square-wave. The file names are set as **ARB1** to **ARB4** by default but they may be changed as they are used.

Each arbitrary waveform store can hold a waveform with a maximum of 8192 points.

There are two operations available for waveform files as shown by the soft-key labels **Copy** and **Delete**.

### NOTE



The copy operation will not be available if no USB flash drive is attached.

### Copy

The copy operation allows waveform files to be copied between local storage and an attached USB flash drive.

To copy a file from local to disk:

1. Select the **Local:** Box by pressing the **Source** soft-key.
2. Select the file to be copied using the **KNOB**.
3. Press the **Copy** soft-key.
4. Optionally modify the name of the file to receive the copy. This will default to the name of the file selected in step 2 above if it is not modified.

## 20 - Stores Menu

### Operations on waveform files

The screen below shows an example after performing the above actions. Here the file in store 3 will be saved to a waveform file on disk. The name will be ARB3 unless it is changed.



Copy from: shows that the source is Local.

Copy to: shows that the destination is Disk.

Local shows the file that will be written to Disk.

Disk and the Edit Box show the name of the file that will be written, the file name can be edited using the KNOB and cursor keys.

### NOTE



A name with a length of up to 8 characters can be used.

The cursor keys < > are used to select the character and the KNOB is used to change the character. When the KNOB is turned clockwise the characters change in the following order:

0 to 9, @, A to Z, (space) ! # \$ % & ' ( ) -

Characters can be deleted or spaces created using the Space soft-key.

The ↵ key cancels the copy operation and returns to the arbs sub-menu.

The Execute soft-key starts the copy operation and returns to the arbs sub-menu when complete.



## 20 - Stores Menu

### Operations on waveform files

---

To copy a file from disk to local:

1. Select the **Local:** Box by pressing the **Source** soft-key.
2. Select the local store to receive the file from disk using the KNOB.
3. Select the **Disk:** Box by pressing the **Source** soft-key.
4. Select the file to be copied using the KNOB.
5. Press the **Copy** soft-key.
6. Optionally modify the name of the file to receive the copy. This will default to the name of the file selected in step 4 above if it is not modified

The screen below shows an example after performing the above actions. Here the waveform in store 4 will be overwritten by the disk file ARBWAVE.



**Copy from:** shows that the source is **Disk**.

**Copy to:** shows that the destination is **Local**.

**Disk** shows the file that will be written to **Local**.

**Local** and the **Edit Box** show the name of the file that will be written, the file name can be edited using the KNOB and cursor keys.

### NOTE



A name with a length of up to 8 characters can be used.

---

## 20 - Stores Menu

### Operations on waveform files

The cursor keys < > are used to select the character and the KNOB is used to change the character. When the KNOB is turned clockwise the characters change in the following order:

0 to 9, @, A to Z, (space) ! # \$ % & ' ( ) -

Characters can be deleted or spaces created using the **Space** soft-key.

The **↩** key cancels the copy operation and returns to the set-up sub-menu.

The **Execute** soft-key starts the copy operation and returns to the set-up sub-menu when complete.



### Delete

The delete operation allows the waveform in the selected store to be deleted.

The store will contain the default four-point square-wave after waveform deletion.

Press the **Done** soft-key to return to the top-level stores menu.

## 21 - Help Operations

Help menu

# 21. HELP OPERATIONS

The instrument has a comprehensive help system which allows easy access to any Help page.

It is possible to get help in two ways:

- Help menu. Press the UTILITY and then press **Help** soft-key to access a list of help topics which give general information about instrument operations.
- Context sensitive help. Press and hold down any key, including soft-keys, for two seconds to access the Help page for that key.

There are two types of help screen.

- The Help menu. This is the screen that gives a list of general help topics.
- The Help topic screen. This is the screen that displays actual help texts.

## Help menu

Pressing Utility key and then **Help** soft-key will display the Help menu.

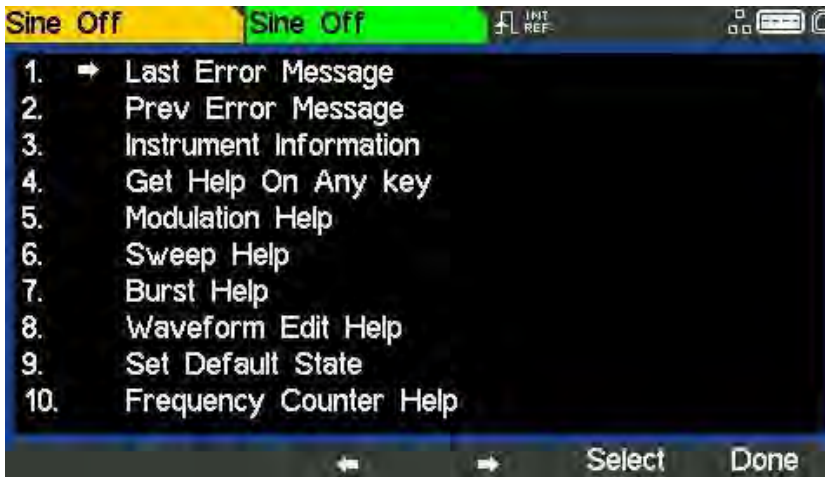

The Help menu uses all the screen space between the Status Line and the Soft-key Labels and contains a list of help topics. To show a topic use the ◀ and ▶ soft-keys to move the highlight back or forward through the list to select the required topic, then press the **Select** soft-key to show the topic screen.

Press the **Done** soft-key to exit from the Help menu.

## 21 - Help Operations

### Help topics

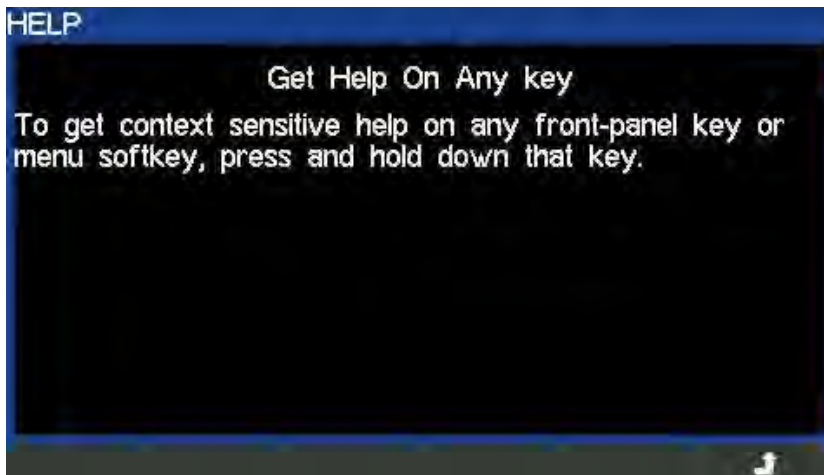

### Help topics

Selecting a Help topic from the Help menu or initiating context sensitive help will show a Help topic screen similar to that shown below.

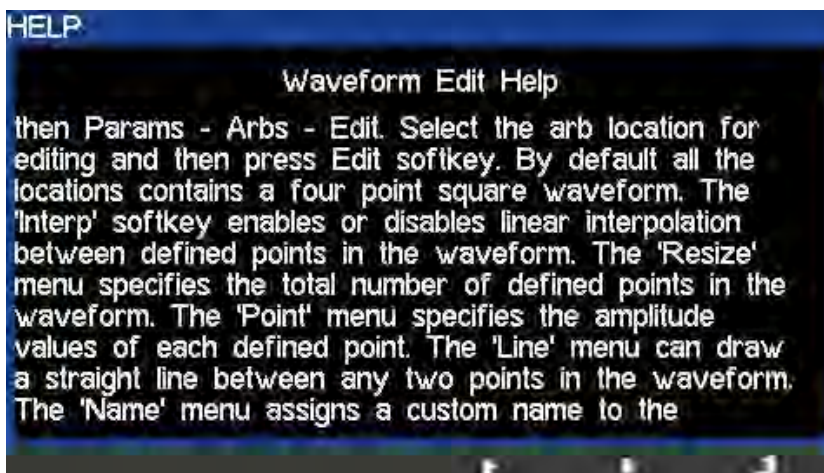
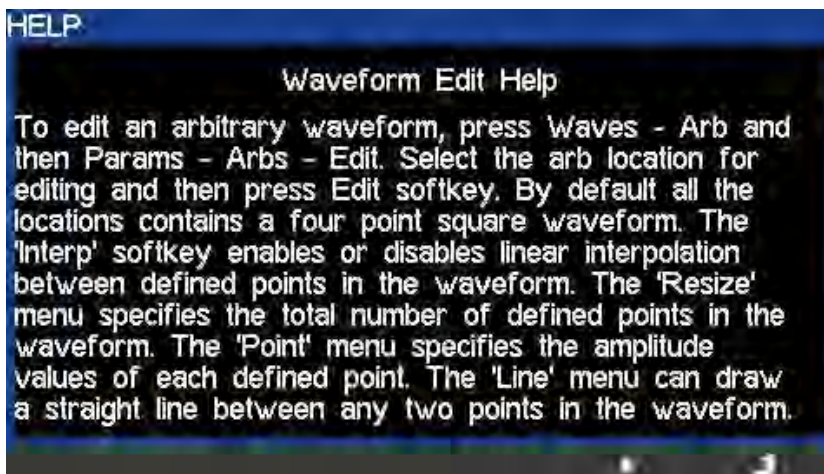

Below the topic heading is the topic text. If there is more text than will fit on the screen press the  soft-key to scroll the text up one line.



Continue scrolling until there is no more text indicated by the  soft-key label disappearing. Once the text has been scrolled the  soft-key may be used to scroll the text up one line. Pressing the  soft key will return to the previous screen.

## 22 - Editing Arbitrary Waveforms

Selecting an arbitrary waveform for editing

# 22. EDITING ARBITRARY WAVEFORMS

The instrument contains some basic editing capabilities for arbitrary waveforms. The Waveform Manager Plus V4.13 Windows application may be used when more comprehensive capabilities for creation and editing are required, this can be downloaded from the website:

[www.aimtti.com](http://www.aimtti.com)

Waveforms created in Waveform Manager Plus may be downloaded to the instrument via a remote-control interface or they may be transferred using a USB flash drive.

### Selecting an arbitrary waveform for editing

To use the instrument to edit an existing arbitrary waveform press the WAVES key followed by the Arb soft-key, then press the Arbs soft-key followed by the Edit soft-key.

The existing arbitrary waveforms appear on the first four soft-keys; the name is shown in the Edit Box and the selected arb is shown in the Graph Box if it is the currently selected arbitrary waveform.



Pressing the Edit Soft-key shows the edit menu.

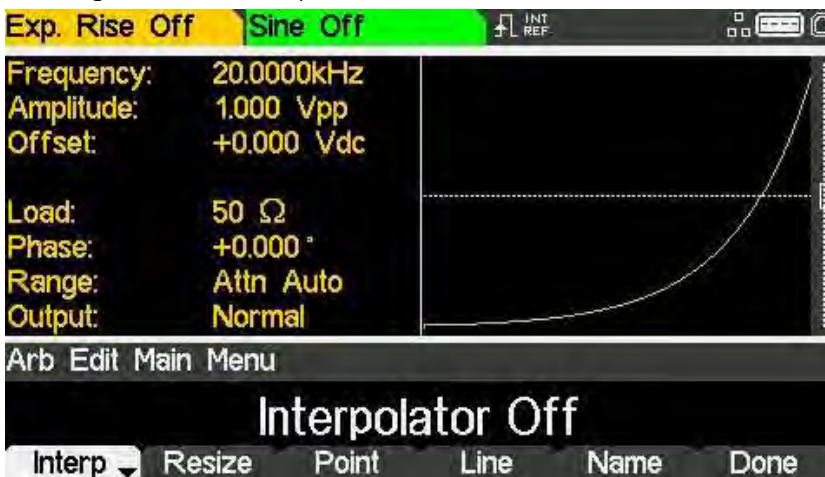

While editing an arbitrary waveform, if the same arbitrary waveform is also currently selected to be the output, then the changes made to the arbitrary waveform can be observed in real time. The waveform will be available at the MAIN OUT connector of the selected channel for display on an oscilloscope. There will also be a representation shown in the Graph Box.



## 22 - Editing Arbitrary Waveforms

Editing an arbitrary waveform

### Editing an arbitrary waveform

There are five editing options for arbitrary waveforms.

#### Interpolation

Interpolation is toggled on and off by the **Interp** soft-key. Although the instrument can handle arbitrary waveforms of any length, they are always played back using DDS. This requires that they must be forced to a suitable length. The instrument can play a waveform of 8192 (8k) points. If a waveform is less than or equal to 8k points it will be played back using 8k points. So, in order to play the waveform, it may be necessary to expand it.

This expansion may be performed in 2 possible ways. Either the extra points may be created by repeating the same points or linear interpolation may be used.

The **Interp** soft-key allows the type of expansion to be specified. With **Interpolator Off** selected points will be repeated, this is most appropriate for waveforms with fast rising or falling edges.

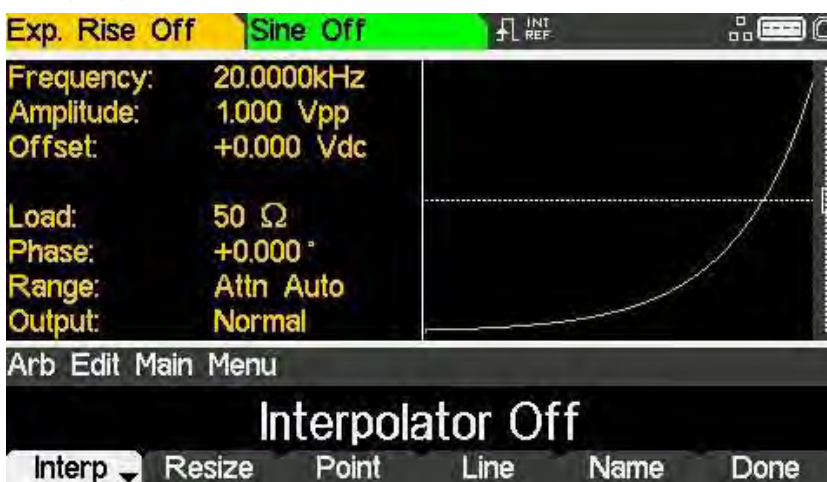

With **Interpolator On** selected linear interpolation will be used as points are added, this is most appropriate for waveforms which are more sinusoidal in nature.



#### NOTE



For a truly complex waveform it should be created with 8k points so that expansion is not required.

## 22 - Editing Arbitrary Waveforms

### Editing an arbitrary waveform

#### Resizing a waveform

A waveform may have its length changed by using the resize option. When a waveform is increased in size new points are added between existing points. The way that the values of these new points are calculated depends on the resize method setting. When a waveform is reduced in size points are simply dropped to achieve the new length.

Pressing the **Resize** soft-key will show the resize menu in the Edit Box and the soft-keys will show the resize options.



The **No.Pts** soft-key allows the new size to be specified. Press the **Execute** soft-key to resize the waveform and return to the top-level edit menu. Pressing the **↩** soft-key will return without resizing.

Pressing the **Method** soft-key will allow the resize method to be set.

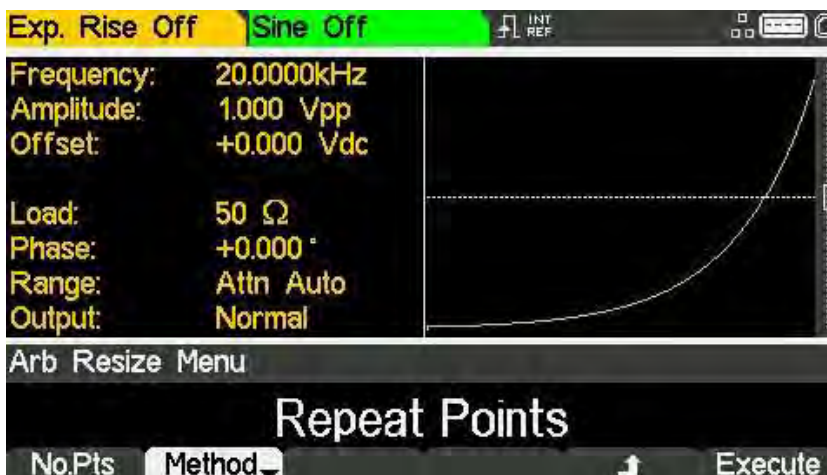

When a waveform is increased in size new points are added between existing points. The way that the values of these new points are calculated depends on the resize method setting. The **Repeat Points** method adds points of the same value as the original point in the waveform. The **Interpolate** method draws a straight line between the existing points.

When a waveform is reduced in size points are simply dropped to achieve the new length and the resize method setting has no effect. Press the **Execute** soft-key to set the waveform and return to the top-level edit menu

## 22 - Editing Arbitrary Waveforms

### Editing an arbitrary waveform

#### Point editing

Pressing the Point soft-key shows the point edit menu in the Edit Box.



The point edit menu allows individual points in the waveform to be set to any vertical level value. The **Point#** soft-key selects setting of the point number; pressing the **Value** soft-key then enables the value to be changed.

#### NOTE



The point value is changed in the actual waveform immediately after it is edited.

## 22 - Editing Arbitrary Waveforms

### Editing an arbitrary waveform

#### Line drawing

Pressing the **Line** soft-key shows the line edit menu in the Edit Box.

The Line edit menu allows a line to be drawn between any two points in the waveform. The end points of the line may be set to any vertical level value.

The **PointA** soft-key selects setting of the first point number; pressing the **ValueA** soft-key then enables the value to be changed.



The **PointB** and **ValueB** soft-keys are used to set the second point. The line is drawn in the actual waveform by pressing the **Execute** soft-key after which the instrument will return to the top-level edit menu.

Pressing the **↩** soft-key will return without drawing the line.

## 22 - Editing Arbitrary Waveforms

### Editing an arbitrary waveform

#### Naming a waveform

Pressing the Name soft-key shows the name edit menu in the Edit Box.



The soft-key labels, KNOB and cursor keys allow the name to be edited.

The **Space** soft-key enters a space character at the cursor position.

The **↕** soft-key cancels the operation and returns to the top-level edit menu.

The **Execute** soft-key changes the name and returns to the top-level edit menu when complete.

The cursor keys will move the edit cursor through the name and turning the KNOB will cycle through all valid characters, numbers and symbols.

Press the **Done** soft-key to exit the edit menu.

## 23 - Calibration

Equipment required

# 23. CALIBRATION

All parameters can be calibrated without opening the case, i.e. the generator offers 'closed-box' calibration. All adjustments are made digitally with calibration constants stored in flash memory. The calibration routine requires only a DVM, power meter and a frequency counter and takes no more than a few minutes.

Calibration should be carried out only after the generator has been operating for at least 30 minutes in normal ambient conditions.

### Equipment required

- 3½ digit DVM with 0.25% DC accuracy and 0.5% AC accuracy at 1kHz.
- Universal counter capable of measuring 10.00000MHz with an accuracy of  $\pm 0.1$ ppm.
- Power meter with frequency range of 10kHz to 240MHz, capable of measuring up to a +5dBm signal with linearity better than 0.1dB

### Calibration procedure

Pressing the UTILITY key followed by the Calib soft-key shows the opening screen for instrument calibration.

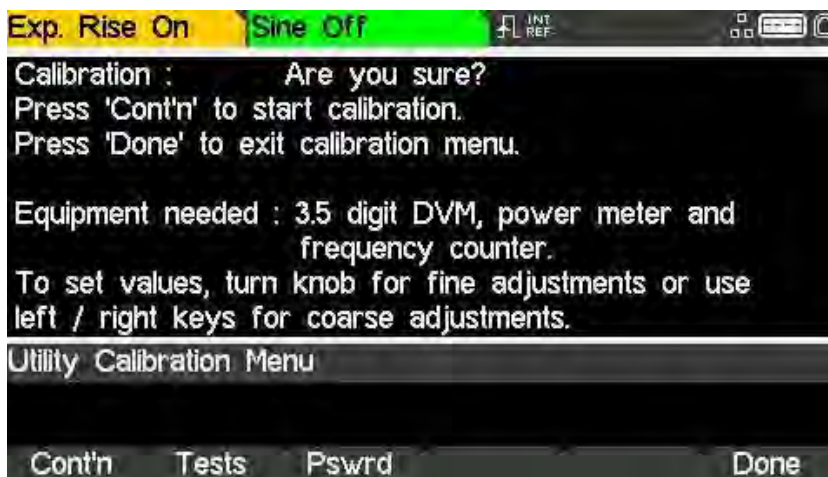

## 23 - Calibration

### Password control

### Password control

The software asks for a 4–digit password in the range 0000 to 9999 to be used to access the calibration procedure. If the password is left at the factory default no messages are shown and calibration can proceed as described in the ‘Calibration routine’ section.

#### NOTE



Factory default password for calibration is 0000. only if a non-zero password has been set will the user be prompted to enter the password.

### Setting the Password

On opening the Calibration screen press the **Pswrd** soft-key to show the password screen.

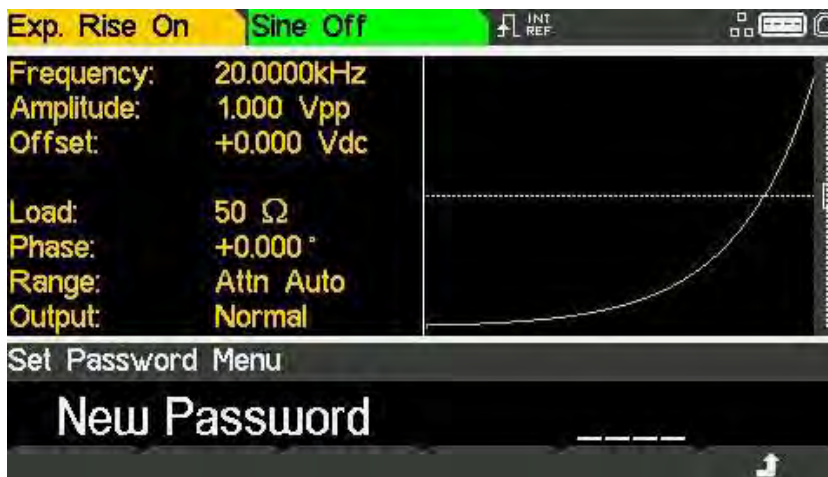

Enter a 4–digit password from the keyboard; the Edit Box will show the message Confirm. Re-enter the password and the message **new password stored** will pop up for two seconds before returning to the top-level calibration menu.

## 23 - Calibration

### Password control

Using the password to access calibration or change the password

With the password set, pressing **Calib** on the utility screen will now show:

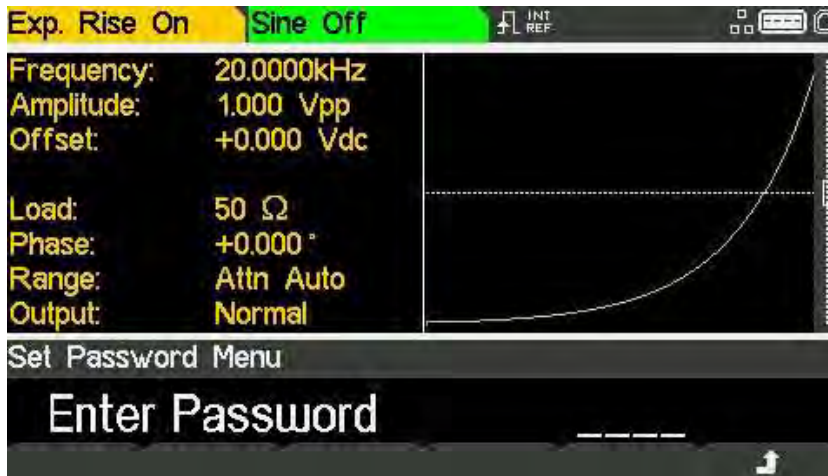

When the correct password has been entered from the keyboard the display changes to the opening screen of the calibration routine and calibration can proceed as described in the Calibration Routine section. If an incorrect password is entered the message **Incorrect Password Please Try Again** will pop up for two seconds before the display reverts to the Utility menu.

With the opening screen of the calibration routine displayed after correctly entering the password, the password can be changed by pressing the **Pswrd** soft-key and following the procedure described in 'Setting the Password'.

### NOTE



If the password is set to 0000 again, password protection is removed.

---

The password is held in flash memory and will not be lost when the memory battery backup is lost.

### NOTE



In the event of the password being forgotten, contact the manufacturer for help in resetting the instrument.

---



## 23 - Calibration

### Calibration routine

#### Calibration routine

The calibration procedure proper is entered by pressing **Cont'n** on the top-level Calibration menu; pressing **Done** returns the display to the Utility menu. Pressing **Tests** calls a menu of basic hardware checks used at production test.

At each calibration step the display changes to prompt the user to adjust the KNOB or cursor keys, until the reading on the specified instrument is at the value given. The cursor keys provide coarse adjustment, and the KNOB fine adjustment. Pressing **➡** increments the procedure to the next step; pressing **⬅** decrements back to the previous step. Alternatively, pressing **Cancel** returns the display to the final calibration screen at which the user can choose to either **Save**, **Recall** or **Restart**.

Each calibration step allows a calibration value to be calibrated. The screen messages specify the instrument to use for measurement, the connector to connect it to, the value to adjust for and the method of adjustment

The full procedure is as follows:

STEP 1	CH1 DC offset zero	Adjust for $0V \pm 5mV$	
STEP 2	CH1 DC offset at + full scale	Adjust for $+ 10V \pm 10mV$	
STEP 3	CH1 DC offset at – full scale	Check for $-10V \pm 50mV$	
STEP 4	CH1 output level at full scale	Adjust for $10V \pm 10mV$	
STEP 5	CH1 6dB attenuation	Adjust for $5V \pm 5mV$	
STEP 6	CH1 12dB attenuation	Adjust for $2.5V \pm 3mV$	
STEP 7	CH1 18dB attenuation	Adjust for $1.25V \pm 3mV$	
STEP 8	CH1 24dB attenuation	Adjust for $625mV \pm 3mV$	
STEP 9	CH1 30dB attenuation	Adjust for $312.5mV \pm 3mV$	
STEP 10	CH1 36dB attenuation	Adjust for $156.25mV \pm 3mV$	
STEP 11	CH1 42dB attenuation	Adjust for $78.125mV \pm 3mV$	
STEP 12	CH1 output level at full scale (filter 2)	Adjust for $10V \pm 10mV$	TGF4162 and TGF4242
STEP 13	CH1 6dB attenuation (filter 2)	Adjust for $5V \pm 5mV$	TGF4162 and TGF4242
STEP 14	CH1 12dB attenuation (filter 2)	Adjust for $2.5V \pm 3mV$	TGF4162 and TGF4242
STEP 15	CH1 18dB attenuation (filter 2)	Adjust for $1.25V \pm 3mV$	TGF4162 and TGF4242
STEP 16	CH1 24dB attenuation (filter 2)	Adjust for $625mV \pm 3mV$	TGF4162 and TGF4242
STEP 17	CH1 30dB attenuation (filter 2)	Adjust for $312.5mV \pm 3mV$	TGF4162 and TGF4242
STEP 18	CH1 36dB attenuation (filter 2)	Adjust for $156.25mV \pm 3mV$	TGF4162 and TGF4242
STEP 19	CH1 42dB attenuation (filter 2)	Adjust for $78.125mV \pm 3mV$	TGF4162 and TGF4242
STEP 20	CH1 Sine amplitude flatness	Note reading	
STEP 21	CH1 level 200kHz	Adjust for same reading	
STEP 22	CH1 Level 10MHz	Adjust for same reading	
STEP 23	CH1 Level 40MHz	Adjust for same reading	TGF4162 and TGF4242
STEP 24	CH1 Level 50MHz	Adjust for same reading	TGF4082, TGF4162 and TGF4242
STEP 25	CH1 Level 90MHz	Adjust for same reading	TGF4082, TGF4162 and TGF4242
STEP 26	CH1 Level 100MHz	Adjust for same reading	TGF4162 and TGF4242
STEP 27	CH1 Level 125MHz	Adjust for same reading	TGF4162 and TGF4242
STEP 28	CH1 Level 135MHz	Adjust for same reading	TGF4162 and TGF4242
STEP 29	CH1 Level 145MHz	Adjust for same reading	TGF4162 and TGF4242
STEP 30	CH1 Level 160MHz	Adjust for same reading	TGF4162 and TGF4242
STEP 31	CH1 Level 200MHz	Adjust for same reading	TGF4242

## 23 - Calibration

### Calibration routine

STEP 32	CH1 Level 240MHz	Adjust for same reading	TGF4242
STEP 33	CH2 DC offset zero	Adjust for $0V \pm 5mV$	
STEP 34	CH2 DC offset at + full scale	Adjust for $+10V \pm 10mV$	
STEP 35	CH2 DC offset at – full scale	Check for $-10V \pm 50mV$	
STEP 36	CH2 output level at full scale	Adjust for $10V \pm 10mV$	
STEP 37	CH2 6dB attenuation	Adjust for $5V \pm 5mV$	
STEP 38	CH2 12dB attenuation	Adjust for $2.5V \pm 3mV$	
STEP 39	CH2 18dB attenuation	Adjust for $1.25V \pm 3mV$	
STEP 40	CH2 24dB attenuation	Adjust for $625mV \pm 3mV$	
STEP 41	CH2 30dB attenuation	Adjust for $312.5mV \pm 3mV$	
STEP 42	CH2 36dB attenuation	Adjust for $156.25mV \pm 3mV$	
STEP 43	CH2 42dB attenuation	Adjust for $78.125mV \pm 3mV$	
STEP 44	CH2 output level at full scale (filter 2)	Adjust for $10V \pm 10mV$	TGF4162 and TGF4242
STEP 45	CH2 6dB attenuation (filter 2)	Adjust for $5V \pm 5mV$	TGF4162 and TGF4242
STEP 46	CH2 12dB attenuation (filter 2)	Adjust for $2.5V \pm 3mV$	TGF4162 and TGF4242
STEP 47	CH2 18dB attenuation (filter 2)	Adjust for $1.25V \pm 3mV$	TGF4162 and TGF4242
STEP 48	CH2 24dB attenuation (filter 2)	Adjust for $625mV \pm 3mV$	TGF4162 and TGF4242
STEP 49	CH2 30dB attenuation (filter 2)	Adjust for $312.5mV \pm 3mV$	TGF4162 and TGF4242
STEP 50	CH2 36dB attenuation (filter 2)	Adjust for $156.25mV \pm 3mV$	TGF4162 and TGF4242
STEP 51	CH2 42dB attenuation (filter 2)	Adjust for $78.125mV \pm 3mV$	TGF4162 and TGF4242
STEP 52	CH2 Sine amplitude flatness	Note reading	
STEP 53	CH2 level 200kHz	Adjust for same reading	
STEP 54	CH2 Level 10MHz	Adjust for same reading	
STEP 55	CH2 Level 40MHz	Adjust for same reading	
STEP 56	CH2 Level 50MHz	Adjust for same reading	TGF4082, TGF4162 and TGF4242
STEP 57	CH2 Level 80MHz	Adjust for same reading	TGF4082, TGF4162 and TGF4242
STEP 58	CH2 Level 100MHz	Adjust for same reading	TGF4162 and TGF4242
STEP 59	CH2 Level 125MHz	Adjust for same reading	TGF4162 and TGF4242
STEP 60	CH2 Level 135MHz	Adjust for same reading	TGF4162 and TGF4242
STEP 61	CH2 Level 145MHz	Adjust for same reading	TGF4162 and TGF4242
STEP 62	CH2 Level 160MHz	Adjust for same reading	TGF4162 and TGF4242
STEP 63	CH2 Level 200MHz	Adjust for same reading	TGF4242
STEP 64	CH2 Level 240MHz	Adjust for same reading	TGF4242
STEP 65	MOD offset	Adjust for $5V \pm 50mV$	
STEP 66	MOD full scale	Adjust for $8V \pm 50mV$	
STEP 67	Ref clock calibration	Adjust for $10.00000\text{ MHz} \pm 1\text{ppm}$	

## 23 - Calibration

### Remote calibration

---

#### Remote calibration

Calibration of the instrument may be performed over the LAN, USB or GPIB interface. To completely automate the process, the multimeter, power meter and universal counter will also need to be remote controlled and the controller will need to run a calibration program unique to this instrument.

The remote calibration commands allow a simplified version of manual calibration to be performed by issuing commands from the controller. The controller must send the CALADJ command repeatedly and read the DVM, power meter or frequency meter until the required result for the selected calibration step is achieved. The CALSTEP command is then issued to accept the new value and move to the next step.

While in remote calibration mode very little error checking is performed and it is the controller's responsibility to ensure that everything progresses in an orderly way. Only the following commands should be used during calibration.

#### CAUTION



Using any other commands while in calibration mode may give unpredictable results and could cause the instrument to lock up, requiring the power to be cycled to regain control.

---

#### CALIBRATION <cpd>, [nr1]:

The calibration control command. <cpd> can be one of three sub-commands:

- START - Enter calibration mode; this command must be issued before any other calibration commands will be recognised.
- SAVE - Finish calibration, save the new values and exit calibration mode.
- ABORT - Finish calibration, do not save the new values and exit calibration mode.

[nr1] represents the 4-digit calibration password. The password is only required with CALIBRATION START and then only if a non-zero password has been set from the instrument's keyboard. The password will be ignored, and will give no errors, at all other times.

#### NOTE



It is not possible to set or change the password using remote commands.

---

**CALADJ <nr1>** Adjust the selected calibration value by <nr1>. The value must be in the range -100 to +100. Once an adjustment has been completed and the new value is as required the CALSTEP command must be issued for the new value to be accepted.

**CALSTEP** Step to the next calibration point.

For general information on remote operation and command formats, refer to the following remote sections.

## 24 - Remote operation

Overview

# 24. REMOTE OPERATION

## Overview

The instrument can be remotely controlled via its USB, LAN or (optional) GPIB interfaces.

USB remote control operates in a similar way to an RS232 interface but via the USB connector.

Software supplied with the instrument sets up the controlling computer to treat the USB connection as a virtual COM port.

Application software on the computer can then access the instrument via that COM port.

The LAN interface is designed to meet 1.5 LXI Device Specification 2016.

Remote control using the LAN interface is possible using the TCP/IP Sockets protocol. The instrument also contains a basic Web server which provides information on the instrument and allows it to be configured from a web browser. Simple command line control from the browser is also possible.

The instrument is supplied with USB and LAN as standard; GPIB is an option. All interfaces are live at initial power up but access to individual interfaces may be restricted using the menus on the front panel or the configuration options on the web pages. To control the restriction of interfaces from the front panel select UTILITY, then the I/O soft-key to show the screen below.



The default is for all available interfaces to be enabled as shown. The **REM IF** soft-key may be used to select the interfaces required. Pressing the **REM IF** key will cycle round the possibilities, in this case:

- Enabled – TCP, USB
- Enabled – TCP Only
- Enabled – USB Only

TCP is used instead of LAN because the LAN itself is not disabled and could still be used to access the instrument web server, Disabling TCP does, however, disable the web page command line control of the instrument.

## 24 - Remote operation

### Address selection

The web page access may also be disabled independently by pressing the Web soft-key. Alternate presses will produce

- Enabled – WEBPAGE
- Disabled – WEBPAGE

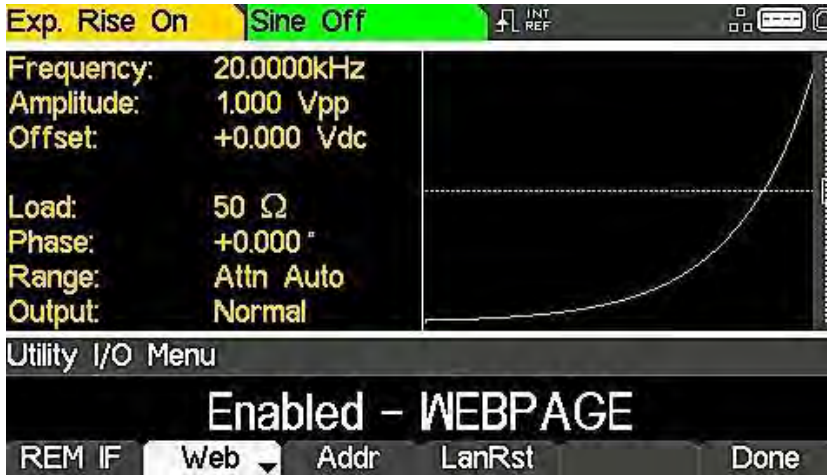

### Address selection

The instrument address capability is strictly required only by the GPIB interface. However, use can be made of the ADDRESS? command over any of the interfaces to easily identify which instrument is being controlled by a particular COM port (for USB) or TCP socket (for LAN).

#### NOTE



The LAN interface also has a separate 'Identify' function, accessible from the instrument's web pages, that flashes the instrument's display until the function is cancelled.

The address is set from the instrument's front panel or web pages. To set the address from the front panel press the **Addr** soft-key on the Utility-I/O menu which will show the following.



## 24 - Remote operation

Remote/ local operation

---

### Remote/ local operation

At power-on the instrument will be in the local state so the REM indicator is not displayed on the Status Line. In this state, all front panel operations are possible.

When the instrument receives a command from an interface the remote state will be entered and the REM indicator will be displayed on the Status Line. In this state the front panel is locked out and remote commands only will be processed.

The instrument may be returned to the local state by pressing the LOCAL key; however, the effect of this action will only remain until the instrument receives another character from the interface, when the remote state will once again be entered. Returning to Local by this action will keep the settings at their last remotely set values.

### USB interface

Using the USB interface for remote control requires a Communications Device Class driver on the PC to provide a virtual COM port instance. In Windows a suitable driver is provided by Microsoft, but it is not installed by default. The data (.INF) file to control the installation is provided on the website: [www.aimtti.com](http://www.aimtti.com)

#### NOTE



The same driver is also used by many other instruments from this manufacturer and may already be known to the PC.

---

## 24 - Remote operation

Installing USB driver for the first time

### Installing USB driver for the first time

To install the driver for the first time:

- First switch the unit on
- Then connect the USB port to the PC.

#### NOTE



In Windows 10, the driver is automatically installed by the operating system.

The Windows plug and play functions should automatically recognise the attachment of new hardware to the USB interface and (possibly after searching the internet for some time) prompt for the location of a suitable driver. Follow the Windows prompts and point to the CD, then the sub-directory for this product, and then to the USB Driver sub-directory below that. The file is named USB\_ARM\_VCP\_xxx.INF, where xxx is a version number. A readme.pdf file will also be found in that directory if further assistance is needed.

In some cases, Windows will not complete this procedure (especially recent versions which search the internet first, looking for the unique Vendor ID and Product ID), in which case the instrument will show in Device Manager as “not working properly”. If this happens, select this device, right click and choose “update driver software...” and then “browse this computer for driver software...” and then locate the .INF file on the CD as described above.

Once Windows has installed the device driver it will assign a COM port number to this particular unit. This number will depend on previous COM port assignments on this PC, and it may be necessary to use Device Manager to discover it. Each instrument has a unique USB identifier which is remembered by the system, so it will receive the same COM port number whenever it is attached to the same PC (regardless of the physical interface socket used), even though the COM port will disappear while the instrument is disconnected or switched off. Other instruments will receive different COM port numbers.

#### NOTE



A different PC will not necessarily assign the same COM port number to a particular instrument (it depends on the history of installations) Device Manager can be used to change the assignments given.

This virtual COM port can be driven by Windows applications (including a terminal emulator) in exactly the same way as any standard COM port, except that the Baud rate and other settings are unnecessary and are ignored. Some old applications might not function with COM port numbers 3 or 4, or above 9. In this case, use Device Manager to change the allocation given. Once it is installed, the driver will be maintained by Windows Update in the usual way.

## 24 - Remote operation

### LAN interface

---

#### LAN interface

The LAN interface is designed to comply with the LXI standard version 1.5 LXI Device Specification 2016 and contains the interfaces and protocols described below.

Since it is possible to misconfigure the LAN interface, making it impossible to communicate with the instrument over LAN, a LAN Configuration Initialise (LCI) mechanism is provided via the menus from the front panel to reset the instrument's interfaces to the factory default. The default setting is for the instrument to attempt to obtain settings via DHCP if available or, if DHCP times out (30 seconds), via Auto-IP.

In the very unlikely event that an Auto-IP address cannot be found a static IP address of 192.168.1.100 is assigned. Resetting the LAN removes any password protection which has been set on the web page.

To reset the LAN interface, press the **LanRst** soft-key on the Utility-I/O menu.

For more information on LXI standards refer to [www.lxistandard.org](http://www.lxistandard.org)

#### LAN connection



To use the LAN interface, the IP address of the unit must be known. A guide to the LXI Discovery Tool which provides links to the latest version of the tool and associated downloads, can be found on the website: [www.aimtti.com](http://www.aimtti.com). The tool is a Windows PC application which can be used to display the IP addresses or host names of all connected devices that comply with the VXI-11 protocol or support multicast Domain Name System (mDNS) records.

Connecting via a router is recommended as this is significantly quicker to assign an IP address; connecting directly to the PC will begin to assign an IP address only after a 30 second DHCP time-out. Double clicking on any entry in the list of devices discovered will open the PC's web browser and display the Home page of that device.

There are also tools for LAN discovery included as part of the National Instruments Measurement and Automation Explorer package and the Keysight (formerly Agilent) Vee application.

It is also possible to discover the assigned IP address from the Help menu:

- Press the **UTILITY** key
- followed by the **Help** soft-key
- then select **option 3**
- scroll down to the IP address.

The unit will, when first powered up, attempt to obtain settings via DHCP if available or, if DHCP times out (30 seconds), via Auto-IP. In the very unlikely event that an Auto-IP address cannot be found a static IP address of 192.168.1.100 is assigned. During this time the LAN indicator will keep flashing and change to  if a LAN connection is successfully made. However, if a connection is still not made by the end of the above process, or if the LAN connector is physically removed at any time, the LAN field in the status line will change to ; see 'LAN error' section for details.



## 24 - Remote operation

LAN connection

---

### Web server; configuration password protection

The unit contains a basic web server. This provides information on the instrument and allows it to be configured. The Configure page can be password protected to deter unauthorised changes to the remote operation configuration.

#### NOTE



The default configuration page password is blank (no password).

---

The Configure page itself explains how to set the password. The password can be up to 15 characters long; the User Name should be left blank. The password will, however, be reset to the default (no password) if the front panel is used to reset all the LAN parameters to their factory default.

The web pages also have an 'Identify' function which allows the user to send an identifying command to the instrument which causes its display status line to flash until the command is cancelled.

## 24 - Remote operation

### LAN connection

---

#### ICMP ping server

The unit contains an ICMP server allowing the instrument to be 'pinged' via either its host name or IP address.

#### VXI-11 discovery protocol

The instrument has very limited support of VXI-11 which is sufficient for the discovery protocol and no more.

The instrument implements a Sun RPC Port-mapper on TCP port 111 and UDP port 111 as defined in RPC1183. The calls supported are: NULL, GET PORT and DUMP.

On TCP port 1024 a very simple VXI-11 protocol is implemented sufficient only for instrument discovery. This implements the following calls: CREATE LINK, DEVICE\_WRITE, DEVICE\_READ and DESTROY\_LINK.

Once a link has been created anything written to the device is ignored and any read from the device returns the identification string as would be expected from a `"*IDN?"` command of the form

#### Manufacturer, Model, Serial No., XX.xx – YY.yy – ZZ.zz

where 'XX.xx' is the revision of the main firmware and 'YY.yy' is the revision of the remote interface firmware and 'ZZ.zz' is the revision of the USB flash drive firmware.

#### mDNS and DNS-SD support

Multicast DNS provides DNS services even on networks without a central DNS server (or DHCP server). This simplifies the setting up of a simple LAN using meaningful hostnames instead of a raw IP address. With service discovery it becomes straightforward for the device to be discovered and the services it provides.

The services provided by the instrument are `http (_http._tcp)` and `lxi (_lxi._tcp)`.

#### VISA resource name

Because of the limited support for VXI-11(Discovery Protocol only), the instrument must be referred to by its raw socket information when used in software packages which communicate via a VISA resource name. For example, an instrument at IP address 192.168.1.100 would normally have a VISA resource name of `"TCPIP0::192.168.1.100::inst0::INSTR"` but for this instrument the name must be modified to read `"TCPIP0::192.168.1.100::9221::SOCKET"` where 9221 is the TCP port used by this instrument for control and monitoring.

#### XML identification document URL

As required by the LXI Standard, the instrument provides an XML identification document that can be queried via a GET at `"http://<hostname>:80/lxi/identification"` that conforms to the LXI XSD Schema (available at <http://www.lxistandard.org/InstrumentIdentification/1.0>) and the W3C XML Schema Standards ( <http://www.w3.org/XML/Schema> ). This document describes the instrument.

#### TCP sockets

The instrument uses 1 socket on TCP port 9221 for instrument control and monitoring. Text commands are sent to this port as defined in 'Remote Commands' and any replies are returned via the same port. Commands may be separated with either semicolons `“;”` or line feeds.

## 24 - Remote operation

### LAN connection

---





#### LAN error

If a LAN connection is made but an error is detected (e.g. the IP address is the same as another device on the network) then the LAN field in the status line will show  until the error is corrected.

If a LAN error occurs; check and correct the configuration of the instrument; To reset the LAN interface press the **LanRst** soft-key on the UTILITY-I/O menu. The default setting is for the instrument to attempt to obtain settings via DHCP if available or, if DHCP times out (30 seconds), via Auto-IP. In the very unlikely event that an Auto-IP address cannot be found a static IP address of 192.168.1.100 is assigned. If no physical LAN connection is found at any time the LAN field in the status line will show .

#### LAN status indication

The LAN field in the Status Line can show multiple status indications:

-  There is no LAN connection, for example no cable connected. When the system is attempting to connect the icon will flash.
-  Successfully connected with remote control enabled.
-  Connected but remote control is disabled.
-  Unsuccessful attempt to connect.

## 24 - Remote operation

### GPIB interface

---

#### GPIB interface

The GPIB interface 24-way connector is located on the instrument rear panel. The pin connections are as specified in IEEE Std. 488.1-1987 and the instruments in the range complies with IEEE Std. 488.1-1987 and IEEE Std. 488.2-1987 and contain the following IEEE 488.1 subsets.

#### GPIB subsets

This instrument contains the following IEEE 488.1 subsets:

Source Handshake	SH1
Acceptor Handshake	AH1
Talker	T6
Listener	L4
Service Request	SR1
Remote Local	RL2
Parallel Poll	PP1
Device Clear	DC1
Device Trigger	DT0
Controller	C0
Electrical Interface	E2

#### GPIB IEEE Std. 488.2 error handling – Query error register

The IEEE 488.2 UNTERMINATED error (addressed to talk with nothing to say) is handled as follows. If the instrument is addressed to talk and the response formatter is inactive and the input queue is empty then the UNTERMINATED error is generated. This will cause the Query Error bit to be set in the Standard Event Status Register, a value of 3 to be placed in the Query Error Register and the parser to be reset. See 'Status reporting' section for further information.

The IEEE 488.2 INTERRUPTED error is handled as follows. If the response formatter is waiting to send a response message and a <PROGRAM MESSAGE TERMINATOR> has been read by the parser or the input queue contains more than one END message then the instrument has been INTERRUPTED and an error is generated. This will cause the Query Error bit to be set in the Standard Event Status Register, a value of 1 to be placed in the Query Error Register and the response formatter to be reset thus clearing the output queue. The parser will then start parsing the next <PROGRAM MESSAGE UNIT> from the input queue. See 'Status reporting' section for further information.

The IEEE 488.2 DEADLOCK error is handled as follows. If the response formatter is waiting to send a response message and the input queue becomes full then the instrument enters the DEADLOCK state and an error is generated. This will cause the Query Error bit to be set in the Standard Event Status Register, a value of 2 to be placed in the Query Error Register and the response formatter to be reset thus clearing the output queue. The parser will then start parsing the next <PROGRAM MESSAGE UNIT> from the input queue. See 'Status reporting' section for further information.

## 24 - Remote operation

### GPIB interface

#### GPIB parallel poll

Complete parallel poll capabilities are offered on this instrument. The Parallel Poll Enable Register is set to specify which bits in the Status Byte Register are to be used to form the *ist* local message. The Parallel Poll Enable Register is set by the `*PRE <nrf>` command and read by the `*PRE?` command. The value in the Parallel Poll Enable Register is ANDed with the Status Byte Register; if the result is zero then the value of *ist* is 0 otherwise the value of *ist* is 1.

The instrument must also be configured so that the value of *ist* can be returned to the controller during a parallel poll operation. The instrument is configured by the controller sending a Parallel Poll Configure command (PPC) followed by a Parallel Poll Enable command (PPE). The bits in the PPE command are shown in the following table:

Bit 7 =	X	don't care
Bit 6 =	1	Parallel poll enable
Bit 5 =	1	
Bit 4 =	0	
Bit 3 =	Sense	sense of the response bit; 0 = low, 1 = high
Bit 2 =	?	bit position of the response
Bit 1 =	?	
Bit 0 =	?	

#### EXAMPLE



To return the RQS bit (bit 6 of the Status Byte Register) as a 1 when true and a 0 when false in bit position 1 in response to a parallel poll operation send the following commands

**`*PRE 64<pmt>`, then PPC followed by 69H (PPE)**

The parallel poll response from the instrument will then be 00H if RQS is 0 and 01H if RQS is 1.

During parallel poll response the DIO interface lines are resistively terminated (passive termination). This allows multiple devices to share the same response bit position in either wired-AND or wired-OR configuration, see 'GPIB interface' for more information.

## 24 - Remote operation

### Status reporting

---

#### Status reporting

A separate error and status model is maintained for each interface instance; an interface instance is defined as a potential connection. USB and GPIB are inherently single connections so represent one interface instance each. LAN, however, allows for multiple simultaneous connections and therefore represents multiple interface instances. One interface instance is allocated to the TCP socket interface and one more is allocated to the Web page interface. Having a separate model for each interface instance ensures that data does not get lost as many commands e.g. '\*ESR?' clear the contents on read. Error status is maintained using a set of registers; these are described in the following paragraphs and shown on the Status Model at the end of this section.

#### Standard event status and standard event status enable registers

These two registers are implemented as required by the IEEE Std. 488.2.

Any bits set in the Standard Event Status Register which correspond to bits set in the Standard Event Status Enable Register will cause the ESB bit to be set in the Status Byte Register.

The Standard Event Status Register is read and cleared by the '\*ESR?' command. The Standard Event Status Enable register is set by the '\*ESE <nrf>' command and read by the '\*ESE?' command.

It is a bit field where each bit has the following significance.

- Bit 7: Power On. Set when power is first applied to the instrument.
- Bit 6: User Request (Not used).
- Bit 5: Command Error. Set when a syntax type error is detected in a command from the bus. The parser is reset and parsing continues at the next byte in the input stream
- Bit 4: Execution Error. Set when an error is encountered while attempting to execute a completely parsed command. The appropriate error number will be reported in the Execution Error Register, see 'Error messages' section
- Bit 3: Not used.
- Bit 2: Query Error. Set when a query occurs. The appropriate error number will be reported in the Query Error Register, see 'Error messages' section.
- Bit 1: Not used.
- Bit 0: Operation Complete: Set in response to the '\*OPC' command.

#### Execution error register

This register contains a number representing the last error encountered over the current interface. The Execution Error Register is read and cleared using the 'EER?' command. On power up this register is set to 0 for all interface instances.

#### Status byte register and service request enable register

These two registers are implemented as required by the IEEE STD. 488.2.

Any bits set in the Status Byte Register which correspond to bits set in the Service Request Enable Register will cause the RQS/MSS bit to be set in the Status Byte Register, thus generating a Service Request on the bus.

The Status Byte Register is read either by the '\*STB?' command, which will return MSS in bit 6, or by a Serial Poll which will return RQS in bit 6. The Service Request Enable register is set by the '\*SRE <nrf>' command and read by the '\*SRE?' command.

## 24 - Remote operation

### Status reporting

- Bit 7: Not used.
- Bit 6: RQS/MSS. This bit, as defined by IEEE Std. 488.2, contains both the Requesting Service message and the Master Status Summary message. RQS is returned in response to a Serial Poll and MSS is returned in response to the \*STB? command.
- Bit 5: ESB. The Event Status Bit. This bit is set if any bits set in the Standard Event Status Register correspond to bits set in the Standard Event Status Enable Register.
- Bit 4: MAV. The Message Available Bit. This will be set when the instrument has a response message formatted and ready to send to the controller. The bit will be cleared after the Response Message Terminator has been sent.
- Bit 3: Not used.
- Bit 2: Not used.
- Bit 1: Not used
- Bit 0: Not used

### Status model

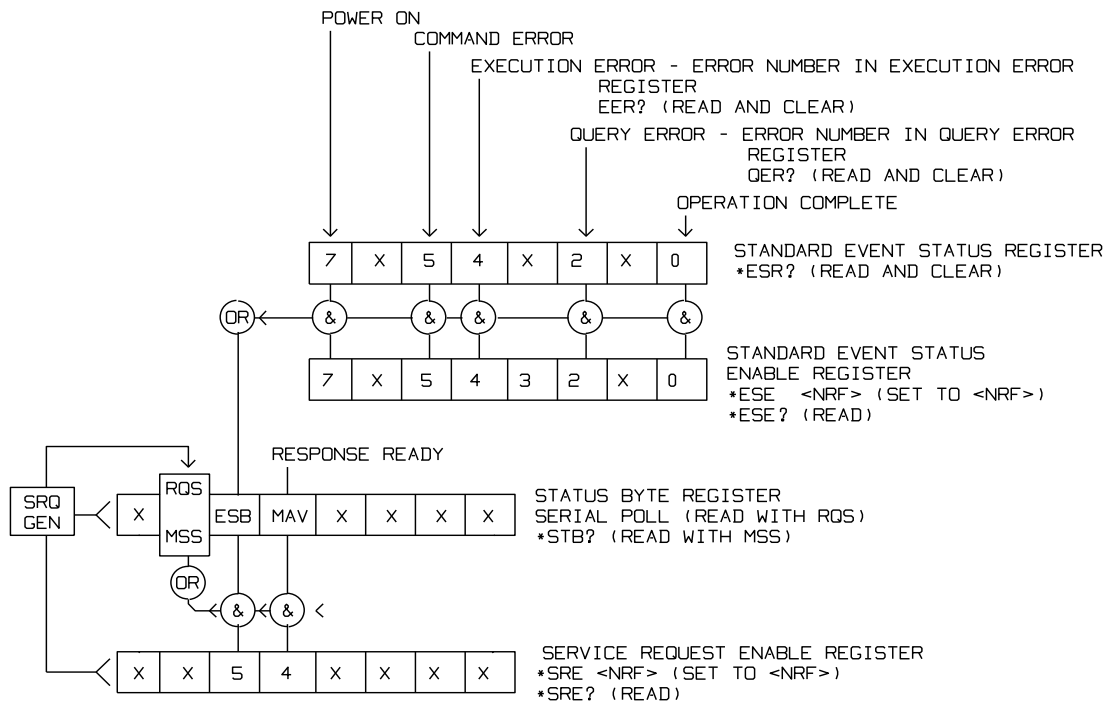

## 24 - Remote operation

### Status reporting

---

#### Power-on and remote operation default settings

The following instrument status values are set at power on:

- Status Byte Register = 0
- Service Request Enable Register † = 0
- Standard Event Status Register = 128 (pon bit set)
- Standard Event Status Enable Register † = 0
- Execution Error Register = 0
- Query Error Register = 0
- Parallel Poll Enable Register † = 0

† Registers marked thus are specific to the GPIB section of the instrument and are of limited use via other interfaces.

The instrument will be in local state with the front panel controls active.

The instrument parameters at power-on are always the same as at last switch off with the exception of the output status. By default, the output is always off at power on but the user may change this from the front panel to be the same at power on as it was at switch off, see the Power On State paragraph in the 'Utility Menu' - System section.

The \*RST (reset) interface command resets the instrument to the Remote Operation Default settings.



## 25 - Remote Commands

USB/LAN remote command format

---

# 25. REMOTE COMMANDS

### USB/LAN remote command format

USB input to the instrument is buffered in a 256 byte input queue which is filled, under interrupt, in a manner transparent to all other instrument operations. The USB interface conforms with the USB 2.0 Full Speed.

LAN input to the instrument is buffered in a 1500 byte input queue which is filled, under interrupt, in a manner transparent to all other instrument operations. The LAN interface conforms with the 1.5 LXI Device Specification 2016.

Commands must be sent as specified in the commands list and must be terminated with the command terminator code 0AH (Line Feed, LF). Commands may be sent in groups with individual commands separated from each other by the code 3BH (;). The group must be terminated with command terminator 0AH (Line Feed, LF).

Responses from the instrument to the controller are sent as specified in the commands list. Each response is terminated by a <RESPONSE MESSAGE TERMINATOR> which is 0DH (Carriage Return, CR) followed by 0AH (Line Feed, LF).

<WHITE SPACE> is defined as character codes 00H to 20H inclusive.

<WHITE SPACE> is ignored except in command identifiers. e.g. '\*C LS' is not equivalent to '\*CLS'. The high bit of all characters is ignored. The commands are case insensitive.

## 25 - Remote Commands

### GPIB remote command formats

---

#### GPIB remote command formats

GPIB input to the instrument is buffered in a 256 byte input queue which is filled, under interrupt, in a manner transparent to all other instrument operations. The queue contains raw (un-parsed) data which is taken, by the parser, as required. Commands (and queries) are executed in order and the parser will not start a new command until any previous command or query is complete. There is no output queue which means that the response formatter will wait, indefinitely if necessary, until the instrument is addressed to talk and the complete response message has been sent, before the parser is allowed to start the next command in the input queue.

Commands are sent as <PROGRAM MESSAGES> by the controller, each message consisting of zero or more <PROGRAM MESSAGE UNIT> elements separated by <PROGRAM MESSAGE UNIT SEPARATOR> elements.

A <PROGRAM MESSAGE UNIT> is any of the commands in the remote commands list.

A <PROGRAM MESSAGE UNIT SEPARATOR> is the semi-colon character ';' (3BH).

<PROGRAM MESSAGES> are separated by <PROGRAM MESSAGE TERMINATOR> elements which may be any of the following:

- |        |  |
|--------|--|
| NL     | The new line character (0AH)                           |
| NL^END | The new line character with the END message            |
| ^END   | The END message with the last character of the message |

Responses from the instrument to the controller are sent as <RESPONSE MESSAGES>. A <RESPONSE MESSAGE> consists of one <RESPONSE MESSAGE UNIT> followed by a <RESPONSE MESSAGE TERMINATOR>.

A <RESPONSE MESSAGE TERMINATOR> is the new line character with the END message NL^END.

Each query produces a specific <RESPONSE MESSAGE> which is listed along with the command in the remote commands list.

<WHITE SPACE> is ignored except in command identifiers. e.g. '\*C LS' is not equivalent to '\*CLS'. <WHITE SPACE> is defined as character codes 00H to 20H inclusive with the exception of the NL character (0AH). The high bit of all characters is ignored. The commands are case insensitive.

## 25 - Remote Commands

### Command list

---

## Command list

This section lists all commands and queries implemented in this instrument.

### NOTE



there are no dependent parameters, coupled parameters, overlapping commands, expression program data elements or compound command program headers; each command is completely executed before the next command is started. All commands are sequential and the operation complete message is generated immediately after execution in all cases.

---

The following nomenclature is used:

- <RMT>                      <RESPONSE MESSAGE TERMINATOR>
- <CPD>                      <CHARACTER PROGRAM DATA>, i.e. a short mnemonic or string such as ON or OFF. Multiple CPDs in a command are shown as <CPD1>, <CPD2>, <CPD3>, etc.
- <NRF>                      A number in any format. e.g. 12, 12·00, 1·2 e1 and 120 e-1 are all accepted as the number 12. Any number, when received, is converted to the required precision consistent with the use then rounded to obtain the value of the command.
- <NR1>                      A number with no fractional part, i.e. an integer.
- <CRD>                      <CHARACTER RESPONSE DATA>
- <BIN>                      Binary data as detailed for the particular command.

[..] Any item(s) enclosed in these brackets are optional parameters. If more than one item is enclosed then all or none of the items are required.

The commands which begin with a \* are implemented as specified by IEEE Std 488.2 as Common commands. All will function when used on the other interfaces but some may be of little use.

The Operation Complete bit (bit 0) in the Standard Event Status Register is only ever set by the \*OPC command. The \*OPC (or the \*OPC?) command can be used for device synchronisation due to the sequential nature of remote operations.

## 25 - Remote Commands

### Channel selection

---

#### Channel selection

Most commands act on a particular channel of the generator. The following command is used to select the required channel. Subsequent commands will change only the specified parameter on the selected channel.

- CHN< NR1>                      **Set channel** <NR1> as the **destination** for subsequent commands. <NR1> can be 1 or 2.
- CHN?                              Return currently selected channel number

## 25 - Remote Commands

### Continuous carrier wave commands

---

#### Continuous carrier wave commands

- WAVE <CPD> Set the output waveform **type** to <SINE>, <SQUARE>, <RAMP>, <TRIANG> <PULSE>, <NOISE>, <PRBSPN7>, <PRBSPN9>, <PRBSPN11>, <PRBSPN15>, <PRBSPN20>, <PRBSPN23>, <PRBSPN29>, <PRBSPN31> or <ARB>.
- FREQ <NRF> Set the waveform **frequency** to <NRF> Hz
- PER <NRF> Set the waveform **period** to <NRF> Sec
- AMPLRNG <CPD> Set the **amplitude range** to <AUTO> or <HOLD>
- AMPL <NRF> Set the **amplitude** to <NRF> Vpp
- HILVL <NRF> Set the amplitude **high-level** to <NRF> Volts
- LOLVL <NRF> Set the amplitude **low-level** to <NRF> Volts
- DCOFFS <NRF> Set the **dc offset** to <NRF> Volts
- OUTPUT <CPD> Set the **output** to <ON>, <OFF>, <NORMAL> or <INVERT>
- ZLOAD <CPD> Set the **output load**, which the generator is to assume for amplitude and dc offset entries, to <1..10,000> Ohms or <OPEN>.
- SQRSYMM <NRF> Set the **square waveform symmetry** to <NRF> %
- RMPSYMM <NRF> Set the **ramp waveform symmetry** to <NRF> %
- SYNCOUT <CPD> Set the **sync output** to <ON>, <OFF>
- SYNCTYPE <CPD> Set the **sync type** to <AUTO>, <NORMAL>, <CARRIER>, <TRIGGER> or <OFF>
- CHN2CONFIG <CPD> Set **channel 2 configuration** to <MAINOUT> or <SYNCOUT>.
- PHASE <NRF> Set the waveform **phase** offset to <NRF> degree.
- ALIGN Sends signal to **align zero phase** reference of both channels.

## 25 - Remote Commands

### Pulse generator commands

---

#### Pulse generator commands

- PULSFREQ <NRF>                    **Set** the pulse waveform **frequency** to <NRF> Hz
- PULSPER <NRF>                    **Set** the pulse waveform **period** to <NRF> sec
- PULSWID <NRF>                    **Set** the pulse waveform **width** to <NRF> sec
- PULSSYMM <NRF>                   **Set** the pulse waveform **symmetry** to <NRF> %
- PULSEEDGE <NRF>                   **Set** the pulse waveform **edges** (positive and negative edge) to <NRF> sec
- PULSRISE <NRF>                   **Set** the pulse waveform **positive edge** to <NRF> sec
- PULSFALL <NRF>                   **Set** the pulse waveform **negative edge** to <NRF> sec
- PULSDLY <NRF>                    **Set** the pulse waveform **delay** to <NRF> sec

#### PRBS generator commands

- PRBSBITRATE <NRF>                **Set** the PRBS waveform **bit rate** to <NRF> bits per second.

## 25 - Remote Commands

### Arbitrary waveform commands

---

#### Arbitrary waveform commands

- ARBDCOFFS <NRF>                    **Set** the arbitrary dc waveform **offset** to <NRF> Volts
- ARBFILTER <CPD>                    **Set** the arbitrary waveform **filter shape** to <NORMAL> or <STEP>
- ARBLOAD <CPD>                    **Set** the output waveform **type** to <DC>, <SINC>, <HAVERSINE>, <CARDIAC>, <EXPRISE>, <LOGRISE>, <EXP FALL>, <LOG FALL>, <GAUSSIAN>, <LORENTZ>, <DLORENTZ>, <TRIANG>, <ARB1>, <ARB2>, <ARB3> or <ARB4>. The user specified name of the arbs stored in ARB1, ARB2, ARB3 or ARB4 are also accepted as valid entries to change the waveform to ARB1, ARB2, ARB3 or ARB4 respectively.
- ARBRESIZE <CPD>, <NR1>           **Change** the **size** of arbitrary waveform <CPD> to <NR1>.
- ARBDEF < CPD1>, < CPD2>, < CPD3>   **Define an arbitrary waveform with user specified Waveform name and waveform point interpolation state.**  
< CPD1> ARB1, ARB2, ARB3 or ARB4  
< CPD2> "user specified waveform name"  
< CPD3> waveform point interpolation ON or OFF
- ARB1 <BIN>                    **Load data to an existing arbitrary waveform memory location ARB1.** The data consists of two bytes per point with no characters between bytes or points. The point data is sent high byte first. The data block has a header which consists of the # character followed by several ascii coded numeric characters. The first of these defines the number of ascii characters to follow and these following characters define the length of the binary data in bytes. The instrument will wait for data indefinitely If less data is sent. If more data is sent the extra is processed by the command parser which results in a command error.
- ARB2 <BIN>                    See ARB1 description.
- ARB3 <BIN>                    See ARB1 description.
- ARB4 <BIN>                    See ARB1 description.
- ARB1DEF?                    **Return user specified waveform name, waveform point interpolation state and waveform length of ARB1.**
- ARB2DEF?                    See ARB1DEF? description.
- ARB3DEF?                    See ARB1DEF? description.
- ARB4DEF?                    See ARB1DEF? description.

## 25 - Remote Commands

### Arbitrary waveform commands

---

- ARB1? **Return the data from an existing arbitrary waveform location ARB1.** The data consists of two bytes per point with no characters between bytes or points. The point data is sent high byte first. The data block has a header which consists of the # character followed by several ascii coded numeric characters. The first of these defines the number of ascii characters to follow and these following characters define the length of the binary data in bytes.
- ARB2? See ARB1? description.
- ARB3? See ARB1? description.
- ARB4? See ARB1? description.



## 25 - Remote Commands

### Modulation commands

---

#### Modulation commands

- MOD <CPD> **Set modulation** to <OFF>, <AM>, <AMSC>, <FM>, <PM>, <ASK>, <FSK>, <SUM>, <BPSK> or <PWM>
- MODAMSHAPE <CPD> **Set AM waveform shape** to <SINE>, <SQUARE>, <RAMPUP>, <RAMPDN>, <TRIANG>, <NOISE>, <DC>, <SINC>, <EXPRISE>, <LOGRISE>, <EXPFALL>, <LOGFALL>, <HAVERSINE>, <CARDIAC>, <GAUSSIAN>, <LORENTZ>, <DLORENTZ>, <ARB1>, <ARB2>, <ARB3>, <ARB4>, <PRBSPN7>, <PRBSPN9>, <PRBSPN11>, <PRBSPN15>, <PRBSPN20>, <PRBSPN23>, < PRBSPN29> or < PRBSPN31>
- MODFM SHAPE <CPD> **Set FM waveform shape** to <SINE>, <SQUARE>, <RAMPUP>, <RAMPDN>, <TRIANG>, <NOISE>, <DC>, <SINC>, <EXPRISE>, <LOGRISE>, <EXPFALL>, <LOGFALL>, <HAVERSINE>, <CARDIAC>, <GAUSSIAN>, <LORENTZ>, <DLORENTZ>, <ARB1>, <ARB2>, <ARB3>, <ARB4>, <PRBSPN7>, <PRBSPN9>, <PRBSPN11>, <PRBSPN15>, <PRBSPN20>, <PRBSPN23>, < PRBSPN29> or < PRBSPN31>
- MODPMSHAPE <CPD> **Set PM waveform shape** to <SINE>, <SQUARE>, <RAMPUP>, <RAMPDN>, <TRIANG>, <NOISE>, <DC>, <SINC>, <EXPRISE>, <LOGRISE>, <EXPFALL>, <LOGFALL>, <HAVERSINE>, <CARDIAC>, <GAUSSIAN>, <LORENTZ>, <DLORENTZ>, <ARB1>, <ARB2>, <ARB3>, <ARB4>, <PRBSPN7>, <PRBSPN9>, <PRBSPN11>, <PRBSPN15>, <PRBSPN20>, <PRBSPN23>, < PRBSPN29> or < PRBSPN31>
- MODPWMSHAPE <CPD> **Set PWM waveform shape** to <SINE>, <SQUARE>, <RAMPUP>, <RAMPDN>, <TRIANG>, <NOISE>, <DC>, <SINC>, <EXPRISE>, <LOGRISE>, <EXPFALL>, <LOGFALL>, <HAVERSINE>, <CARDIAC>, <GAUSSIAN>, <LORENTZ>, <DLORENTZ>, <ARB1>, <ARB2>, <ARB3>, <ARB4>, <PRBSPN7>, <PRBSPN9>, <PRBSPN11>, <PRBSPN15>, <PRBSPN20>, <PRBSPN23>, < PRBSPN29> or < PRBSPN31>
- MODSUMSHAPE <CPD> **Set SUM waveform shape** to <SINE>, <SQUARE>, <RAMPUP>, <RAMPDN>, <TRIANG>, <NOISE>, <DC>, <SINC>, <EXPRISE>, <LOGRISE>, <EXPFALL>, <LOGFALL>, <HAVERSINE>, <CARDIAC>, <GAUSSIAN>, <LORENTZ>, <DLORENTZ>, <ARB1>, <ARB2>, <ARB3>, <ARB4>, <PRBSPN7>, <PRBSPN9>, <PRBSPN11>, <PRBSPN15>, <PRBSPN20>, <PRBSPN23>, < PRBSPN29> or < PRBSPN31>
- MODAMSRC <CPD> **Set AM waveform source** to <INT> or <EXT>
- MODFMSRC <CPD> **Set FM waveform source** to <INT> or <EXT>
- MODPMSRC <CPD> **Set PM waveform source** to <INT> or <EXT>

## 25 - Remote Commands

### Modulation commands

---

- MODPWMSRC <CPD>      **Set PWM waveform source** to <INT> or <EXT>
- MODSUMSRC <CPD>      **Set SUM waveform source** to <INT> or <EXT>
- MODAMFREQ <NRF>      **Set AM waveform frequency** to <NRF> Hz
- MODFMFREQ <NRF>      **Set FM waveform frequency** to <NRF> Hz
- MODPMFREQ <NRF>      **Set PM waveform frequency** to <NRF> Hz
- MODPWMFREQ <NRF>      **Set PWM waveform frequency** to <NRF> Hz
- MODSUMFREQ <NRF>      **Set SUM waveform frequency** to <NRF> Hz
- MODAMDEPTH <NRF>      **Set AM waveform depth** to <NRF> %
- MODFMDEV <NRF>      **Set FM waveform deviation** to <NRF> Hz
- MODPMDEV <NRF>      **Set PM waveform deviation** to <NRF> degree
- MODPWMDEV <NRF>      **Set PWM waveform deviation** to <NRF> %
- MODSUMLEVEL <NRF>      **Set SUM waveform level** to <NRF> %
- MODFSKSRC <CPD>      **Set FSK waveform source** to <INT> or <EXT>
- MODHOPFREQ <NRF>      **Set HOP frequency** to <NRF> Hz
- MODFSKRATE <NRF>      **Set FSK rate** to <NRF> Hz
- MODPOLFSK <CPD>      **Set FSK slope** to <POS> or <NEG>
- MODBPSKSRC <CPD>      **Set BPSK waveform source** to <INT> or <EXT>
- MODBPSKPHASE <NRF>      **Set BPSK phase offset** to <NRF> degree
- MODBPSKRATE <NRF>      **Set BPSK rate** to <NRF> Hz
- MODPOLBPSK <CPD>      **Set BPSK slope** to <POS> or <NEG>
- MODASKSRC <CPD>      **Set ASK waveform source** to <INT> or <EXT>
- MODHOPAMPL <NRF>      **Set HOP amplitude** to <NRF> Vpp
- MODASKRATE <NRF>      **Set ASK rate** to <NRF> Hz
- MODPOLASK <CPD>      **Set ASK slope** to <POS> or <NEG>

## 25 - Remote Commands

### Sweep commands

---

#### Sweep commands

- SWPTYPE <CPD>                   **Set** the sweep **type** to <LINUP>, <LINDN>, <LOGUP> or <LOGDN>.
- SWPMODE <CPD>                   **Set** the sweep **mode** to <CONT> or <TRIG>.
- SWPTRGSRC <CPD>               **Set** the sweep **trigger source** to <INT>, <EXT> or <MAN>.
- SWPTRGPER <NRF>               **Set** the sweep **trigger period** to <NRF> Sec.
- SWPTRGPOL <CPD>               **Set** the sweep **trigger slope** to <POS> or <NEG>.
- SWPBEGFREQ <NRF>               **Set** the sweep **start frequency** to <NRF> Hz.
- SWPENDFREQ <NRF>               **Set** the sweep **stop frequency** to <NRF> Hz.
- SWPCNTFREQ <NRF>               **Set** the sweep **centre frequency** to <NRF> Hz.
- SWPSPNFREQ <NRF>               **Set** the sweep **frequency span** to <NRF> Hz.
- SWPTIME <NRF>                   **Set** the sweep **time** to <NRF> sec.
- SWP <CPD>                       **Set** the **sweep** to <ON> or <OFF>.

#### Burst commands

- BSTTRGSRC <CPD>               **Set** the burst **trigger source** to <INT>, <EXT> or <MAN>.
- BSTPER<NRF>                   **Set** the burst **trigger period** to <NRF> Sec.
- BSTTRGPOL <CPD>               **Set** the burst **trigger slope** to <POS> or <NEG>.
- BSTCOUNT <NR1>               **Set** the burst **count** to <nr1> cycles.
- BSTPHASE <NRF>               **Set** the burst **phase** to <NRF> degree.
- BST <CPD>                       **Set** the **burst** to <OFF>, <NCYC>, <GATED> or <INFINITE>.

## 25 - Remote Commands

### External counter commands

---

#### External counter commands

- CNTRSWT <CPD>                    **Set the external counter** to <ON> or <OFF>
- CNTRCPLNG <CPD>                **Set the counter source** to <AC> or <DC> coupled input.
- CNTRTYPE <CPD>                 **Set the counter type** to <FREQUENCY>, <PERIOD>, <WIDTH>, <NWIDTH> or <DUTY>.
- CNTRVAL?                            **Return the currently measured count** value in <nrf> format. If the count type is frequency, then the returned value is in Hz, if the count type is duty cycle, then the returned value is in %, else the returned value is in seconds.

#### Clock and miscellaneous commands

- CLKSRC <CPD>                    **Set the clock source** to <INT> or <EXT>.
- CLKSRC?                            **Return the clock source** <INT> or <EXT>.
- CHNTRG <CPD>                    **Sends manual trigger** to channel <ONE> or <TWO>. This command is the same as pressing the TRIGGER key. Its effect will depend on the context in which it is asserted. If the trigger source is manual and the generator is set to perform triggered burst or triggered sweep operation, this command sends a trigger pulse to the generator. If the trigger source is manual and the generator is set to perform gated burst operation, this command simply inverts the level of the manual trigger to high or low.

#### Dual-channel function commands

- AMPLCPLNG <CPD>                **Set amplitude coupling** to <ON> or <OFF>.
- OUTPUTCPLNG <CPD>              **Set output coupling** to <ON> or <OFF>.
- FRQCPLSWT <CPD>                **Set waveform frequency coupling** to <ON> or <OFF>.
- TRACKING <CPD>                 **Set channel tracking** to <OFF>, <EQUAL> or <INVERT>.

## 25 - Remote Commands

### System and status commands

---

#### System and status commands

- **\*CLS** **Clear Status.** Clears the Status structure. This indirectly clears the Status Byte Register.
- **\*ESE** **Set the Standard Event Status Enable Register** to the value of <NRF>
- **\*ESE?** **Return** the value in the Standard **Event Status Enable Register** in <NR1> numeric format. The syntax of the response is <NR1><RMT>
- **\*ESR?** **Return** the value in the Standard **Event Status Register** in <NR1> numeric format.  
**THE REGISTER IS THEN CLEARED.**  
The response is <NR1><RMT>. See 'Status reporting' section for details.
- **\*IST?** **Return ist local message** as defined by IEEE Std. 488.2. The syntax of the response is 0<RMT>, if the local message is false, or 1<RMT>, if the local message is true.
- **\*OPC** **Set the Operation Complete bit** (bit 0) in the Standard Event Status Register. This will happen immediately the command is executed because of the sequential nature of all operations.
- **\*OPC?** **Query Operation Complete status.** The response is always 1<RMT> and will be available immediately the command is executed because all commands are sequential.
- **\*PRE** **Set the Parallel Poll Enable Register** to the value <NRF>.
- **\*PRE?** **Return** the value in the **Parallel Poll Enable Register** in <NR1> numeric format. The syntax of the response is <NR1><RMT>
- **\*SRE** **Set the Service Request Enable Register** to <NRF>.
- **\*SRE?** **Return** the value of the **Service Request Enable Register** in <NR1> numeric format. The syntax of the response is <NR1><RMT>
- **\*STB?** **Return** the value of the **Status Byte Register** in <NR1> numeric format. The syntax of the response is <NR1><RMT>
- **\*WAI** **Wait for Operation Complete true.** As all commands

## 25 - Remote Commands

### System and status commands

---

are completely executed before the next is started this command takes no additional action.

- \*TST? The PSU has no **self-test** capability and the response is always 0 <RMT>
- EER? **Query and CLEAR Execution Error Register.** The response format is <NR1><RMT>.
- QER? **Query and CLEAR Query Error Register.** The response format is <NR1><RMT>
- \*LRN? **Return the complete setup of the instrument as a binary data block.** To re-install the setup the block should be returned to the instrument exactly as it is received. The syntax of the response is LRN <BIN>. The settings in the instrument are not affected by execution of the \*LRN? Command.
- LRN **Install data from a previous \*LRN? command.**
- \*RST **Reset** the instrument parameters to their **default values.**
- \*RCL **Recall** a previously stored instrument **set-up file** from the specified non-volatile memory location.
- \*SAV **Save** the complete instrument **set-up file** to the specified non-volatile memory location.
- \*TRG This command is the same as pressing the **TRIGGER key**. Its effect will depend on the context in which it is asserted. If the trigger source is manual and the generator is set to perform triggered burst or triggered sweep operation, this command sends a trigger pulse to the generator. If the trigger source is manual and the generator is set to perform gated burst operation, this command simply inverts the level of the manual trigger to high or low.
- \*IDN? **Return the instrument identification.** The exact response is determined by the instrument configuration and is of the form of <Manufacturer, Model, Serial No., XX.xx – YY.yy’ – ZZ.zz> where ‘XX.xx’ is the revision of the main firmware and ‘YY.yy’ is the revision of the remote interface firmware and ‘ZZ.zz’ is the revision of the USB flash drive firmware
- BEEPMODE **Set beep mode** to <ON>, <OFF>, <WARN>, or <ERROR>
- BEEP **Sound one beep.**

## 25 - Remote Commands

### Interface management commands

---

#### Interface management commands

- LOCAL **Go to local.** This does not release any active interface lock so that the lock remains with the selected interface when the next remote command is received.
- ADDRESS? **Return the bus address of the instrument;** This is the address used by GPIB, if fitted, or may be used as a general identifier over the other interfaces.
- IPADDR? **Return the present IP address of the LAN interface,** provided it is connected. If it is not connected, the response will be the static IP if configured to always use that static IP, otherwise it will be 0.0.0.0 if waiting for DHCP or Auto-IP. The response is nnn.nnn.nnn.nnn<RMT>, where each nnn is 0 to 255.
- NETMASK? **Return the present netmask of the LAN interface,** provided it is connected. The response is nnn.nnn.nnn.nnn<RMT>, where each nnn is 0 to 255.
- NETCONFIG? **Return the first means by which an IP address will be sought.** The response is <CRD><RMT> where <CRD> is DHCP, AUTO or STATIC.

## 25 - Remote Commands

### Interface management commands

---

The following commands specify the parameters to be used by the LAN interface.

#### NOTE:



A power cycle is required after these commands are sent before the new settings are used (or returned in response to the queries listed above). The instrument does not attempt to check the validity of the IP address or netmask in any way other than checking that each part fits in 8 bits. The rear panel LAN RESET switch will override these commands and restore the defaults as described earlier.

---

- NETCONFIG <CPD>                      **Specify** the means by which an **IP address** will be sought. <CPD> must be one of DHCP, AUTO or STATIC.
- IPADDR <quad>                         **Set** the potential static **IP address** of the LAN interface (as on the webpage). The parameter must be strictly a dotted quad for the IP address, with each address part an <NR1> in the range 0 to 255, (e.g. 192.168.1.101).
- NETMASK <quad>                       **Set** the **netmask** to accompany the static IP address of the LAN interface. The parameter must be strictly a dotted quad for the netmask, with each part an <NR1> in the range 0 to 255, (e.g. 255.255.255.0).

#### Calibration specific commands

See 'Calibration' section for details of calibration specific commands.

#### Error messages

Each error message has a number; only this number is reported via the remote-control interfaces. Error message numbers are placed in the Execution Error Register where they can be read via the remote interfaces.



# 26. APPENDIX 1.

## Information, warning and error messages

In the following list where [VALUE] appears a numeric value will be inserted in the message which is appropriate to the parameter currently being edited. Message numbers that are omitted are reserved and not currently used. Some numbers can produce two different messages depending on the current instrument editing mode; these are indicated by 'or' in the list.

### Error messages

- 1 Firmware Update / Battery Fail. Initialised to factory default state.
- 2 Frequency / Period invalid. Frequency lower limit 1mHz. Period upper limit 1000s.
- 3 Frequency / Period invalid. Frequency upper limit [VALUE] Period lower limit [VALUE].
- 4 Pulse width invalid. Limited by pulse period.
- 5 Pulse width invalid. Lower limit [VALUE].
- 6 Pulse edge time invalid. Limited by pulse width.  
OR Pulse rise time invalid. Limited by pulse width.
- 7 Pulse edge time invalid. Lower limit [VALUE].  
OR Pulse rise time invalid. Lower limits [VALUE].
- 8 Invalid entry. Width cannot be less than  $(0.625 * Rise + 0.625 * Fall + [VALUE])$ .
- 9 Invalid entry. Period cannot be less than  $(Delay + Width + 0.625 * Rise + 0.625 * Fall + [VALUE])$ .
- 10 Pulse width deviation invalid for current pulse parameter settings.
- 11 Square width invalid. Lower limit [VALUE].
- 12 Bitrate invalid. Lower limit 1ubps.
- 13 Bitrate invalid. Upper limit [VALUE].
- 14 Frequency / Period invalid. Frequency lower limit 1uHz. Period upper limit 1 000000s.
- 15 Frequency / Period invalid for Sine. Frequency upper limit [VALUE]. Period lower limit [VALUE].  
Or Frequency / Period invalid for Square. Frequency upper limit [VALUE]. Period lower limit [VALUE].  
Or Frequency / Period invalid for Ramp. Frequency upper limit [VALUE]. Period lower limit [VALUE].  
Or Frequency / Period invalid for Arb. Frequency upper limit [VALUE]. Period lower limit [VALUE].
- 16 Ramp symmetry invalid. Upper limit 100%.
- 17 Ramp symmetry invalid. Lower limit 0%.
- 18 Square duty cycle invalid. Upper limit 99.999%.

## 26 - Appendix 1.

### Error messages

---

- 19 Square duty cycle invalid. Lower limit 0.001%.
- 20 Frequency deviation invalid for current waveform / parameter settings.
- 21 Hop frequency invalid for current waveform / parameter settings.
- 22 Sweep frequency invalid for current waveform / parameter settings.
- 23 Amplitude value invalid. Upper limit +32767.
- 24 Amplitude value invalid. Lower limit -32767.
- 25 Point number invalid. Last defined point [VALUE].
- 26 Point number invalid. First defined point 1.
- 27 Number of points invalid. Upper limit 8192.
- 28 Number of points invalid. Lower limit 1.
- 29 Please specify a filename in Short File Name (SFN) format.
- 30 AM frequency invalid. Upper limit 10MHz.
- 31 AM frequency invalid. Lower limit 1uHz.
- 32 Amplitude depth invalid. Upper limit 100%.
- 33 Amplitude depth invalid. Lower limit 0%.
- 34 FM frequency invalid. Upper limit 10MHz.
- 35 FM frequency invalid. Lower limit 1uHz.
- 36 Frequency deviation invalid. Current upper limit [VALUE]  
OR Frequency deviation invalid. Cannot exceed carrier frequency.  
Frequency plus deviation limited to [VALUE].
- 37 Frequency deviation invalid. Lower limit 0Hz.
- 38 PM frequency invalid. Upper limit 10MHz.
- 39 PM frequency invalid. Lower limit 1uHz.
- 40 Phase deviation invalid. Upper limit +360 degrees.
- 41 Phase deviation invalid. Lower limit -360 degrees.
- 42 FSK rate invalid. Upper limit 10MHz.
- 43 FSK rate invalid. Lower limit 2mHz.
- 44 Hop frequency invalid. Current upper limit [VALUE].
- 45 Hop frequency invalid. Lower limit 1uHz.
- 46 BPSK rate invalid. Upper limit 10MHz.
- 47 BPSK rate invalid. Lower limit 2mHz.
- 48 Hop phase invalid. Upper limit +360 degrees.
- 49 Hop phase invalid. Lower limit -360 degrees.
- 50 SUM frequency invalid. Upper limit 10MHz.
- 51 SUM frequency invalid. Lower limit 1uHz.
- 52 SUM modulation level invalid. Upper limit 100%.

## 26 - Appendix 1.

### Error messages

---

- 53 SUM modulation level invalid. Lower limit 0%.
- 54 PWM frequency invalid. Upper limit 10MHz.
- 55 PWM frequency invalid. Lower limit 1uHz.
- 56 PWM deviation invalid. Maximum deviation limited by carrier width setting.
- 57 PWM deviation invalid. Lower limit 0ns.
- 58 Arb DC cannot be selected when modulation is enabled and vice versa.
- 59 FM invalid for Noise / PRBS.
- 60 PM invalid for Noise / PRBS.
- 61 FSK invalid for Noise / PRBS.
- 62 BPSK invalid for Noise / PRBS.
- 63 PWM invalid for Noise / PRBS.
- 64 PWM is only valid for Pulse.
- 65 Start frequency invalid. Lower limit 1uHz.
- 66 Start frequency invalid. Cannot be greater than stop frequency.
- 67 Stop frequency invalid. Cannot be less than start frequency.
- 68 Stop frequency invalid. Current upper limit [VALUE].
- 69 Sweep time invalid. Lower limit 1us.
- 70 Sweep time invalid. Upper limit 500s.
- 71 Trigger period invalid. Lower limit [VALUE].
- 72 Trigger period invalid. Upper limit 500s.
- 73 Arb DC cannot be selected when frequency sweep is enabled and vice versa.
- 74 Sweep invalid for Noise.
- 75 Burst count invalid. Upper limit 2147483647.
- 76 Burst count invalid. Lower limit 1.
- 77 Trigger period invalid. Upper limit 500s.
- 78 Trigger period invalid. Lower limit [VALUE].
- 79 Arb DC cannot be selected when burst is enabled and vice versa.
- 80 OUTPUT VOLTAGE OVERLOAD. Output turned off for safety.
- 81 Invalid entry. High level upper limit [VALUE].
- 82 Invalid entry. Low level lower limit [VALUE].
- 83 Invalid entry. Amplitude upper limit [VALUE].
- 84 Invalid entry. Amplitude lower limit [VALUE].
- 85 Invalid entry. Offset upper limit [VALUE].
- 86 Invalid entry. Offset lower limit [VALUE].
- 87 Phase invalid. Upper limit +360 degrees.
- 88 Phase invalid. Lower limit -360 degrees.

## 26 - Appendix 1.

### Error messages

---

- 89 Output load invalid. Upper limit 10000 ohms.
- 90 Output load invalid. Lower limit 1 ohms.
- 91 Frequency coupling cannot be turned on when modulation is enabled.
- 92 Frequency coupling cannot be turned on when frequency sweep is enabled.
- 93 Frequency coupling cannot be turned on. Pulse waveform can only be coupled with Pulse waveform.
- 94 Frequency coupling cannot be turned on when Noise is set as main output.
- 95 Frequency coupling cannot be turned on when DC is set as main output.
- 96 Outputs cannot be coupled when Tracking is selected.
- 97 Amplitudes cannot be coupled when Tracking is selected.
- 98 Frequencies cannot be coupled when Tracking is selected.
- 99 Tracking cannot be selected when outputs are coupled.
- 100 Tracking cannot be selected when amplitudes are coupled.
- 101 Tracking cannot be selected when frequencies are coupled.
- 102 Channel 2 parameters not available when Tracking is selected.
- 103 Invalid entry. Upper limit 99%.
- 104 Invalid entry. Lower limit 1%.
- 105 GPIB address invalid. Upper limit 30.
- 106 GPIB address invalid. Lower limit 0.
- 107 Incorrect password. Please try again.
- 108 Password did not match. Please try again.
- 109 Unsupported USB device. Device current limited to 500mA.
- 110 Unsupported USB device. Please insert USB-Flash disk only.
- 111 Unsupported remote command.
- 112 Unsupported remote command parameter.
- 113 USB HOST hardware not found.
- 114 Please insert USB-Flash disk and try again.
- 115 USB-Flash disk files limited to 1260.
- 116 Please edit different file name as the current file already exist.
- 117 FATAL ERROR: Invalid waveform location.
- 118 FATAL ERROR: Invalid setup location.
- 119 Unsupported waveform file or the file may be corrupted, please wait.
- 120 Unsupported setup file or the file may be corrupted, please wait.
- 121 Unsupported command on the Webpage.
- 122 Unable to Recall instrument setup. The specified location is empty.

## 26 - Appendix 1.

### Error messages

---

- 123 Test FAILED at address [VALUE]. Data written [VALUE]. Data read back [VALUE].
- 124 PM invalid for Pulse.
- 125 BPSK invalid for Pulse.
- 126 FM invalid for Pulse.
- 127 FSK invalid for Pulse.
- 128 Sweep invalid for Pulse.
- 129 Finite Burst invalid for frequencies above [VALUE].
- 130 Channel 2 parameters not available when channel 2 is set to output channel 1 sync waveform.
- 131 Gated Burst invalid for frequencies above [VALUE].
- 132 Frequency coupling cannot be turned on when burst is enabled.
- 133 Frequency and amplitude coupling cannot be turned on when channel 2 is set to output channel 1 sync.
- 134 Tracking cannot be turned on when channel 2 is set to output channel 1 sync waveform.
- 135 Channel 2 cannot be set to output channel 1 sync when frequencies or amplitudes are coupled.
- 136 Channel 2 cannot be set to output channel 1 sync when channels are in tracking mode.
- 137 Channel 2 parameters not available when Tracking is selected.
- 138 Invalid entry. Order upper limit 50.
- 139 Invalid entry. Order lower limit 1.
- 140 Invalid entry. Amplitude. percent upper limit 100.0%.
- 141 Invalid entry. Amplitude. percent lower limit 0.0%.
- 142 Invalid entry. Phase upper limit 360.0 degrees.
- 143 Invalid entry. Phase lower limit -360.0 degrees.
- 144 Amplitude coupling cannot be turned on when ASK modulation is enabled.
- 145 Amplitude coupling cannot be turned on when DC is set as main output.
- 146 Amplitude invalid. Carrier amplitude cannot be less than hop amplitude.
- 147 Hop amplitude invalid. Cannot be less than 0 Vpp..
- 148 ASK rate invalid. Upper limit 10MHz.
- 149 ASK rate invalid. Lower limit 2mHz.
- 150 Amplitude modulation invalid for carrier frequencies above [VALUE].
- 151 Amplitude shift keying invalid for carrier frequencies above [VALUE].
- 152 SUM modulation invalid for carrier frequencies above [VALUE].
- 153 Feature not available in this model.
- 154 Pulse delay invalid. Limited by pulse period.

## 26 - Appendix 1.

### Error messages

---

- 155 Pulse delay time invalid. Lower limit 0ns.
- 156 Pulse fall time invalid. Limited by pulse width.
- 157 Pulse fall time invalid. Lower limit [VALUE].
- 158 External clock invalid. Switching back to internal reference clock. Please wait.

#### Warning messages

- 1 DC Offset set to default 0V.
- 2 Frequency coupling turned off.
- 3 Wrong key pressed. Press keys as instructed.
- 4 Instrument is not calibrated.
- 5 Calibration values cleared. Please power-cycle the instrument.
- 6 USB-Flash disk waveform files limited to 1260.
- 7 USB-Flash disk setup files limited to 1260.
- 8 Please press again to overwrite.
- 9 File was created from 1-CHN-Model. Please press again to copy.
- 10 File was created from LF-Model. Please press again to copy.
- 11 File was created from different firmware. Please press again to copy.
- 12 Amplitude coupling turned off.
- 13 Hop amplitude set to maximum allowed for current carrier amplitude and offset settings.
- 14 Burst mode turned off to output DC.
- 15 Frequency changed to maximum allowed for Ramp waveform.
- 16 Frequency changed to maximum allowed for Arb waveform for current settings.
- 17 Frequency changed to maximum allowed for Square waveform.
- 18 Frequency changed to maximum allowed for Sine waveform for current settings.
- 20 Square symmetry set to default 50%.
- 21 Pulse parameters changed to maximum allowed for current settings.

## 26 - Appendix 1.

### Information messages

---

#### Information messages

- 501 Key test successful.
- 502 New password stored.
- 503 Select a unit to enter value or press Cancel.
- 504 Please reduce the files on USB-Flash disk and try again.
- 505 Test data has been written to RAM.
- 506 RAM test successful.
- 507 Press Trigger key to send a manual trigger pulse.
- 508 Press Trigger key to invert the manual trigger level. Current level high or Press Trigger key to invert the manual trigger level. Current level low.
- 509 To send a manual trigger pulse press Trigger key again.
- 510 To invert manual trigger level, press Trigger key again.
- 511 Manual trigger pulse sent.
- 512 Manual trigger level inverted. Current level high or Manual trigger level inverted. Current level low.



## 26 - Appendix 1.

### Other information messages

---

#### Other information messages

Please wait.

Please wait. The file is being read from USB-Flash disk.

Please wait. The file is being written to USB-Flash disk.

Please wait. The current settings are being saved.

Please wait. The local setup file is being recalled.

Please wait. The local setup file is being deleted.

Please wait. The local waveform file is being deleted.

Please wait. Writing test data to RAM.

Please wait. Reading test data from RAM.

Are you sure you want to delete? Press Yes to confirm. Press No to cancel.

## 27 - Appendix 2.

Factory default settings

# 27. APPENDIX 2.

## Factory default settings

Output Configuration	Factory Setting
Function	Sine wave
Frequency	10 kHz
Amplitude / Offset	1 Vpp / 0.000 Vdc
Output Termination	50 $\Omega$
Auto range	On
Output Polarity	Normal
Output Phase	0 degrees
Square Duty Cycle	50 %
Ramp Symmetry	50 %
Pulse Width (Duty Cycle)	50 $\mu$ s (50 %)
Pulse Edge	10 ns
Noise Source	Gaussian White Noise
PRBS Bit Rate	10 kbps
PRBS Type	PRBS – LFSR Length 7
Arb Waveform	Exponential Rise
Arb Filter	Step Filter
Output State	Off
Sync Out State	Off; Channel 2 is configured as a separate independent channel with same default configurations as channel 1
Modulation	Factory Setting
Carrier AM, FM, PM, ASK, FSK, BPSK, SUM	10 kHz Sine wave
Carrier PWM	10 kHz Pulse
Modulation Waveform AM, FM, PM, SUM, PWM	1 kHz Sine wave
Modulation Source AM, FM, PM, ASK, FSK, BPSK, SUM, PWM	Internal
AM Depth	50 %
FM Deviation	2 kHz
PM Deviation	180 degrees
FSK Hop Frequency	5 kHz
FSK Rate	1 kHz

## 27 - Appendix 2.

### Factory default settings

---

FSK Polarity	Positive
SUM Modulation Level	50 %
BPSK Hop Phase	180 degrees
BPSK Rate	1 kHz
BPSK Polarity	Positive
ASK Hop Amplitude	500 mVpp
ASK Rate	1 kHz
ASK Polarity	Positive
PWM Width Deviation	50 %
Modulation State	Off
<b>Sweep</b>	<b>Factory Setting</b>
Start / Stop Frequency	1 kHz / 10 kHz
Sweep Time	500 us
Sweep Type / Mode	Linear Up / Continuous
Sweep Trigger Source	Internal
Sweep Trigger Polarity	Positive (Rising Edge)
Sweep Trigger Period	5 ms
Sweep State	Off
<b>Burst</b>	<b>Factory Setting</b>
Burst Type	Triggered, N-Cycle
Burst Count	1 Cycle
Burst Trigger Source	Internal
Burst Trigger Polarity	Positive (Rising Edge / High Level)
Burst Trigger Period	5 ms
Burst Start Phase	0 degrees
Burst State	Off
<b>System-Related Operations</b>	<b>Factory Setting</b>
Power-Down Recall	Disabled
Display Mode	On
Error Queue	Errors are Cleared
Stored States, Stored Arbs	No Change
Output State	Off
<b>Remote Interface Configuration</b>	<b>Factory Setting</b>
GPIO Address	5
DHCP	On
Auto IP	On
IP Address	192.168.1.100

## 27 - Appendix 2.

### Factory default settings

---

Subnet Mask	255.255.0.0
Default Gateway	0.0.0.0
DNS Server	0.0.0.0
Host Name	<i>none</i>
Domain Name	<i>none</i>
<b>Calibration</b>	<b>Factory Setting</b>
Calibration State	Not protected

# 28. APPENDIX 3.

## Waveform manager plus V4.13

### Arbitrary waveform creation and management software

The Waveform Manager program allows construction, editing, exchange, translation and storage of many types of waveform data. It is compatible with all Aim-TTi waveform generation products.

Waveforms may be generated by equation entry, freehand drawing, combining existing waveforms or any combinations of these methods.

Data upload and download are possible via LAN, USB or GPIB subject to a compatible GPIB adapter being correctly installed and configured in your PC.

Files can also be uploaded/downloaded to the USB flash drive and the flash drive then used directly with the instrument.

Both upload and download of waveform data are possible.

Text data may be read from the Windows clipboard and used to create a waveform. The text data format is very free and will allow most lists of numbers, with or without intervening text, to be read as waveform data points. Waveform data may also be pasted to the clipboard for insertion into other programs.

Waveform data may also be read from files conforming to the CSV file format.

Waveforms are displayed in fully scalable windows and may be manipulated graphically. Any number of waveforms in any of the supported types may be displayed simultaneously.

On-line help is available in the following three ways:

- The help menu contains a contents option from which you can go to any section of the on-line help file or browse particular areas or the whole file. It is also possible to use the Index and Find operations of the Windows help system to search for items which are not listed directly in the contents section.
- Some dialog boxes have a Help button which, when clicked, will open the on-line help file at the section containing the description of that dialog box.
- From most windows/dialogues the F1 key will open the help file at the relevant section.

Waveform Manager Plus allows you to keep waveforms for different projects separate from each other on your hard drive. A project may be placed anywhere, in any directory folder and all waveform files for that project will be stored in a structure below that directory. A project is identified by a user defined name. Each project maintains its own library of expressions.

## 29. SPECIFICATION

MODEL:	TGF4042	TGF4082	TGF4162	TGF4242
<b>Waveforms</b>				
Standard waveforms:	Sine, Square, Ramp (Variable Symmetry), Triangle (50% Ramp symmetry), Positive Ramp (100% Ramp symmetry), Negative Ramp (0% Ramp symmetry), Pulse, Noise (Gaussian), DC, Sin(x)/x, Exponential Rise, Exponential Fall, Logarithmic Rise, Logarithmic Fall, Haversine, Cardiac, Gaussian, Lorentz, D-Lorentz and 4 User Defined Arbitrary Waveforms. Dozens of useful pre-built arbitrary waveforms are also supplied on the website: <a href="http://www.aimtti.com">www.aimtti.com</a>			
			PRBS	
<b>Sine</b>				
Frequency range:	1μHz to 40MHz	1μHz to 80MHz	1μHz to 160MHz	1μHz to 240MHz
Frequency resolution:	1μHz, 14 digits		1μHz, 15 digits	
Output level (into 50Ω):	10mVp-p to 10Vp			
	≤50MHz		10mVp-p to 10Vp-p	
	≤80MHz		10mVp-p to 5Vp-p	10mVp-p to 10Vp-p
	≤120MHz		10mVp-p to 5Vp-p	10mVp-p to 5Vp-p
	≤240MHz		10mVp-p to 2.5Vp-p	10mVp-p to 2.5Vp-p
Amplitude flatness (1Vp-p relative to 10 kHz):	≤10MHz	±0.1dB		
	≤100MHz	±0.2dB		
	≤160MHz	±0.6dB		
	≤240MHz	±1.0dB		
Harmonic distortion (1Vp-p)	≤10MHz	-65dBc		
	≤50MHz	-50dBc		
	≤80MHz	-40dBc		
	≤130MHz	-35dBc		
	≤240MHz	-28dBc		
Total harmonic distortion DC to 20kHz (typical):	0.05%			
Non-harmonic spuri:	-65dBc			
Phase noise (10MHz, 1Vp-p, 10kHz offset):	-113dBc/Hz			
<b>Square</b>				
Frequency range:	1μHz to 25MHz	1μHz to 100MHz		
Frequency resolution:	1μHz, 14 digits	1μHz, 15 digits		
Output level (into 50Ω):	≤50MHz	10mVp-p to 10Vp-p		10mVp-p to 10Vp-p
	≤100MHz			10mVp-p to 4Vp-p
Duty cycle:	0.001% to 99.999%, 0.001% resolution			
Rise and fall times (typical):	≤ 4p-p	10ns, fixed		3ns, fixed
	≥ 4p-p			5ns, fixed
Aberrations (typical):	±5% of amplitude			
Jitter (RMS):	<30ps (cycle to cycle)			
<b>Ramp</b>				
Frequency range:	1μHz to 5MHz			
Frequency resolution:	1μHz, 13 digits			
Output level (into 50Ω):	10mVp-p to 10Vp-p			
Linearity error:	<0.1% to 100kHz		<0.1% to 200kHz	
Variable symmetry:	0.00% to 100.00%, 0.01% resolution			
<b>Pulse</b>				
Frequency range:	1mHz to 25MHz		1mHz to 100MHz	
Frequency Resolution:	1mHz, 11 digits		1mHz, 12 digits	
Output level (into 50Ω):	≤ 50MHz	10mVp-p to 10Vp-p		10mVp-p to 10Vp-p
	≤ 100MHz			10mVp-p to 4Vp-p
Aberrations (Typical):	±5% of amplitude (for transition time 10ns)		±5% of amplitude (for transition time 5ns)	
	±3% of amplitude (for transition time 20ns)		±3% of amplitude (for transition time 10ns)	
	<±2% of amplitude (for transition time > 40ns)		<±2% of amplitude (for transition time > 20ns)	

## 29 - Specification

MODEL:		TGF4042	TGF4082	TGF4162	TGF4242
Jitter RMS:		<30ps (cycle to cycle)			
Rise and Fall Times:	Range: $\leq 4Vp-p$	8ns to 799.99999984s (10% to 90%)		3ns to 799.99999989s (10% to 90%)	
	Range: $> 4Vp-p$			5ns to 799.99999989s (10% to 90%)	
	Resolution:	100ps			
	Accuracy:	$\pm 500ps \pm 0.01\%$ of period			
	Rise and Fall times can be independently varied or can be varied together simultaneously.				
Width:	Range: $\leq 4Vp-p$	20ns to 999.99999980s		5ns to 999.99999995s	
	Range: $> 4Vp-p$			10ns to 999.99999990s	
	Resolution:	100ps			
	Accuracy:	$\pm 200ps \pm 0.01\%$ of period			
Duty:		0.001% to 99.999%, 0.01% resolution			
Delay:	Range:	0ns to 999.9999996s		0ns to 999.9999998s	
	Resolution:	100ps			
	Accuracy:	$\pm 200ps \pm 0.01\%$ of period			
	Delay can be entered as absolute delay or phase.				
<b>Arbitrary</b>					
In built arbitrary waveforms (Sin(x)/x, Exponential Rise, Exponential Fall, Logarithmic Rise, Logarithmic Fall, Haversine, Cardiac, Gaussian, Lorentz and D-Lorentz). Up to 4 user-defined waveforms may be stored in non-volatile memory. Waveforms can be defined by downloading of waveform data via remote interfaces or from the instrument's front panel.					
Waveform Memory Size:		8192 points			
Vertical Resolution:		14 bits		16 bits	
Frequency Range:	In built	1 $\mu$ Hz to 2MHz		1 $\mu$ Hz to 4MHz	
	User defined	1 $\mu$ Hz to 40MHz		1 $\mu$ Hz to 80MHz	
Frequency Resolution:	In built	1 $\mu$ Hz, 13 digits			
	User defined	1 $\mu$ Hz, 14 digits			
Output Level (into 50 $\Omega$ ):		10mVp-p to 10Vp-p			
Sampling rate:		400MSa/s		800MSa/s	
Point to Point Jitter (Typical):		2.5ns		1.25ns	
Rise and Fall Times:		<8ns		<5ns for 100MHz filter <8ns for 62.5MHz filter	
Effective Analogue Bandwidth (-3dB):		50MHz		62.5MHz, 100MHz, User Selectable	
<b>Noise</b>					
Gaussian White Noise: Noise can also be used as modulating waveform.					
Bandwidth (-3dB):		50MHz		100MHz	
Noise crest factor ( $Vp/V_{rms}$ ):		6.4		5.16	
Output Level (into 50 $\Omega$ ):		10mVp-p to 10Vpp			
<b>PRBS (TGF4162 &amp; TGF4242 only)</b>					
Bit Rate		-		1 $\mu$ bps to 100Mbps, 1 $\mu$ bps resolution	
Sequence Length:		-		2m - 1, where m = 7, 9, 11, 15, 20, 23, 29 or 31	
Rise and Fall Times (Typical):	$\leq 4Vp-p$	-		3ns, Fixed	
	$> 4Vp-p$	-		5ns, Fixed	
Output Level:		-		10mVp-p to 10Vpp into 50 $\Omega$	
<b>Harmonic Output (TGF4162 &amp; TGF4242 only)</b>					
Harmonic waveforms can be defined and stored in user-defined arbitrary waveform locations.					
Frequency Range:		-		1 $\mu$ Hz to 80MHz	
Frequency Resolution:		-		1 $\mu$ Hz, 14 digits	
Harmonic Order:		-		1 to 50, Up to 16 different harmonics order can be defined	
Harmonic Amplitude:		-		0.0% to 100.0% of output amplitude, 0.1% resolution	
Harmonic Phase:		-		-360.0 to +360.0 degrees, 0.1 degree resolution	
Output level (into 50 $\Omega$ ):		-		10mVp-p to 10Vp-p	

### Internal frequency reference

Internal Modulating Frequency:	< $\pm 1$ ppm
Amplitude Depth:	< $\pm 1$ ppm first year
Internal Modulating Frequency:	<1ppm over the specified temperature range

MODEL:	TGF4042	TGF4082	TGF4162	TGF4242
<b>Modulation</b>				
<b>AM (Amplitude Modulation) Normal &amp; Suppressed Carrier</b>				
Carrier Waveforms:	Sine, Square, Ramp, Pulse, Noise, Arb			
	-	PRBS		
Maximum Carrier Frequency:	25MHz, subject to carrier waveform		50MHz, subject to carrier waveform.	
Modulation Source:	Internal/External			
Internal Modulating Waveforms:	Sine, Square, Positive Ramp, Negative Ramp, Triangle, Gaussian Noise, DC, Sinc, Exponential Rise, Exponential Fall, Logarithmic Rise, Logarithmic Fall, Haversine, Gaussian, Lorentz, D-Lorentz, Cardiac and User Defined Arbs			
	-	PRBS-PN7, PN9, PN11, PN15, PN20, PN23, PN29, PN31		
Internal Modulating Frequency:	1μHz to 10MHz, 1μHz resolution			
Amplitude Depth:	0.00% to 100.00%, 0.01% resolution			
<b>FM (frequency modulation)</b>				
Carrier Waveforms:	Sine, Square, Ramp, Arb			
Modulation Source:	Internal/External			
Internal Modulating Waveforms:	Sine, Square, Positive Ramp, Negative Ramp, Triangle, Gaussian Noise, DC, Sinc, Exponential Rise, Exponential Fall, Logarithmic Rise, Logarithmic Fall, Haversine, Gaussian, Lorentz, D-Lorentz, Cardiac and User Defined Arbs.			
	-	PRBS-PN7, PN9, PN11, PN15, PN20, PN23, PN29, PN31		
Internal Modulating Frequency:	1μHz to 10MHz, 1μHz resolution			
Frequency Deviation:	DC to Fmax/2, 1μHz resolution			
<b>PM (phase modulation)</b>				
Carrier Waveforms:	Sine, Square, Ramp, Arb			
Modulation Source:	Internal/External			
Internal Modulating Waveforms:	Sine, Square, Positive Ramp, Negative Ramp, Triangle, Gaussian Noise, DC, Sinc, Exponential Rise, Exponential Fall, Logarithmic Rise, Logarithmic Fall, Haversine, Gaussian, Lorentz, D-Lorentz, Cardiac and User Defined Arbs.			
	-	PRBS-PN7, PN9, PN11, PN15, PN20, PN23, PN29, PN31		
Internal Modulating Frequency:	1μHz to 10MHz, 1μHz resolution			
Phase Deviation:	-360.000 to +360.000 degrees, 0.001 degree resolution			
<b>ASK (Amplitude Shift Keying)</b>				
Carrier Waveforms:	Sine, Square, Ramp, Pulse, Noise, Arb			
	-	PRBS		
Maximum Carrier Frequency:	25MHz, subject to carrier waveform.		50MHz, subject to carrier waveform.	
Source:	Internal/External (via TRIG IN)			
Internal Modulation:	2mHz to 10MHz (50% duty cycle square)			
<b>FSK (Frequency Shift Keying)</b>				
Carrier Waveforms:	Sine, Square, Ramp, Arb			
Source:	Internal/External (via TRIG IN)			
Internal Modulation:	2mHz to 10MHz (50% duty cycle square)			
<b>BPSK (Binary Phase Shift Keying)</b>				
Carrier Waveforms:	Sine, Square, Ramp, Arb			
Modulation Source:	Internal/External (via TRIG IN)			
Internal Modulation:	2mHz to 10MHz (50% duty cycle square)			
<b>PWM (Pulse Width Modulation)</b>				
Carrier Waveforms:	Pulse			
Modulation Source:	Internal/External			
Internal Modulating Waveforms:	Sine, Square, Positive Ramp, Negative Ramp, Triangle, Gaussian Noise, DC, Sinc, Exponential Rise, Exponential Fall, Logarithmic Rise, Logarithmic Fall, Haversine, Gaussian, Lorentz, D-Lorentz, Cardiac, and User Defined Arbs			
	-	PRBS-PN7, PN9, PN11, PN15, PN20, PN23, PN29, PN31		
Internal Modulating Frequency:	1μHz to 10MHz, 1μHz resolution			
Pulse Width Deviation:	0% to 100% of pulse width, 0.01% resolution			



## 29 - Specification

MODEL:	TGF4042	TGF4082	TGF4162	TGF4242
<b>SUM (Additive Modulation) (TGF4162 &amp; TGF4242 only)</b>				
Carrier Waveforms:	-		Sine, Square, Ramp, Pulse, Noise, PRBS, Arb	
Maximum Carrier Frequency:	-		50MHz, subject to carrier waveform.	
Modulation Source:	-		Internal/External	
Internal Modulating Waveforms:	-		Sine, Square, Positive Ramp, Negative Ramp, Triangle, Gaussian Noise, DC, Sinc, Exponential Rise, Exponential Fall, Logarithmic Rise, Logarithmic Fall, Haversine, Gaussian, Lorentz, D-Lorentz, Cardiac, PRBS-PN7, PN9, PN11, PN15, PN20, PN23, PN29, PN31 and User Defined Arbs.	
Internal Modulating Frequency:	-		1µHz to 10MHz, 1µHz resolution	
Ratio:	-		0% to 100%, 0.01% resolution	

### Triggered Burst

Each active edge of the trigger signal will produce one burst of the waveform.

Carrier Waveforms:		Sine, Square, Ramp, Pulse, Arb: A fixed number of cycles, specified as number of cycles are generated at every trigger event. Noise: Noise is reset to its start condition at every trigger event. Allows generating same random noise sequence.		
	-		PRBS: A fixed number of bits, specified as number of cycles are generated at every trigger event	
Maximum Carrier Frequency:		25MHz (finite cycles), Fmax(infinite), subject to carrier waveform.	50MHz (finite cycles), Fmax(infinite), subject to carrier waveform.	
Number of Cycles:		1 to 2147483647 and infinite.		
Trigger Repetition Rate:	Internal	2mHz to 25MHz		2mHz to 50MHz
	External	DC to 1MHz		
Trigger Signal Source:	Internal	from keyboard or trigger generator.		
	External	from TRIG IN or remote interface.		
Trigger Start/Stop Phase:		-360.000 to +360.000 degrees, 0.001 degree resolution. Phase off-set cannot be set for Noise and PRBS waveforms.		

### Gated

Waveform will run while the Gate signal is true and stop while false.

Carrier Waveforms:		Sine, Square, Ramp, Pulse, Noise, Arb		
	-		PRBS	
Maximum Carrier Frequency:		25MHz, subject to carrier waveform.	50MHz, subject to carrier waveform.	
Trigger Repetition Rate:	Internal	2mHz to 25MHz		2mHz to 50MHz
	External	DC to 1MHz		
Gate Signal Source:	Internal	from keyboard or trigger generator.		
	External	from TRIG IN or remote interface.		
Gate Start/Stop Phase:		-360.000 to +360.000 degrees, 0.001 degree resolution. Phase offset cannot be set for Noise and PRBS waveforms		

### Sweep

Frequency sweep capability is provided for both standard and arbitrary waveforms

Carrier Waveforms:	Sine, Square, Ramp, Arb			
Sweep Mode:	Linear or logarithmic, triggered or continuous.			
Sweep Direction:	Up or Down			
Sweep Range:	From 1µHz to Fmax. Phase continuous. Independent setting of the start and stop frequency.			
Sweep Time:	1µs to 500s (9 digit resolution).			
Sweep Trigger Source:	The sweep may be free run or triggered from the following sources: Internal from keyboard or trigger generator. Externally from TRIG IN input or remote interface. External trigger repetition rate: DC to 1MHz			

MODEL:	TGF4042	TGF4082	TGF4162	TGF4242
<b>Trigger Generator</b>				
Internal Source Rate or Frequency:	20ns to 500s or 2mHz to 50MHz square waves adjustable in 10ns steps.		40ns to 500s or 2mHz to 25MHz square waves adjustable in 10ns steps.	
Resolution:	10ns, 11 digits			
Each channel has its own trigger generator. Channel 1 trigger is available for external use from the MAIN OUT 2 socket when Channel 2 is configured to output Channel 1 sync waveform and sync source is set to trigger.				

<b>Dual-channel operations</b>	
<b>Tracking</b>	
Independent (Off):	The channels are independent of each other.
Equal:	The two channels are identical and behave identically.
<b>Coupling</b>	
Frequency coupling:	The frequencies of the two channels can be coupled. Changing the frequency of one channel changes the frequencies of both channels.
Amplitude (and DC Offset) coupling:	Amplitude (and DC offset) of the two channels can be coupled. Changing the amplitude and offset on one channel changes the amplitude and offset of both channels.
Output coupling:	Output On/Off can be coupled. Switching the output On/Off on one channel switches the output On/Off of both channels.
<b>Characteristics</b>	
Relative phase:	-360.000 to 360.000 degrees, 0.001 degree resolution (Phase offset cannot be set for Noise)
Channel to channel Skew (typical):	<1ns (when performing identical operations)
Crosstalk (typical):	<-80db

<b>External Frequency Measurement</b>		
Function:	Frequency, Period, Positive Width, Negative Width, Duty Cycle	
Frequency Range:	AC coupled	3Hz to >125MHz
	DC coupled	100mHz to >125MHz
Source:	AC coupled	REF / COUNT (AC) IN
	DC coupled	TRIG / COUNT (DC) IN
Frequency Resolution:	Up to 7 digits displayed.	
Measurement Time:	Automatic	
Input Range and Sensitivity:	AC coupled	≤50MHz 100mVpp - 5Vpp >50MHz 250mVpp - 5Vpp Maximum input ±10V
	DC coupled	Threshold typically 1.2V; Sensitivity 100mVpp (≤50MHz), 250mVpp (<50MHz) maximum input +5V, -1V
Hysteresis:	Input hysteresis voltage	10mV
Accuracy:	±1 digit ± time base accuracy.	
Time base Accuracy:	<± 1ppm initial settling error, <± 1ppm oscillator ageing rate in the first year, <1ppm over the specified temperature range	

## 29 - Specification

MODEL:		TGF4042	TGF4082	TGF4162	TGF4242
<b>Outputs</b>					
<b>Main Outputs</b>					
Output Impedance:		50Ω			
Amplitude (Sine):		20mVp-p to 20Vp-p open circuit, 10mVp-p to 10Vp-p into 50Ω			
	≤ 50MHz		20mVp-p to 20Vp-p open circuit, 10mVp-p to 10Vp-p into 50Ω		
	≤ 80MHz		20mVp-p to 10Vp-p open circuit, 10mVp-p to 5Vp-p into 50Ω	20mVp-p to 20Vp-p open circuit, 10mVp-p to 10Vp-p into 50Ω	
	≤ 120MHz			20mVp-p to 10Vp-p open circuit, 10mVp-p to 5Vp-p into 50Ω	
	≤ 240MHz				20mVp-p to 5Vp-p open circuit, 10mVp-p to 2.5Vp-p into 50Ω
Amplitude (Pulse):		20mVp-p to 20Vp-p open circuit, 10mVp-p to 10Vp-p into 50Ω			
	≤ 50MHz			20mVp-p to 20Vp-p open circuit, 10mVp-p to 10Vp-p into 50Ω	
	≤ 100MHz			20mVp-p to 8Vp-p open circuit, 10mVp-p to 4Vp-p into 50Ω	
Amplitude can be specified open circuit (hi Z) or into an assumed load of 1Ω to 10kΩ in Vpp					
Amplitude Accuracy:		1.5% ±5mV at 1kHz into 50Ω			
DC Offset Range:		±10V. DC offset plus signal peak limited to ±10V from 50Ω.			
DC Offset Accuracy:		Typically 1% ±50mV.			
Resolution:		3 digits or 1mV for both Amplitude and DC Offset.			
<b>Sync Output</b>					
Channel 2 can be configured to output Channel 1 sync from its MAIN OUT 2 socket. Sync is a multi-function output which is automatically selected to be any of the following. Alternatively, the user can choose Sync to always be carrier referenced, to output the currently used trigger signal or turn it off.					
Carrier Waveform Sync:	Sine / Square / Ramp / Pulse / Arbs	≤ 28.125MHz A square wave with 50% duty cycle at the waveform frequency.	≤ 62.5MHz A square wave with 50% duty cycle at the waveform frequency.		
		≤ 80MHz A sine wave at the waveform frequency.	≤ 240MHz A sine wave at the waveform frequency.		
	Pattern	A positive pulse which is 1 bit rate wide at the beginning of the sequence			
Noise	No sync associated with noise.				
Modulation Sync:	AM/FM/PM/SUM/PWM	A square wave with 50% duty cycle referenced to the internal modulation waveform when modulation source is internal, or a square wave referenced to the carrier waveform when modulation source is external. No sync is associated with Noise and DC waveforms as the modulation source.			
	ASK	A square wave referenced to the trigger rate. The sync is a TTL high when hop amplitude is the output amplitude and TTL low when carrier amplitude is the output amplitude for positive slope and vice versa for negative slope.			
	FSK	A square wave referenced to the trigger rate. The sync is a TTL high when hop frequency is the output frequency and TTL low when carrier frequency is the output frequency for positive slope and vice versa for negative slope.			
	BPSK	A square wave referenced to the trigger rate. The sync is a TTL high when the hop phase is the output phase and TTL low when carrier phase is the output phase for positive slope and vice versa for negative slope.			
Sweep Sync:		A square wave that is a TTL high from the beginning of the sweep and a TTL low from the midpoint of the sweep			
Burst Sync:	Internal Trigger	A square wave with 50% duty cycle at the trigger frequency.			
	External Trigger	A square wave with same duty cycle and frequency as the external source.			
	Manual Trigger	A positive pulse which is approximately 18μs wide at the beginning of the event.			
Trigger:		Selects the current trigger signal			
Output Signal Level:		Logic level nominally 3V			
Output Impedance:		50Ω			

## 29 - Specification

MODEL:	TGF4042	TGF4082	TGF4162	TGF4242
<b>Ref Clock Output</b>				
Buffered version of the 10MHz clock currently in use (internal or external)				
Output Level:	Nominally 3V logic level from 50Ω.			

Inputs					
<b>Trigger / Count (DC) Input</b>					
For ASK, FSK, BPSK, triggered sweep, gated burst, triggered burst and DC coupled external frequency measurement.					
Frequency Range:	<table border="1"> <tr> <td>Trigger Input</td> <td>DC – 1MHz</td> </tr> <tr> <td>Counter Input</td> <td>100mHz to &gt;125MHz</td> </tr> </table>	Trigger Input	DC – 1MHz	Counter Input	100mHz to >125MHz
Trigger Input	DC – 1MHz				
Counter Input	100mHz to >125MHz				
Signal Range:	Threshold typically 1.2V; Sensitivity 100mVpp (≤50MHz), 250mVpp (>50MHz) Maximum input +5V / -1V.				
Minimum Pulse Width (Trigger Input):	50ns				
Polarity (Trigger Input):	Selectable as high/rising edge or low/falling edge.				
Input Impedance:	10kΩ				
<b>External Modulation Input</b>					
For AM, FM, PM, SUM and PWM					
Voltage Range:	± 2.5V full scale				
Input Impedance:	5kΩ typical				
Bandwidth:	DC to 5MHz				
<b>Ref Clock / Count (AC) Input</b>					
Input for an external 10MHz reference clock and AC coupled external frequency measurement.					
Voltage Range:	<table border="1"> <tr> <td>≤50MHz</td> <td>100mVpp – 5Vpp</td> </tr> <tr> <td>&gt;50MHz</td> <td>250mVpp – 5Vpp</td> </tr> </table>	≤50MHz	100mVpp – 5Vpp	>50MHz	250mVpp – 5Vpp
≤50MHz	100mVpp – 5Vpp				
>50MHz	250mVpp – 5Vpp				
Maximum Voltage:	+10V				
Minimum Voltage:	-10V				

Interfaces	
Full digital remote control facilities are available through LAN, USB and optional GPIB interfaces.	
LAN Interface	Ethernet 100/10base – T hardware connection. 1.5 LXI Device Specification 2016
USB Interface	Standard USB 2.0 hardware connection. Implemented as virtual-COM port.
USB Flash Drive	For waveform and set-up storage/recall.
GPIB (optional)	Conforming with IEEE488.1 and IEEE488.2

General	
Display:	4.3 inch (10.9 cm) transfective backlit TFT LCD, 480 x 272 pixels, 262144 colours, adjustable brightness and contrast.
Data Entry:	Keyboard selection of mode, waveform etc.; value entry direct by numeric keys or by rotary control.
Stored Settings:	Up to 9 complete instrument set-ups may be stored and recalled from internal memory.
Size:	Bench Top: 97mm height; 250mm width; 295mm depth Rack mount: 86.5mm (2U) height; 213.5mm (½-rack) width; 269mm depth
Weight:	3.2kg
Power:	100-240VAC ±10% 50/60Hz ; 100-120VAC ±10% 400Hz ; 60VA max. Installation Category II.
Operating Range:	+5°C to 40°C, 20–80% RH.
Storage Range:	–20°C to + 60°C.
Environmental:	Indoor use at altitudes up to 2000m, Pollution Degree 2.
Options:	19 inch rack mounting kit.
Safety & EMC:	Complies with EN61010–1 & EN61326-1. For details, request the EU Declaration of Conformity for this instrument via <a href="http://www.aimtti.com/support">http://www.aimtti.com/support</a> (serial no. needed).

For details, request the EU Declaration of Conformity for this instrument via <http://www.aimtti.com/support> (serial no. needed).

General specifications apply for the temperature range 5°C to 40°C.

Accuracy specifications apply for the temperature range 18°C to 28°C after 30 minutes warm-up, at maximum output into 50Ω.

Typical specifications are determined by design and are not guaranteed.

## EXCELLENCE THROUGH EXPERIENCE

Aim-TTi is the trading name of Thurlby Thandar Instruments Ltd. (TTi), one of Europe's leading manufacturers of test and measurement instruments.

The company has wide experience in the design and manufacture of advanced test instruments and power supplies built up over more than thirty years.

The company is based in the United Kingdom, and all products are built at the main facility in Huntingdon, close to the famous university city of Cambridge.

## TRACEABLE QUALITY SYSTEMS

TTi is an ISO9001 registered company operating fully traceable quality systems for all processes from design through to final calibration.



ISO9001:2015

Certificate number FM 20695

## WHERE TO BUY AIM-TTI PRODUCTS

Aim-TTi products are widely available from a network of distributors and agents in more than sixty countries across the world.

To find your local distributor, please visit our website which provides full contact details.



Designed and built in Europe by:



**Thurlby Thandar Instruments Ltd.**

Glebe Road, Huntingdon, Cambridgeshire.

PE29 7DR United Kingdom

Tel: +44 (0)1480 412451 Fax: +44 (0)1480 450409

Email: sales@aimtti.com Web: www.aimtti.com



4 8 5 9 1 - 1 4 2 0 0 1