



SMART DISCHARGER
FD-100 80W



FD-100

User manual Ver 1.1.112

Disclaimer and Warning

Thank you for using the product from SHENZHEN ISD TECHNOLOGY CO.,LTD

This product is specifically designed for RC, not appliance in other areas. We strongly recommend you read our user's guide before using FD-100. ISDT accepts no liability for damage, injury or any legal responsibility incurred directly or indirectly from the use of this product.

ISDT reserves the right to update the design, appearance, function and usage requirement without notifying.

10.20,2017

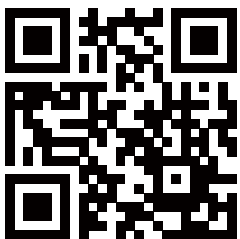

Revolution Starts Here

www.isdt.co

Product Info

Max Discharging Power	80W
Min input voltage	6V
Max input voltage	35V
Support battery cells	2-8S
Support battery type	LiPo, LiHv, LiFe, Lilon
Self power off protection	support
Wrong voltage alarm	support
Wrong cell setting alarm	support
Beeper	80dB
Weight	295g

Function Button

1. Cells selection button
2. Current selection button
3. Working status light
4. Battery input port
5. PC port
6. Beeper

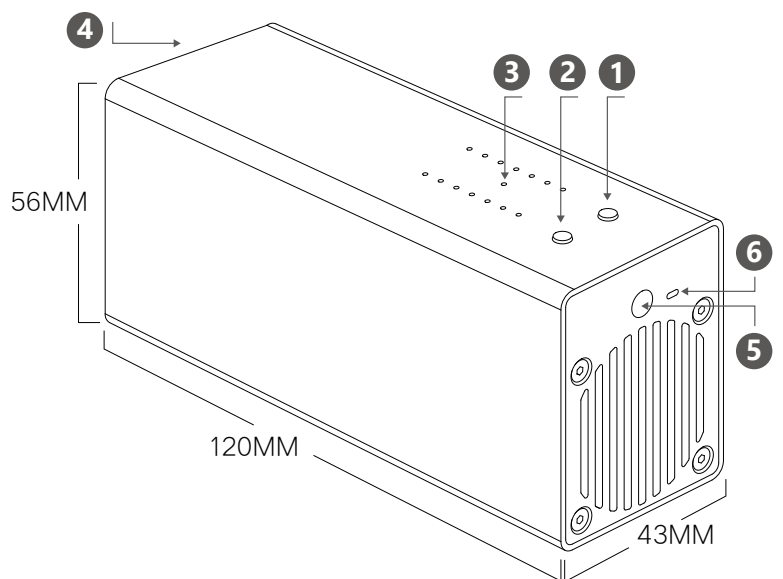

Operation Guide

1. Plug in battery, select cells button

2. Make sure selected number of cells is correct

(For wrong number of cell selection, red light will blink, beeper alarm for 60 second, then auto power off)

3. After 5 second, FD100 would start working, green light will blink.

4. When battery voltage reaches cut off voltage, green light will be always on, beeper alarm for 60s, then auto power off.

(Default discharging voltage is 3.80v /cell, voltage could be modified through PC software, ISDT Q6 pro, T8 smart charger. Adjustable range 3.3v-4.0v/cell)

Safety Precautions:



WARNING!



FIRE HAZARD!

Before connecting battery, make sure your battery voltage is within working voltage of FD100.

During operation, make sure number of cells is correct

- Failure to observe safety procedures may cause damages to property or injury.
- Only operate this product in a cool ventilated area away from flammable objects.
- This unit will generate a lot of heat during usage, make sure air is floating,
- avoid any physical contact to the metal part of this unit during usage.

PC Operation Guide

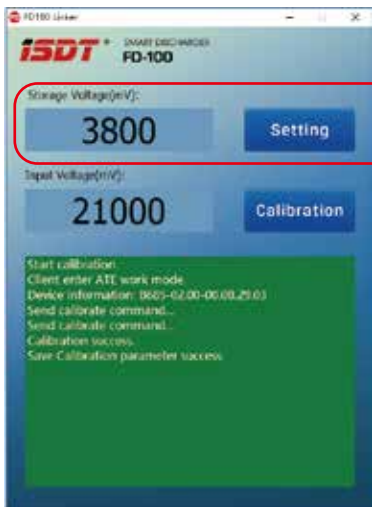
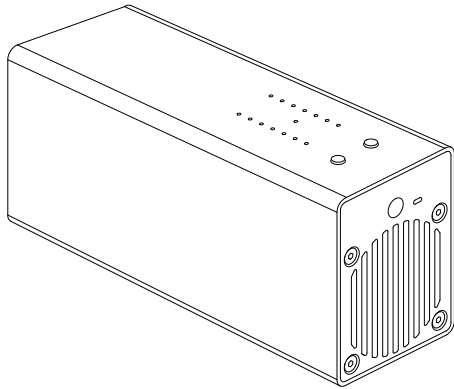

A Discharge cut-off voltage setting:

- 1, Connect the FD-100 and PC with a scLinker
- 2, Please make sure the battery is within allowed range first, then choose the series to get the FD-100 start work.
- 3, Use the "FD-100 linker.exe" to set the storage voltage (3.3V-4.0V/-cell). When the background color turns green, the setting was successful.

PC Operation Guide

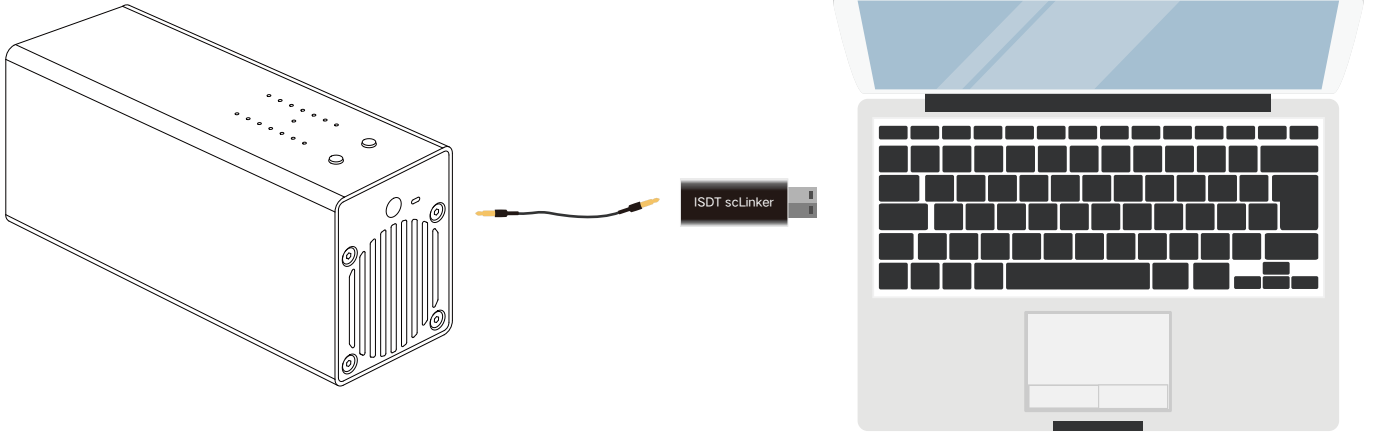

B FD-100 voltage calibration :

- 1, Connect the FD-100 and PC with a scLinker
- 2, Please make sure the battery is within allowed range first, then measure the battery's real voltage and take a note.
- 3, Use the "FD-100 linker.exe" to fill in the real voltage (measured on step 1), and then click "Calibration(F8)" button. When the background color turns green, the calibration was successful.

* You could use ISDT BG-8S/BC-8S/Smart Charge to measure the battery's real voltage. Please make sure the balance port was connected when you use a smart charger. Or you could also use a multimeter to measure the voltage.

* In order to ensure proper functioning of FD-100, please repower after calibration.



WWW.ISDT.CO

Shenzhen ISD Technology CO.,LTD

Address: 5th Fl., Bldg. 9, Mabian Industrial Zone, Yangtian Rd.,
Block 72, Xin'An Street, Bao'An District, Shenzhen, PRC

Email: hi@isdt.co

Changes in specifications and data will not be further noticed.