

Type MJS

Lightning Surge Withstand Fuse

HF  MJS Series, 5x15mm Glass Tube Lightning Surge Withstand Fuse RoHS 2 Compliant

Description

MJS fuses have been used for Tip and Ring protection in telecommunication circuits. And they continue to be used in legacy designs. However, with advent of new issues of IEC/UL 60950 and Telcordia GR-1089(Issue 3). MJS fuses may no longer meet all test requirements, depending on the end product circuit design. It is recommended that Types RJS and SMP be evaluated for all new telecommunication applications.



Features

- Meet UL and CSA standard 248-14
- Wide operating temperature range
- Bulk and Tape & Reel packing available
- RoHS 2 compliant
- Halogen Free
- Leadfree

Applications

Provide individual protection for components or internal circuits.

- Power supplies
- Battery charger
- Monitor
- Adapter
- Telecom protection

LEAD FREE = 
 HALOGEN FREE = 





Physical Specifications

| | |
|-----------|---|
| Materials | Body : Glass |
| | Cap : Nickel Plated Brass Caps |
| | Leads : Matte Tin Plated Copper, Diameter 0.032" |
| Marking | On Fuse : |
| | "bel", "MJS", "Current Rating", "Voltage Rating", "Appropriate Safety Logos", "✓" (RoHS 2 compliant) |
| | On Label : |
| | "bel", "MJS", "Current Rating", "Voltage Rating", "Interrupting Rating", "Appropriate Safety Logos" and "✓", "  " (China RoHS compliant). |

Electrical Characteristics (UL/CSA STD.248-14)

| Testing Current | Blow Time | |
|-----------------|-----------|----------|
| | Minimum | Maximum |
| 100% | 4 hrs. | N/A |
| 135% | N/A | 1 Hr. |
| 200% | 3 sec | 20 sec |
| 500% | 100 msec | 1.5 sec |
| 1000% | 30 msec | 300 msec |

Safety Agency Approvals

| Safety Agency | Safety Agency Certificate | Voltage Rating (V) | Ampere Range / Volt @ I.R. ability* |
|---|---------------------------|----------------------|-------------------------------------|
|  | E20624 | 100mA-7A/ 250V AC | 100mA-7A/125V AC@10,000A |
|  | LR39772 | | 100mA-7A/250V AC@200A |
|  | JET1037-31003-1011 | | 1A-5A/125V AC@500A |

*I.R.= Interrupting Rating = Short Circuit Rating(Amps)

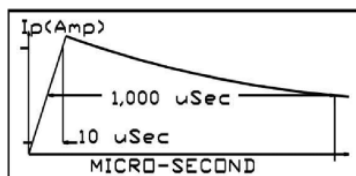

FIG A

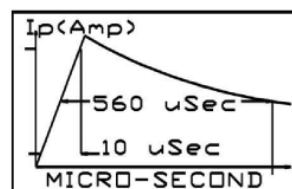





FIG B

Environmental Specifications

| | |
|---------------------------|--|
| Shock Resistance | MIL-STD-202G, Method 213B, Test Condition 1 (100 G's peak for 6 milliseconds; Sawtooth waveform) |
| Vibration Resistance | MIL-STD-202G, Method 201A (10-55 Hz, 0.06 inch, total excursion). |
| Salt Spray Resistance | MIL-STD-202G, Method 101E, Test Condition B (48 hrs.). |
| Insulation Resistance | MIL-STD-202G, Method 302, Test Condition A (After Opening) 10,000 ohms minimum. |
| Solderability | MIL-STD-202G, Method 208H |
| Resistance to solder Heat | MIL-STD-202G, Method 210F, Test Condition B (260+/-5°C, 10+/-1 sec) |
| Thermal Shock | MIL-STD-202G, Method 107G, Test Condition B (-65°C to +125°C). |
| Operating Temperature | -55°C to +125°C |
| Terminal Strength | IEC-68-2-21 |

Electrical Specifications

| Catalog Number | Ampere Rating | Typical Cold Resistance (ohm) | Volt-drop @100%In (Volt) max. | Voltage and Interrupting Ratings | Melting I ² T <10 mSec (A ² Sec) | Melting I ² T @10 In (A ² Sec) | Peak Surge Current (Amp) | | Maximum Power Dissipation (W) | Agency Approvals | | |
|----------------|---------------|-------------------------------|-------------------------------|---|--|--|---------------------------------|--------------------------------|-------------------------------|---|---|---|
| | | | | | | | (Fig A) 25 Pulses 10uS x 1000uS | (Fig B) 50 Pulses 10uS x 560uS | |  |  |  |
| MJS 100-R | 100mA | 12.5 | 1.88 | See Table of Safety Approvals on Page 1 for Voltage and associated Interrupting Ratings | 0.068 | 0.088 | 4.5 | 6.0 | 0.22 | Y | Y | |
| MJS 125-R | 125mA | 7.8 | 1.44 | | 0.107 | 0.138 | 5.6 | 7.5 | 0.24 | Y | Y | |
| MJS 150-R | 150mA | 5.3 | 1.17 | | 0.167 | 0.216 | 6.8 | 9 | 0.27 | Y | Y | |
| MJS 200-R | 200mA | 3.7 | 1.02 | | 0.26 | 0.34 | 9 | 12 | 0.30 | Y | Y | |
| MJS 250-R | 250mA | 2.27 | 0.89 | | 0.41 | 0.53 | 12 | 16 | 0.34 | Y | Y | |
| MJS 300-R | 300mA | 1.57 | 0.78 | | 0.60 | 0.83 | 15 | 17 | 0.36 | Y | Y | |
| MJS 350-R | 350mA | 1.10 | 0.72 | | 0.8 | 1.0 | 18 | 24 | 0.40 | Y | Y | |
| MJS 400-R | 400mA | 0.875 | 0.67 | | 1.0 | 1.3 | 20 | 27 | 0.42 | Y | Y | |
| MJS 500-R | 500mA | 0.630 | 0.59 | | 1.6 | 2.0 | 26 | 35 | 0.47 | Y | Y | |
| MJS 600-R | 600mA | 0.440 | 0.53 | | 2.2 | 2.3 | 29 | 33 | 0.49 | Y | Y | |
| MJS 700-R | 700mA | 0.341 | 0.49 | | 3.0 | 4.0 | 38 | 50 | 0.54 | Y | Y | |
| MJS 750-R | 750mA | 0.326 | 0.48 | | 3.0 | 4.0 | 38 | 50 | 0.55 | Y | Y | |
| MJS 800-R | 800mA | 0.250 | 0.42 | | 5.0 | 7.0 | 50 | 66 | 0.60 | Y | Y | |
| MJS 1-R | 1A | 0.195 | 0.39 | | 5.9 | 7.8 | 56 | 75 | 0.64 | Y | Y | Y |
| MJS 1.25-R | 1.25A | 0.130 | 0.34 | | 9.3 | 12 | 75 | 100 | 0.71 | Y | Y | Y |
| MJS 1.5-R | 1.5A | 0.100 | 0.29 | | 15 | 19 | 94 | 125 | 0.80 | Y | Y | Y |
| MJS 2-R | 2A | 0.061 | 0.26 | | 23 | 30 | 120 | 160 | 0.89 | Y | Y | Y |
| MJS 2.5-R | 2.5A | 0.046 | 0.22 | | 35 | 47 | 150 | 200 | 0.99 | Y | Y | Y |
| MJS 3-R | 3A | 0.037 | 0.19 | | 55 | 73 | 195 | 260 | 1.10 | Y | Y | Y |
| MJS 3.5-R | 3.5A | 0.029 | 0.18 | | 69 | 91 | 225 | 300 | 1.16 | Y | Y | Y |
| MJS 4-R | 4A | 0.024 | 0.17 | | 86 | 114 | 255 | 340 | 1.22 | Y | Y | Y |
| MJS 5-R | 5A | 0.019 | 0.15 | | 135 | 179 | 330 | 440 | 1.36 | Y | Y | Y |
| MJS 6-R | 6A | 0.015 | 0.13 | | 211 | 279 | 428 | 570 | 1.51 | Y | Y | |
| MJS 7-R | 7A | 0.012 | 0.12 | | 263 | 350 | 488 | 650 | 1.60 | Y | Y | |

Consult manufacturer for other ratings



Specifications subject to change without notice

Bel Fuse Inc.
206 Van Vorst Street
Jersey City, NJ 07302 USA

+1 201.432.0463
Bel.US.CS@belf.com
belfuse.com/circuit-protection

Temperature Derating Curve

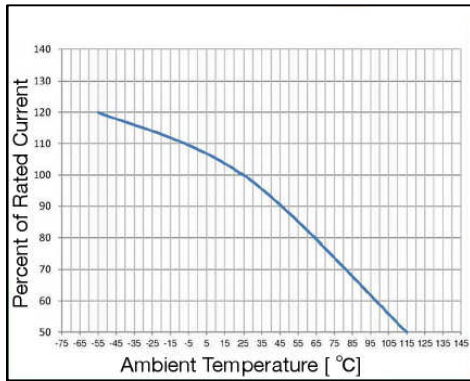

Average Time Current Curve

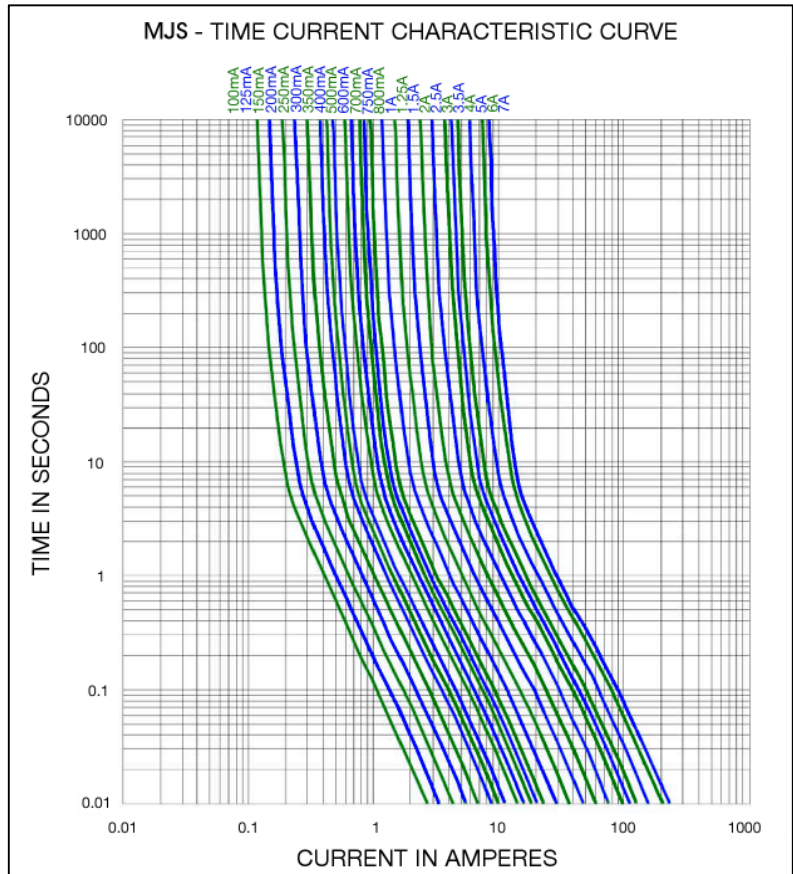

Soldering parameters

| Lead-free Wave Soldering Profile | |
|--|--|
| Wave Soldering Parameter | |
| Average ramp-up rate | 200°C / second |
| Heating rate during preheat | typical 1 - 2°C / second Max 4°C / second |
| Final preheat temperature | within 125°C of soldering temperature |
| Peak temperature T _p | 260°C |
| Time within +0°C / -5°C of actual peak temperature | 10 seconds |
| Ramp-down rate | 5°C / second max. |

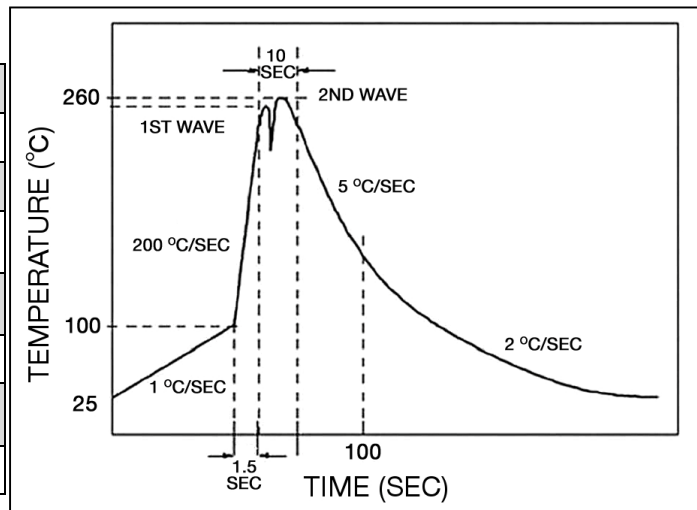

Fuse FGNO Explanation

0653 R [XXXX] -XX

0653R=MJS; [XXXX]=Ampere Rating; XX=See Ordering Information as below

| Fraction | Decimal | Milliamps | Bel FGNO[XXXX] |
|----------|---------|-----------|----------------|
| 1/10 | 0.100 | 100 | 0100 |
| 1/8 | .125 | 125 | 0125 |
| 15/100 | .150 | 150 | 0150 |
| 2/10 | .200 | 200 | 0200 |
| 1/4 | .250 | 250 | 0250 |
| 3/10 | .300 | 300 | 0300 |
| 35/100 | .350 | 350 | 0350 |
| 4/10 | .400 | 400 | 0400 |
| 1/2 | .500 | 500 | 0500 |
| 6/10 | .600 | 600 | 0600 |
| 7/10 | .700 | 700 | 0700 |
| 3/4 | .750 | 750 | 0750 |
| 8/10 | .800 | 800 | 0800 |

| Fraction | Decimal | Amps | Bel FGNO[XXXX] |
|----------|---------|------|----------------|
| | 1.0 | 1 | 1000 |
| 1-1/4 | 1.25 | 1.25 | 1250 |
| 1-1/2 | 1.50 | 1.5 | 1500 |
| | 2.0 | 2 | 2000 |
| 2-1/2 | 2.5 | 2.5 | 2500 |
| | 3.0 | 3 | 3000 |
| 3-1/2 | 3.5 | 3.5 | 3500 |
| | 4.0 | 4 | 4000 |
| | 5.0 | 5 | 5000 |
| | 6.0 | 6 | 6000 |
| | 7.0 | 7 | 7000 |
| | | | |
| | | | |

Mechanical Dimensions

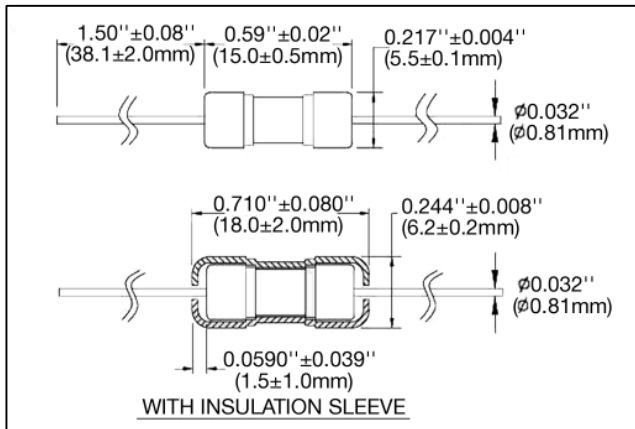

*Diameter lead 0.032" for all ratings

Ordering Information

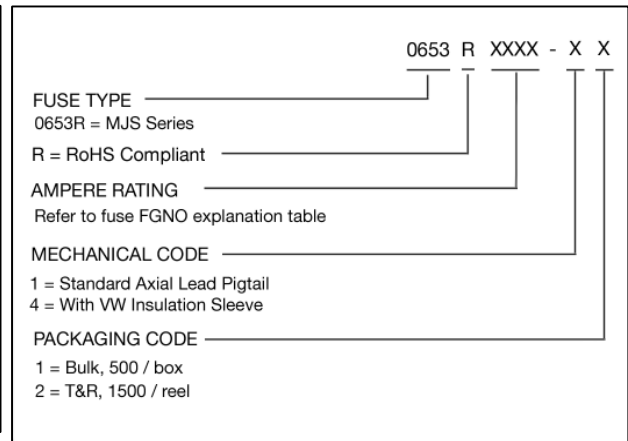

Packaging

| Packaging Option | Packaging Specification | Quantity | Packaging Code | Inside Tape Spacing |
|--|-------------------------|----------|----------------|---------------------|
| Bulk (Pigtail Type) | N/A | 500 | 11 | N/A |
| Bulk (Pigtail Type) with Insulation Sleeve | N/A | 500 | 41 | N/A |
| Tape & Reel, 10mm Pitch | EIA-296-F | 1500 | 12 | 53 |
| Tape& Reel with Insulation Sleeve, 10 mm Pitch | EIA-296-F | 1500 | 42 | 53 |



Specifications subject to change without notice

Bel Fuse Inc.
 206 Van Vorst Street
 Jersey City, NJ 07302 USA

+1 201.432.0463
 Bel.US.CS@belf.com
belfuse.com/circuit-protection