

SPECIFICATION FOR APPROVAL

CUSTOMER : _____

CUSTOMER PART NO. : _____

CUSTOMER APPROVED	APPROVED BY	CHECKED BY	PREPARED BY
		 	

MODEL NO. : AD1224UB-F5B(N21Q)

DESCRIPTION : IP55

SPEC NO. : SA-0120170410005

ISSUE DATE : 2017.04.11

REVISION : A00

THIS OFFER IS MADE ACCORDING TO YOUR CURRENT INQUIRY.
UNLESS OTHERWISE REVISED, THIS SPECIFICATION WILL BE FINAL FOR
ALL FUTURE PRODUCTION OF ORDERS FROM YOUR RESPECTED COMPANY

KINDLY STUDY IN DETAILS AND RETURN TO US THE DUPLICATE DULY
SIGNED AS YOUR CONFIRMATION OF SAME.



ADDACORPORATION

BRUSHLESS AXIAL COOLING FANS

Customer	:		Ref: (RoHS)
Adda Model No	:	AD1224UB-F5B(N21Q)	
Samples attached	:	Piece(s),	
Safety Approval	:	CE	CE:EN 61000-6-1:2007 EN 61000-6-3:2007+A1
Specifications			
<u>ITEM</u>	<u>SPECIFICATION / CONDITION</u>		
DIMENSIONS	:	120x120x38	mm
BEARING TYPE	:	TWO BALL	
RATED VOLTAGE	:	24	VDC
OPERATING VOLTAGE RANGE	:	21.6	VDC — 26.4 VDC
START-UP VOLTAGE	:	17.0	VDC , NORMAL
REAL CURRENT	:	0.38	Amp
REAL POWER	:	9.12	Watt
RATED CURRENT	:	0.40	Amp + 10 %MAX
RATED POWER	:	9.60	Watt
RATED SPEED	:	3200	RPM ± 10 % (IN FREE AIR AT RATED VOLTAGE)
AIR FLOW	:	114.361	CFM (min.: 102.924 CFM)
AIR FLOW	:	3.236	CMM (min.: 2.912 CMM) (IN FREE AIR AT RATED VOLTAGE)
STATIC AIR PRESSURE	:	0.349	Inch H ₂ O (min.: 0.282 Inch H ₂ O)
STATIC AIR PRESSURE	:	8.864	mm H ₂ O (min.: 7.179 mm H ₂ O) (IN FREE AIR AT RATED VOLTAGE)
NOISE LEVEL	:	52.6	dB (A) (max.: 56.6 dB(A))
MOTOR PROTECTION	:	BY	IC
POLARITY PROTECTION	:	YES	
CONNECTION LEAD TYPE	:	WIRE, AWG#	24
LIFE EXPECTANCY	:	70000	Hours at 40°C / 65%
NET WEIGHT	:	297	Gram.
PACKING	:	40	pcs. Per Export Carton.
<p>* If no PWM signal is present (no connection to the PWM drive signal) then the fan should run at maximum RPM.</p> <p>* The fan must start spinning with a 30% duty cycle or less.</p> <p>Unless otherwise stated, the relative humidity is 65%, and the temperature is 25°C for the standard testing.</p> <p>Should you have any doubt, please refer to the environmental conditions specified in the acknowledgement document.</p>			
			
ADDA CORPORATION	Model No.:	AD1224UB-F5B(N21Q)	Page 1/6

SPECIFICATION

1.0 SCOPE

This documentation defines the mechanical & electrical Characteristics of DC Brushless Fans.

2.0 MATERIAL

- 2.1 Impeller : UL94V-0 Glass Filled polyester (P.B.T)
- 2.2 Frame : Aluminum alloy
- 2.3 RoHS : (V) YES
- HF : () YES

3.0 DIMENSIONS & CONSTRUCTION

All dimensions, Direction of rotation and air flow were specified as per drawing attached.

4.0 CHARACTERISTICS & DEFINITION

- 4.1 All rated characteristics were specified as per data sheet enclosed.
- 4.2 Rated Current : Rated Current shall be measured after 3 minutes of continuous rotation at rated voltage.
- 4.3 Rated Speed : Rated Speed shall be measured after 3 minutes of continuous rotation at rated voltage.
- 4.4 Start Voltage : The voltage which is able to start the fan to operate by suddenly switching ' ON ' .
- 4.5 Input Power : Input Power shall be measured after 3 minutes of continuous rotation at rated voltage.
- 4.6 Locked Rotor Current : Locked current shall be measured within one minute of rotor locked, after 3 minutes of continuous rotation at rated voltage in clean air.
- 4.7 Air Flow & Static Pressure : The air flow data and static pressures should be determined in accordance with AMCA-210 standard in a doublechamber testing with intake – side measurement.
- 4.8 Noise Level : The measurement of noise level is carried out with reference to ISO7779 in a semi-anechoic chamber with the microphone positioned 1 meter from the air intake. Testing fan shall be hung in clean air .

NOISE LEVEL MEASUREMENT

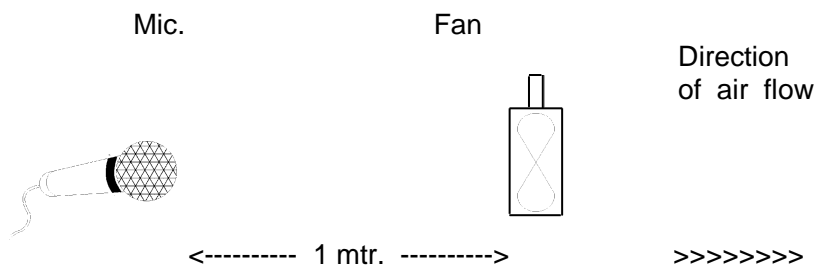

- 4.9 Protection Degree : IP 55 in accordance to IEC60529 standard



SPECIFICATION

5.0 MECHANICAL INSPECTION

5.1 Rotation Direction

Counterclockwise when look into impeller side.

5.2 Protection

All fans have integrated protection against locked rotor condition so that there will be no damage to winding or any electronic component.

Restarting is automatic as soon as any constraint to rotation has been released.

As fan placed at dead angle position, and the switch was changed from off to on. Restarting was automatic normal as soon as and proved that this fan is good fan.

5.3 Locked Rotor Protection

No damage shall be found after 72 hours continuously at condition of rotation locked.

Restarting is automatic as soon as constraint to running has been released.

5.4 Avoid the damage, check the correct voltage and proper polarity before connecting with power.

5.5 Free Drop Shock

In minimum package condition, the fan should withstand drops on any three faces from a height of 30cm onto a wood board of 10mm thick.

5.6 Please do not stick a grease and/or an oil to the fan housing or blade which may have a harmful influence by a chemical reaction at high humidity.

6.0 ELECTRICAL INSPECTION

6.1 Insulation Resistance

Not less than 10M ohm between housing and positive end of lead wire (red) at 500V DC.

6.2 Dielectric Strength

No damage should be found at 500 VAC for 60 seconds, measured with 1mA trip current between housing and positive end of lead wire.

6.3 Life Expectancy

The continuous duty life at given temperature after which, 90% of testing units shall still be running.

7.0 ENVIRONMENTAL

7.1 Operating Temperature / Humidity

-10°C to +70°C at humidity 100% RH.

7.2 Storage Temperature

All function shall be normal after 500 hours storage at -40°C to +70 °C with a 24 hour recovery period at room temperature.

7.3 Humidity

After 96 hours, 95% RH, 40+/-2°C per MIL-STD-202F, method 103B humidity test, the measured data on insulation resistance and dielectric strength shall meet the specification.



SPECIFICATION

8.0 REMARKS

- 8.1 Material and construction are subject to change without advance notice. The changes should be within specification.
- 8.2 All fans shall meet the quality inspection under sampling plan MIL-STD-105E as follow:

Critical	0.25%
Major	1.00%
Minor	2.50%

9.0 OUTLINE STYLING & DIMENSIONS

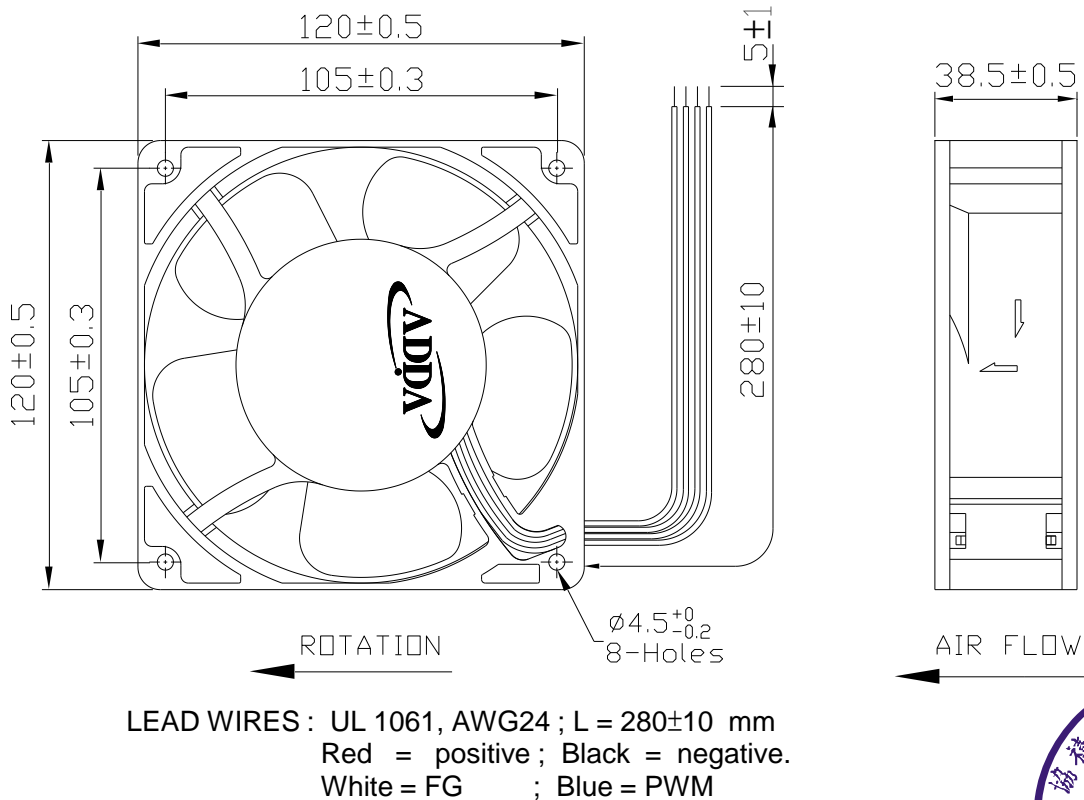

10.0 Notes:

- 10.1 Please do not touch and push Fan Blade with fingers or others, fan blade and ball bearings may be damaged and it causes noise defect.
- 10.2 Do not carry the fan by its lead wires.
- 10.3 If the fan does not have the polarity protection function, the connection of the colored wires should be red + red, and black + black, or else the fan will be damaged in no time.
- 10.4 For the models without reverse connection of polarity protection, please do not connect the lead wire in reverse
- 10.5 Please don't install this fan in series with 2x voltage inputs. For example, if a single fan rated at 12V, then don't install two of them in series with 24V input.
- 10.6 Every specific fan is designed for its certain application (project). Therefore, if you want to use this fan in other application (project), please inform ADDA first so that we can confirm whether there is any issue which might be incurred from the reason of this different application (project) or not.
- 10.7 The "Life Expectancy" of this fan has not been evaluated for use in combination with any end application. Therefore, the Life Expectancy in the Test Reports (L10 and MTTF Report) that relate to this fan is for reference only and shall not construe any kind of warranty of ADDA to the life of any specific fan, either expressed or implied.
- 10.8 The period of product warranty, unless otherwise agreed by ADDA in written, shall be 12 months starting from the date of production.
- 10.9 In Lead Wire, there is a possibility to come off from frame.





PROVISION OF DIGITAL PWM SPEED CONTROL & LOCKED SIGNAL(F.G)

- OUTPUT OF LOCKED SIGNAL -----OPEN DRAIN TYPE

*Electrical design suggestion:R=3K~10K

(External signal function design is decided by customer)

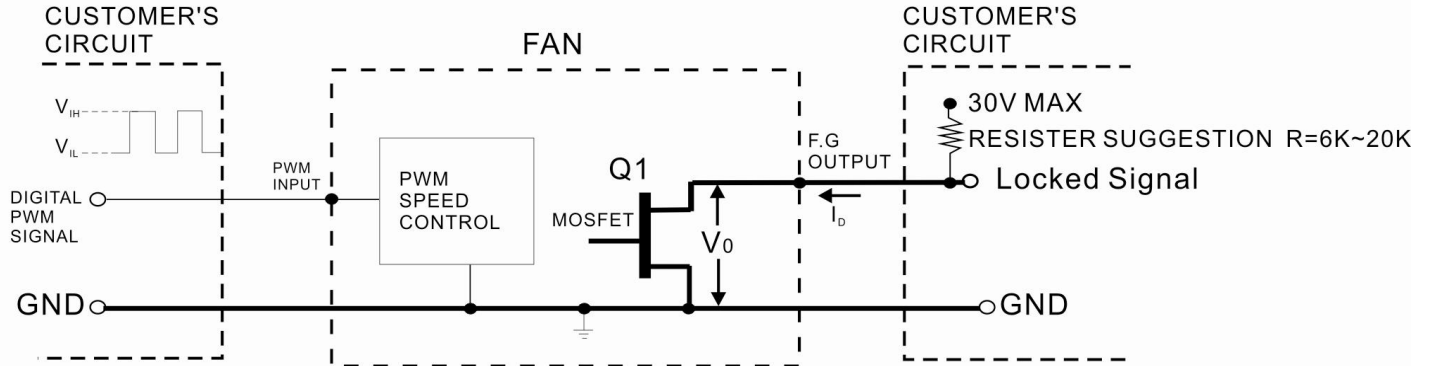

*MOSFET Q1 AT "ON" POSITION

DRAIN CURRENT----- $I_D=5mA$ MAX

SATURATION VOLTAGE----- $V_{OL}=1.0V$ MAX

*MOSFET Q1 AT "OFF" POSITION

RELEASE VOLTAGE----- $V_{OH}=30V$ MAX

*DIGITAL PWM SPEED CONTROL POSITION

PWM INPUT VOLTAGE HIGH----- $V_{IH}=3.0V\sim 5.5V$

PWM INPUT VOLTAGE LOW----- $V_{IL}=0V\sim 0.5V$

*PWM INPUT FREQUENCY-----FPWM:18~30KHZ

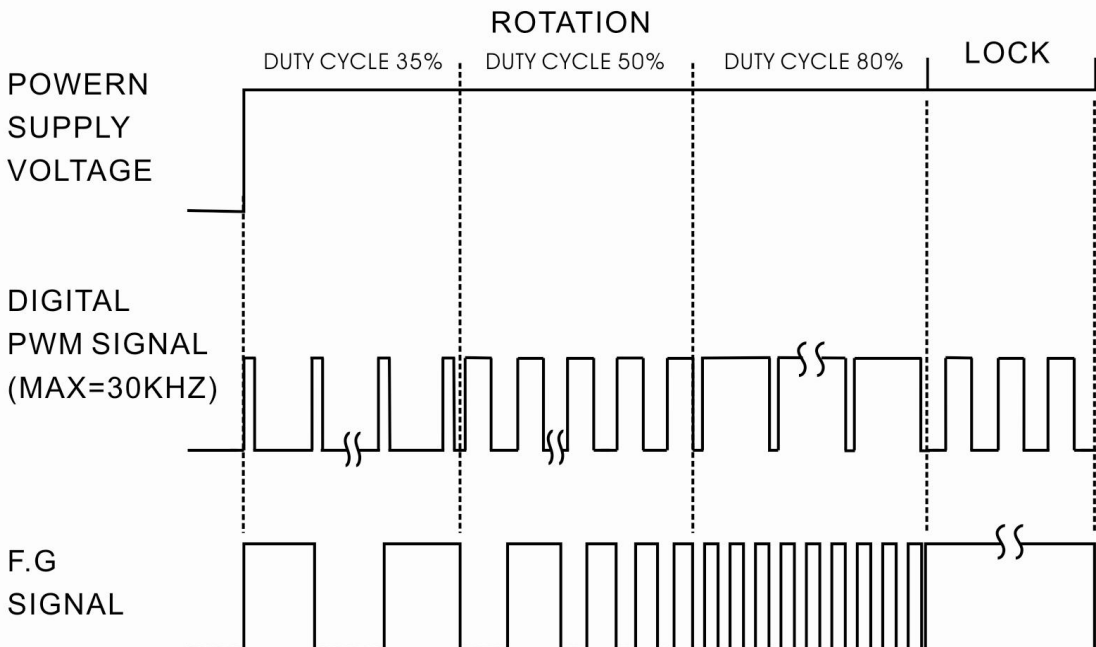

Fan Performance Curve

FLOWRATE(CMM)

