



Model Number

AS 12/60

Stop screw for series F2 sensors

Features

- Safely sets the mechanical end stop position

Technical Data

Mechanical specifications

Operating force	min. 3 N max. 20500 N
Material	Steel 1.1191 / AISI 1045 (C45)
Dimensions	
A	M12 x 1
B	3 mm
C	8.8 mm
L	56 mm
L1	73.7 mm
L2	71.8 mm
L3	69.5 mm
Tightening torque	max. 26 Nm

General information

Note	If necessary, properly secure the lock nut
Scope of delivery	Stop screw Counter nut

Dimensions

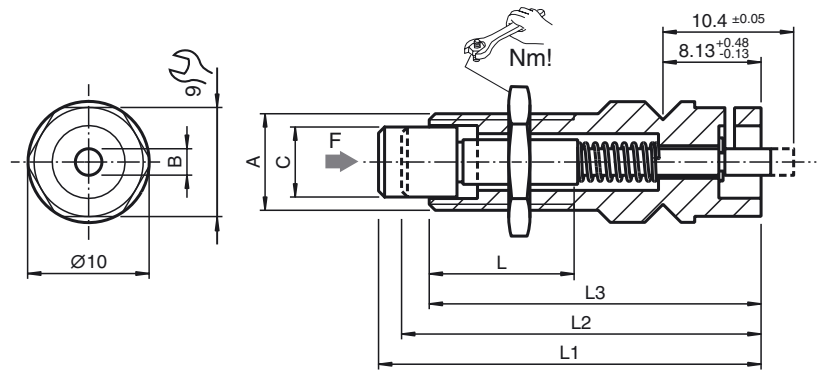

Release date: 2015-02-02 16:35 Date of issue: 2015-02-02 189992_eng.xml